

# GREEN PIN<sup>®</sup>

# PRODUCT CATALOGUE

METRIC



# KEY ICONS

## Certificates

Depending on the type of product and certificate availability for a certain product, the below mentioned certificates are used in this catalogue. For more information see page 15.

Type 2.1	Works certificate to EN 10204	2.1
Type 2.2	Works certificate to EN 10204	2.2
Type 3.1	Inspection certificate to EN 10204	3.1
Type MTC a	Manufacturer test certificate	MTC <sup>a</sup>
Type MTC b	Manufacturer test certificate	MTC <sup>b</sup>
Type LROS	Proofload Statement	LROS
Type MPI a	Non-destructive testing report	MPI <sup>a</sup>
Type MPI b	Non-destructive testing report	MPI <sup>b</sup>
Type US a	Non-destructive testing report	US <sup>a</sup>
Type US b	Non-destructive testing report	US <sup>b</sup>
Type DNV 2.7-1 a	Type Approval certificate to DNV - ST - E271/E273	DNV 2.7-1 <sup>a</sup>
Type DNV 2.7-1 b	Type Approval certificate to DNV - ST - E271/E273	DNV 2.7-1 <sup>b</sup>
Type DNV CG3	Certificate Proof load witnessed and issued by DNV	DNV CG3
Type DNV 0377	Type Approval certificate to DNV - ST 0377 (former DNV 2.22)	DNV 0377
Type DNV 0378	Type Approval certificate to DNV - ST 0378 (former DNV 2.22)	DNV 0378
Type NYTEK / NS 9415	Type Approval certificate to NYTEK-regulation and NS 9415	DNV NS 9415
Type DGUV	DGUV Type approval certificate to EN 1677	DGUV
Type CE IIA	CE declaration of conformity	CE IIA
Type CE IIB	CE declaration of incorporation	CE IIB
Type BL	Break Load test certificate	BL
Type ABS PDA	Certificate of Product Design Assessment Approval	ABS PDA
Type ABS MA	Certificate of Manufacturing Assessment Approval	ABS MA

### Conditions

Certificate types 2.1, 2.2, 3.1, MTC a, DNV 2.7-1 a, DNV 2.7-1 b, DNV 0377, DNV 0378, DGUV, ABS PDA, ABS MA and CE can be supplied at no extra charge. For all other certificates, additional costs will be charged.

## Other

RFID Tag	RFID
CAD drawings	CAD
More info	INFO
Complementary product	C

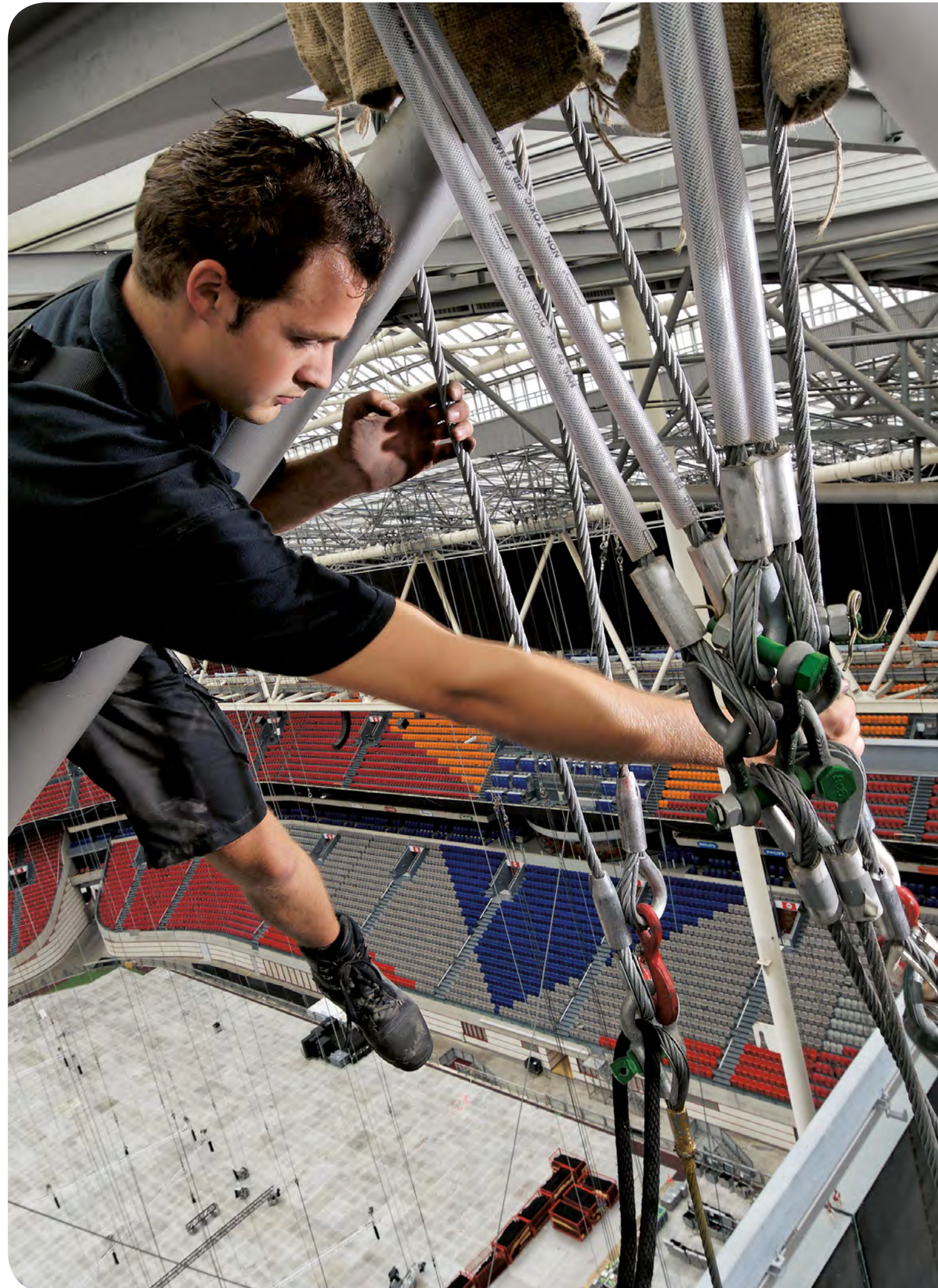



**Introduction** **4**

**3 Lifting Sling Fittings** **78** **3**

3.1 For wire rope **82** **3.1**

3.2 For Grade 8 chain **144** **3.2**

3.3 For Grade 10 chain **174** **3.3**

3.4 For Green Pin Tycan® chain **200** **3.4**

3.5 For synthetic slings **224** **3.5**

# WELCOME TO THE WORLD OF GREEN PIN®



# THE CENTREPIECE OF RIGGING

Welcome to the world of Green Pin<sup>®</sup>, the leading brand for premium quality lifting and lashing equipment. Leading, but modest. We know our role, the place of our Green Pin<sup>®</sup> products in your bigger picture. And that is right in the centre of your rigging. The centre of safety. The centre of reliability. And the centre of responsibility. Because we know that Green Pin<sup>®</sup> products are often part of extremely large and complex projects.

Being part of project that come with great risks and great interests to people and products at the same time, great responsibility is required. Taking that responsibility is key to Green Pin<sup>®</sup>. We want to reassure our customers by always providing products of the highest quality, as we have done for over a hundred years. Our quality is always 100%, but guaranteeing a 99% availability of our products is just as essential to us.

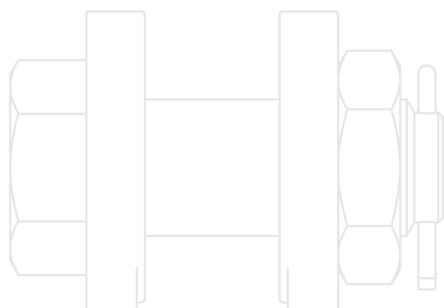

# ALWAYS IN THE CENTRE OF RIGGING

Green Pin® combines innovative, high-quality products with the quickest delivery and the best customer support. The best lifting and lashing equipment developed with a clear vision of what you need. Produced with raw materials from trustworthy suppliers, at our state-of-the-art production facilities. Facilities that produce products with minimal margins of error compared to other production methods. These Green Pin® products are available all over the world by one of our 900 distributors. We make sure that we are always ready to meet the demands of the most complex lifting projects in the world.



**OVER 1000 DISTRIBUTORS IN  
MORE THAN 100 COUNTRIES  
STOCK GREEN PIN® PRODUCTS**

# RELY ON THE BEST EQUIPMENT AND SUPPORT. GUARANTEED

The core, of the Green Pin® brand is quality. Green Pin® products are better designed, developed, engineered, produced, packed, delivered, and serviced. When it comes to quality, Green Pin® will not settle for less than best in breed. So, all our raw materials come from highest qualified suppliers who guarantee full traceability. Our steel is sourced from leading, fully certified European mills. Green Pin® is all about quality. That quality is the centrepiece of our brand, and our promise to you is we will never let you down. You can trust us to be the centrepiece of your rigging.

## YOU GET THE BEST

- ⊕ CAD-drawings and technical documentation that are distinguishing by their accuracy;
- ⊕ A technical helpdesk that provides comprehensive answers swiftly;
- ⊕ Technical training to provide insights into the benefits of our products and the different ways to apply them.

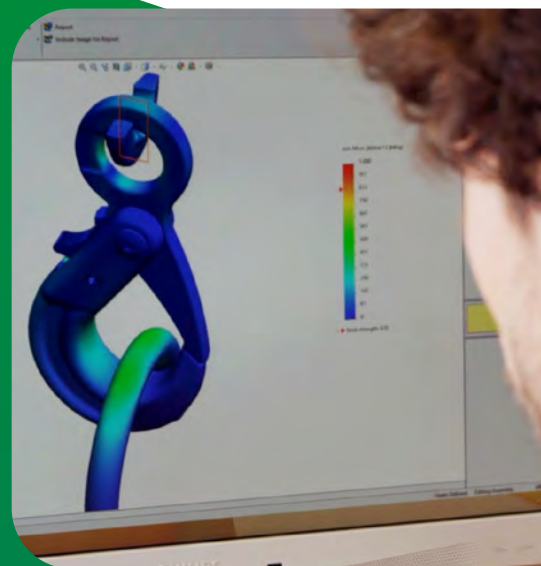
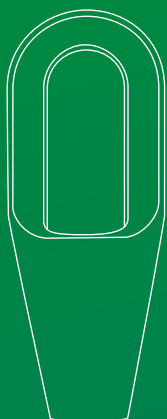



# THE GREEN PIN® HISTORY

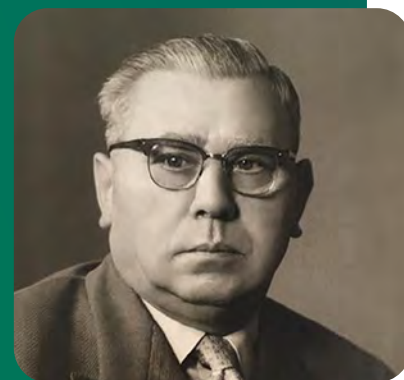

Green Pin® can trace its origins back to 1922. In Sliedrecht, which is located right at the heart of the Dutch maritime industry, blacksmith Dirk van Beest started producing components for dredging. He developed the shackles that would later be branded as Green Pin®. Van Beest's company grew quickly, in line with the expansion of the Dutch dredging and maritime industry.

Today, Green Pin® is part of the Royal Van Beest Group and is headquartered in The Netherlands with branches in the United States, France, Germany, Spain and Brazil.

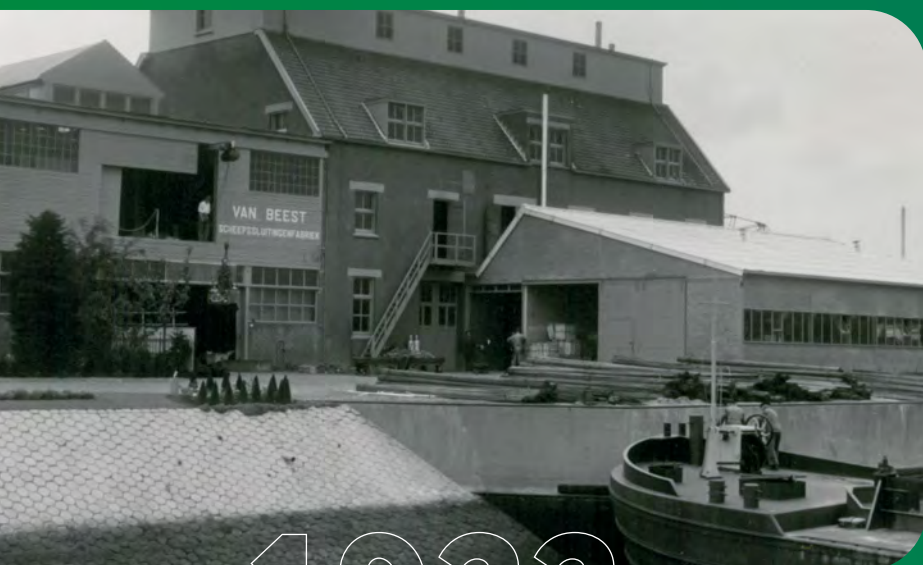

1922



2022



## COMPLEMENTARY PRODUCTS

In addition to the Green Pin® product range of chain and rope fittings, Green Pin®'s corporate parent Royal Van Beest offers complementary products (such as wire rope thimbles, sleeves, general hardware, etc.) to make a lifting assembly complete.

These products are all produced to the specifications indicated in this catalogue and are subject to the quality control of Royal Van Beest. Complementary products are highlighted on the product pages of the catalogue with this icon .

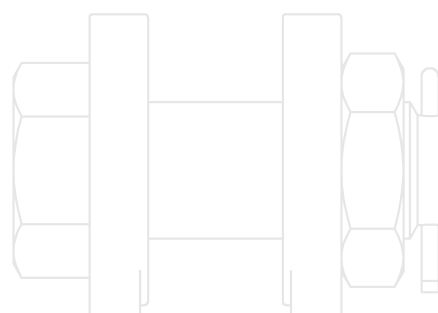
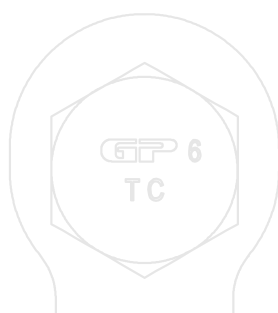

# PROUD MEMBER OF

We are a member of several organizations who promote common interests in our industry. Companies with similar interests come together to share ideas and solutions for industry issues. These organizations spread (technical) information through publications, internet, meetings, and represent the interests of their members on a collective basis. Some of them also organize trade missions, seminars, workshops, member meetings and collective participation in exhibitions worldwide.



Member of



Associated Wire Rope Fabricators



WEB SLING & TIE DOWN ASSOCIATION



# AVAILABLE WORLDWIDE

We believe Green Pin® products should be available to everyone on earth within 72 hours. That's why Green Pin works with the most and the best distributors on this planet. To find the distributor nearest to you, please contact us at: [info@greenpin.com](mailto:info@greenpin.com)



## REFERENCES

Some companies that use our products in projects:

- ADNOC
- Aker Marine Contractors
- Allseas
- BAE Systems
- Bechtel Corporation
- BHP Billiton
- Bluestream Offshore
- Bluewater
- Boskalis
- Bouygues
- BP
- Buckner Heavylift Cranes
- Caterpillar
- Chevron
- Codelco
- ConocoPhillips
- Delmar Systems
- EDF
- Eiffage
- Equinor
- ExxonMobil
- Fluor
- Fugro
- General Electric
- Heerema Marine Contractors
- Hyundai Heavy Industries
- InterMoor
- Jumbo
- Kiewit
- Lamprell
- Liebherr
- Mammoet / ALE
- Manitou
- McDermott
- Nordex
- NOV
- NPCC
- Oceaneering
- Pacific Drilling
- Rio Tinto
- Saipem
- Sapura Energy
- Saudi Aramco
- Schlumberger
- Shell
- Siemens
- SpaceX
- Subsea 7
- Tata
- TechnipFMC
- TotalEnergies
- Transocean
- US Steel
- Van Oord
- Vestas
- Vinci
- Wood Group

# INSIGHTFUL AND HANDS-ON GREEN PIN® TRAINING

Green Pin® seminars and webinars give you the chance to improve your knowledge and discover new features about Green Pin® products and instruct you on how to operate them safely and properly. The training also provides you with insights into the engineering and production technology that goes into manufacturing them.

All sessions are interactive: they allow you to ample opportunities to ask any questions you have, or put forward any challenges that you have faced in the past to knowledgeable presenters.

Organized online via webinar, via a hybrid set-up, or face-to-face at a Green Pin® location or an external venue, there's always a seminar to be found or to be created that fits your schedule and location. In case you want to use the training for accreditation points we can supply you with an official Green Pin® certificate of participation.



## Available Green Pin® training

Green Pin® seminars and webinars are available in several pre-defined formats as shown in the table below. However, completely customized training can also be made. Such sessions allow us to focus on precisely those challenges that you and your colleagues have questions about.

E-mail [info@greenpin.com](mailto:info@greenpin.com) for any inquiries.

Green Pin® Training	What will you learn?	Industry focus	Duration
Shackles	The complete resource on Green Pin® shackles. Topics include the product range, production method, design, testing, instructions for use, certifications and inspection.	All	Two parts of 1 hour each
ROV Shackles and Hooks	An overview of all the shackles and hooks specially designed for Remotely Operated Vehicles, includes many pointers for the most effective use of the products.	Subsea, Offshore	1 hour
Aquaculture Range	Overview of all products specially designed for fishing and aquaculture. Extremely safe products and designed for long use underwater.	Fishing, Aquaculture	1 hour
Chain Fittings	Overview of complete chain fittings range, production method, design, testing, instructions for use, certifications and inspection.	All	Two parts of 1 hour each
Catch Shackle	Reducing the number of injuries and possible deaths by preventing objects from falling with the Catch shackle when assembly or disassembly during installation at a height.	Onshore and Offshore installations	45 min
Fixed Nut Shackles	The benefits, functionality and applications of this extremely secure way of fastening a shackle bolt for permanent use.	Multiple but mostly Marine, Offshore	1 hour
Heavy Duty Master Links	Overview of the range and features that make this forged master link unique in its class.	Offshore	1 hour
Green Pin Tycan® Chain	The complete resource on Green Pin Tycan® fibre chain for lashing and lifting; topics include the product range, design, testing, instructions for use, certifications, inspections and project examples.	All	1 hour
Power Sling® Shackles	Improving rigging safety and saving wire rope costs with the most innovative heavy-lifting shackle in the industry. The session covers this and other benefits, design features, certifications and application instruction.	Offshore, Wind	1 hour
General introduction	The benefits of Green Pin®, usage in various industries and a general overview of the assortment.	All	1 hour
Royal Van Beest Group	Background on Green Pin®'s corporate parent, the Royal Van Beest Group: its history, current operations, subsidiary companies and their products.	All	1 hour
Tailormade webinars	A tailormade session focused on your specific topic of interest or zooming in on a technical challenge you have faced with our type of products (conditions apply).	-	-

# INTRODUCTION

## General

In case you do not use the products yourself but are reselling these as part of a manufactured product, please take our general cautions and warnings into account and make these known to your customers as well. In any case, we do not accept any responsibility or liability, nor can we be held responsible for any misuse or damage with, by or at your customers due to negligent use.

## Definitions

### Material

Various raw materials are used for the production of shackles, hooks and other lifting devices, depending on the use of the finished product. The following raw materials may be used:

- Mild steel, untreated, grade 3;
- High tensile steel, untreated or normalized, grade 4;
- High tensile steel, quenched and tempered, grade 6;
- Alloy steel, quenched and tempered, grade 8;
- Alloy steel, quenched and tempered, grade 10;
- Stainless steel AISI316L, AISI316 or Duplex 1.4462, grade 5.

### Load

Following terms are used to define a load:

- Working Load Limit or WLL: the maximum load the product is designed to sustain, in general use and in in-line lifting.
- Proof Load or PL: this is the load applied on proof testing the product. At this load the product may not show visual deformation. For information about the proof load applied, we refer to the separate paragraph on testing.
- Minimum Breaking Load or MBL: the minimum load at which the product may fail or no longer sustain the load. Where applicable the MBL is specified.
- Shock Load: a sudden impact of the load on the lifting product. Shock loads are to be avoided at all times since they increase the stress on the product significantly and may affect its product life.

The unit that is used in this catalogue to indicate WLL, PL and MBL is t, which stands for metric tonne.

### Safety factor

This indicates the ratio between the MBL and the WLL. For example, the standard range of Green Pin® shackles has a the safety factor of 6:1. This means that the shackle may only fail to retain the load, when the load is in exceedance of at least 6 times its designed WLL. Green Pin® chain fittings generally have a safety factor of 4:1 (lifting eyes have a safety factor of 5:1).

### Product dimensions

All product dimensions mentioned in this catalogue are nominal dimensions. Product design, materials and/or specifications may be changed without prior notification. You can find the most up to date information including CAD-drawings on [greenpin.com/products](https://www.greenpin.com/products).

### Finish

Products can have the following finish:

- Self-coloured: the product is delivered in the condition as it has been forged or machined and has undergone no specific finish treatment.
- Electro-galvanized: the finished product is electro-galvanized according to the customary standards. The thickness of the galvanization is at least 5 µm.
- Hot dipped galvanized: the finished product is hot dipped galvanized according to the customary standards. The thickness of the coating is at least 70 µm.
- Painted: the finished product is painted in a specific colour.
- Polished: stainless steel products are polished.

### Standard

These refer to the specific standards indicated for the product.

### Temperature range

This indicates the temperature range at which the product can be used. Beyond the advised temperature range the WLL of a product may be affected.

## Abbreviations

The following abbreviations are used in this catalogue:

### Product class abbreviations (for example, G-4161)

C Carbon steel  
A Alloy steel  
R Stainless steel  
S Self-coloured  
P Painted  
E Electro-galvanized  
G Hot dipped galvanized

### Product name abbreviations (for example, Green Pin® Bow Shackle BN)

BN	Bolt & Nut or safety bolt	HH	Hook-Hook
CL	Clevis	HK	Hook
CP	Cotter Pin	H-type	Horizontal
D	D-Handle	JJ	Jaw-Jaw
E	Eye	ROV	Remotely Operated Vehicle
EE	Eye-Eye	RT	Recessed Trigger
EJ	Eye-Jaw	S	Shackle
EH	Eye-Hook	S/S	Stainless Steel
F	Fishtail handle	SC	Screw Collar or Screw Pin
FN	Fixed Nut	SCL	Swivel Clevis
FP	Flush Pin	SE	Swivel Eye
GR5	Grade 5	SQ	Square headed Screw Pin
GR8	Grade 8	U-type	Universal (Horizontal and Vertical)
GR10	Grade 10	V-type	Vertical

## Certificates

Our company is ISO certified by Lloyd's; currently we are ISO 9001-2015 certified. Depending on the type of product and certificate availability for a certain product, below mentioned certificates can be provided.

Type 2.1	2.1	<b>Works certificate to EN 10204</b> Statement of compliance with the order.
Type 2.2	2.2	<b>Works certificate to EN 10204</b> Statement of compliance with the order, stating the results of non-specific inspection.
Type 3.1	3.1	<b>Inspection certificate to EN 10204</b> Statement of compliance with the order, stating the results of material specific inspection. This includes chemical composition and mechanical properties at component level.
Type MTC a	MTC <sup>a</sup>	<b>Manufacturer test certificate</b> Statement of compliance with the order, stating the results of proof load testing samples of a production batch. Products are not individually tested.
Type MTC b	MTC <sup>b</sup>	<b>Manufacturer test certificate</b> Statement of compliance with the order, stating the results of individual proof load testing.
Type LROS	LROS	<b>Proofload Statement</b> Statement of witness of proof load testing and visual examination by a surveyor from Lloyds Register, stating the results of individual proof load testing.
Type DNV PL	DNV PL	<b>Proofload Statement</b> Statement of witness of proof load testing and visual examination by a surveyor from DNV, stating the results of individual proof load testing. For P-6043, these shackles are proof load tested with presence of a DNV surveyor.
Type MPI a	MPI <sup>a</sup>	<b>Non-destructive testing report</b> Statement of compliance with the order, stating the results of Magnetic Particle Inspection (M.P.I.) in accordance with EN 10228-1 on samples of a production batch. Products are not individually tested.
Type MPI b	MPI <sup>b</sup>	<b>Non-destructive testing report</b> Statement of compliance with the order, stating the results of individual Magnetic Particle Inspection (M.P.I.) in accordance with EN 10228-1.

Table continues on next page

Type US a	US <sup>a</sup>	<b>Non-destructive testing report</b> Statement of compliance with the order, stating the results of Ultrasonic Inspection (U.S.) in accordance with EN 10228-3 on samples of a production batch. Products are not individually tested.
Type US b	US <sup>b</sup>	<b>Non-destructive testing report</b> Statement of compliance with the order, stating the results of individual Ultrasonic Inspection (U.S.) in accordance with EN 10228-3.
Type DNV 2.7-1 a	DNV 2.7-1 <sup>a</sup>	<b>Type Approval certificate to DNV 2.7-1</b> Green Pin® Standard Shackles, Green Pin Polar® Shackles, DNV Master links and DNV Master link assemblies are DNV Type approved to DNV standards DNV-ST-E271-2.71 Offshore containers and DNV-ST-E273 Portable offshore units. DNV Type approval certificates TAS000033J and TAS00003F7.
Type DNV 2.7-1 b	DNV 2.7-1 <sup>b</sup>	<b>Type Approval certificate to DNV 2.7-1</b> Statement of compliance with the order, of Green Pin® Standard Shackles and Green Pin Polar® Shackles, DNV Type approved to DNV standards DNV-ST-E271-2.71 Offshore containers and DNV-ST-E273 Portable offshore units. Stating the results of proof load testing samples of a production batch. Products are not individually tested.
Type DNV 0377	DNV 0377	<b>Type Approval certificate to DNV 0377</b> Green Pin Power Sling® shackles are DNV Type approved to DNV Standard DNV-ST-0377 Standard for shipboard lifting appliances. DNV Type approval certificate TAS000018M. Former DNV Certification No 2.22, Lifting Appliances – Application – Loose gear for offshore cranes.
Type DNV 0378	DNV 0378 DNV CG3	<b>Type Approval certificate to DNV 0378</b> Green Pin® Standard Shackles, Green Pin Polar® Shackles and Green Pin Power Sling® shackles are DNV Type approved to DNV Standard DNV-ST-0378 – Standard for offshore and platform lifting appliances. DNV Type approval certificates TAS00001H7 and TAS000018M. Former DNV Certification No 2.22, Lifting Appliances – Application – Loose gear for offshore cranes.
Type NYTEK / NS 9415	DNV NS 9415	<b>Type Approval certificate to NYTEK-regulation and NS 9415</b> Green Pin® products, (G-4139, G-8310, G-4863, G-4163BG and G-6870), are primarily used for Aquaculture applications. These products and the Royal Van Beest management system are certified by DNV for compliance with NYTEK-regulation and NS 9425 standard. DNV approval certificate PRONO 121.
Type DGUV	DGUV	<b>DGUV Type test certificate to EN 1677</b> Many Green Pin® chain sling components have a DGUV type approval certificate. Tests are based on GS-OA-15-05:2012-05: Principles for the testing and certification of chains and chain components. These components are Type approved to EN 818-2 or EN 1677 and are entitled to be marked H94.
Type CE IIA	CE IIA	<b>CE Declaration of Conformity</b> CE Declaration of Conformity in accordance with annex IIA of the Machinery Directive 2006/42/EC and the latest amendments.
Type CE IIB	CE IIB	<b>CE Declaration of Incorporation</b> CE Declaration of Incorporation in accordance with annex IIB of the Machinery Directive 2006/42/EC and the latest amendments.
Type BL	BL	<b>Break Load test certificate</b> A certificate with the actual breaking load results on tested samples.
Type ABS PDA	ABS PDA	<b>Certificate of Product Design Assessment Approval</b> The Green Pin® Standard Shackles G-4161, G-4163, G-4151, G-4153; The Green Pin Polar® Shackles G-5163 and the Green Pin Super® Shackles G-5261 and G-5263 are ABS Type Approved. Intended service: Loose Gear Items. Use on Lifting Equipment. ABS PDA certificates 23-2397435-PDA, 23-2397436-PDA and 23-2397437-PDA.
Type ABS MA	ABS MA	<b>Certificate of Manufacturing Assessment Approval</b> ABS MA certificate 18-RO 3524956.

## Conditions

Certificate types 2.1, 2.2, 3.1, MTC a, DNV 2.7-1 a, DNV 2.7-1 b, DNV 0377, DNV 0378, DNV NS 9415, DGUV, ABS PDA, ABS MA and CE can be supplied at no extra charge. For all other certificates, additional costs will be charged.

### Free of charge:

2.1 2.2 3.1 MTC<sup>a</sup> DNV 2.7-1<sup>a</sup> DNV 2.7-1<sup>b</sup> DNV 0377 DNV 0378 DNV NS 9415 DGUV CE IIA CE IIB ABS PDA ABS MA

### With additional charges:

MTC<sup>b</sup> LROS MPI<sup>a</sup> MPI<sup>b</sup> US<sup>a</sup> US<sup>b</sup> DNV CG3 BL

On request the proof load test certificates can be supplied surveyed by an official classification society, such as LROS, DNV, BV, ABS or any other officially certified inspection body. Specific details of certificate availability can be found in each product chapter. Please verify your certification requirements at the time of order. For more information and specifications, see the table below for an overview of the different test methods.

Test method	Test type	Test description	Document
Visual inspection	Non Destructive	The products are inspected and approved by our QC-department. The products are inspected and approved by our QC-department, stating the results of non-specific inspection.	2.1 2.2
Material specific inspection	Destructive	The material of the products is inspected. This includes chemical composition and mechanical properties at component level.	3.1
Proof Load test	Non Destructive	Samples of a production batch of products are proof load tested. Products are not individually tested. All products of a production batch are individually proof load tested.	MTC <sup>a</sup> MTC <sup>b</sup>
Magnetic Particle inspection	Non Destructive	Samples of a production batch of products are Magnetic Particle Inspection (M.P.I.) tested in accordance with EN 10228-1. Products are not individually tested. All products of a production batch are individually Magnetic Particle Inspection (M.P.I.) tested in accordance with EN 10228-1.	MPI <sup>a</sup> MPI <sup>b</sup>
Ultrasonic inspection	Non Destructive	Samples of a production batch of products are Ultrasonic Inspection (U.S.) tested in accordance with EN 10228-3. Products are not individually tested. All products of a production batch are individually Ultrasonic Inspection (U.S.) tested in accordance with EN 10228-3.	US <sup>a</sup> US <sup>b</sup>
Break Load test	Destructive	Samples of a production batch are break load tested.	BL

## CAD drawings

Green Pin® products are used in a wide variety of applications; from a simple lift to move an item from A to B in a workplace, to very complex lifting systems for offshore applications. In the latter case, engineers use Computer Aided Design (CAD) software to develop a 2D or 3D specification of the entire system.

For standard products engineers normally use a CAD drawing library. The use of this kind of libraries saves considerable design time and costs. And of course it prevents mistakes that may occur whilst copying data from a product catalogue into the design program.

To help engineers, Green Pin® has made CAD drawings available in various formats (e.g. STEP, IGS, CATIA, etc.) on the Green Pin® website ([www.greenpin.com](http://www.greenpin.com)). These drawings can be integrated in almost every design program. Further details can be obtained through our website: [www.greenpin.com/cad](http://www.greenpin.com/cad).

### CAD

In the product chapters the CAD icon indicates that cad drawings are available.

### RFID

## RFID

Green Pin® offers an identification solution with an easily accessible Radio Frequency Identification (RFID) chip in our range of Green Pin® Shackles. The RFID icon in the product chapters indicates that the products can be equipped with a countersunk RFID chip.

For more information see page 24.

### INFO

## More information

For some products we provide detailed technical information on our website. In the product chapters the INFO icon indicates that there is extra information on this product available at [www.greenpin.com/FAQ](http://www.greenpin.com/FAQ).

## General cautions and warnings

All WLL's indicated in this catalogue or in other Green Pin® literature or publications are only applicable to recently-supplied, new and unused products used under prescribed operating conditions. Any extreme circumstances or shock loading that occur during use must be taken into account when specifying the products to be used.

The WLL should be applied in in-line lifting. Overloads must be avoided. Side loads should be avoided too, as the products are not designed for this purpose and the application of a side load may significantly decrease product life. The WLL of the product represents the limit in static use. In case of dynamic use (breaking, accelerations, shocks), the effective stress on the product increases significantly which can lead to product failure.

Products must be regularly inspected in accordance with the safety standards valid in the country of use. This is required because the products in use may be affected by wear, misuse, overloading etc. which may lead to deformation and alteration of the material structure. Inspection should take place at least every six months and more frequently when the products are used in severe operating conditions.

Green Pin® is constantly improving products to make sure they meet the latest industry standards. Therefore some dimensions or product markings may differ from those stated in this catalogue. The characteristics mentioned in this catalogue or in other Green Pin® literature or publications are given merely as an indication. Green Pin® reserves the right to make any suitable modification to any product, even after acceptance of the customer order. The essential characteristics and performances of the products shall not be negatively affected by such modifications. Any critical dimensions or characteristics should be verified with our engineering department before ordering the product.

Green Pin® products are typically used to transfer loads during lifting, lashing or towing. These fittings are usually combined with steel wire rope, chain or synthetic rope or chain (Green Pin Tycan® chain) to form a lifting sling. You must therefore conduct the following verifications to safely use the products:

### Verification before first use

Before first use of the sling it should be ensured that:

- The sling meets the exact requirements specified in the order;
- The valid manufacturer certificate and CE declaration are at hand;
- The identification and the WLL mentioned on the sling correspond to the information stated on the certificate;
- Full details of the sling (components, diameter, number of legs, angle, grade) are recorded in the register of lifting equipment;
- The users of the sling have received appropriate instruction and training.

### Verification before each use

Before each use the sling should be visually inspected for obvious damage or deterioration. If faults are found during this inspection, the sling should be withdrawn from service and referred to a competent person for thorough examination. Some parts can be replaced or the complete sling can be discarded.

A thorough inspection should be carried out by a competent person at intervals not exceeding six months and more frequently when the slings are used in severe operation conditions. Records of such inspections should be maintained. Slings should be thoroughly cleaned to remove any oil, dirt or rust prior to inspection. Any cleaning method which does not damage the material is acceptable. Avoid the use of acids, overheating, removal of metal or movement of metal which may cover cracks or surface defects.

The sling should be inspected throughout its full length to detect any evidence of wear, distortion or external damage.

Any replacement component or part of the sling should be in accordance with the appropriate European Standard or the safety standards given in the country of use for that component or part. If a chain link in one of the legs of a chain sling is damaged, then the entire chain leg should be replaced. The repair of a link in a welded chain sling should exclusively be carried out by the chain manufacturer using the adequate welding process. Components showing any defects should be discarded and replaced. When replacing a mechanically assembled component, always use a replacement component that meets the certification requirements of the sling.

### Handling of the load

- It is important to check the sling before lifting. Check if the manufacturer of the load indicates any specific instructions for the lifting of the load. Before starting the lift, make sure that the load is free to move and is not bolted down. Also check if no loose objects could fall down from the load. The path between the current location of the load and the new one must be free.
- The weight of the load must be known in order to select a sling with the correct WLL. If the weight of the load is not marked, the information should be obtained from the consignment notes, manuals or drawings, or assessed by calculation.
- Please observe the centre of gravity of the load. To prevent any tilting or toppling, the following conditions should be met:
  - for single leg slings and endless slings the lifting point should be positioned directly above the centre of gravity.
  - for two leg slings the lifting points should be positioned on both sides of, and higher than, the centre of gravity.
  - for three and four leg slings the lifting points should be distributed in a plane around the centre of gravity. Distribute the weight evenly over the lifting points, which should be placed higher than the centre of gravity.
- When using multi leg slings make sure that the angles between the lifting points and sling legs are within the range marked on the sling. The angle  $\beta$ , which is the angle between the sling leg and the vertical, should never exceed 60°. Details about load reductions for slings at certain angles can be found in the tables corresponding to the relevant chain grade.
- Use the below reduction table if a multi leg sling is not used for the purpose for which it has been designed, for example for a lifting operation with fewer legs than the number of legs of the sling:

Types of chain sling	Number of legs used	Factor to apply to marked WLL
Two-leg	1	1/2
Three- and four-leg	2	2/3
Three- and four-leg	1	1/3

- The sling should at least have a WLL equal to or greater than the weight to be lifted.
- Ensure that the load to be moved is able to resist both the vertical and horizontal force without being damaged.
- A suspended load should not be left unattended.
- Riggers should be aware of the risks and dangers of shock loading which may lead to failure of the sling. The load should always be lifted and lowered slowly.

### Method of connection

- A sling is usually attached to the load with endfittings such as hooks and/or links.
- The components should be used for in-line loading only in order to avoid bending.
- The lifting points fixed on the load should be seated well in the load bearing part of the hook (never on the tip of the hook or wedged in the opening of the hook).
- We refer to the detailed warnings of each component in the product chapters.

### Symmetry of loading

The WLL values mentioned in our catalogue for each grade have been determined on the basis that the loading of the sling is symmetrical. This means that when the load is lifted the sling legs are symmetrically distributed in the plane and all legs of the sling have the same angles to the vertical. For chain slings refer to EN 818-6:2000+A1:2008 for more details.

The loading can be assumed to be symmetric if all of the following conditions are met:

- the load is less than 80% of marked WLL and
- sling leg angles to the vertical are all more than 15° and
- sling leg angles to the vertical are all within 15° to each other and
- in the case of three- and four- leg slings, the plane angles are within 15° of each other.

If one of the above parameters is not met, the loading should be considered to be asymmetric and the lift should be referred to a competent engineer to establish the safe rating for the sling. Alternatively, in the case of asymmetric loading, the sling should be derated to half the marked WLL. If the load tends to tilt during the lift, it should be lowered and the attachments changed by repositioning the attachment points or by using compatible shortening devices. The safety factor on the individual components is designed for safety only. Never exceed the indicated WLL.

### Safety of lift

Hands and other body parts should be kept away from the chain to prevent injuries. The load should be lifted slowly until the sling leg is taut. As soon as the load is slightly raised, check that it is secure and has the desired position. Refer to ISO 12480-1 for planning and management of the lifting operation and for a safe way of executing it. Never move the load over people during the lift.

### Lowering the load

The point of destination of the load should be prepared and should be adapted to the weight and shape of the load. The access to this site must be clear of any unnecessary obstacles and people. The load should be lowered carefully. Avoid trapping the sling beneath the load as this may cause damage to the load or sling. Before taking the tension off the sling legs, the load should be checked to ensure that it is properly supported and stable. The sling should be removed by hand and not with the lifting device. The load should not be rolled off the sling as this may damage the sling.

### Storage of slings

When not in use slings should be kept on a properly designed rack. They should not be left lying on the ground where they may be damaged. If the slings are left suspended from a crane hook, the sling hooks should be engaged in an upper link to reduce the risk of sling legs swinging freely or snagging. If the slings are out of use for some time they should be cleaned, dried and protected from corrosion, e.g. lightly oiled.

### Maintenance

Slings must be regularly inspected in accordance with the safety standards valid in the country of use.

A competent engineer should examine the sling, observing the following:

- the sling markings (ID, WLL) must be legible;
- there may be no distortion of the upper or lower end fittings;
- sling leg stretch and wear may not exceed the tolerances.

If the identification tag of the sling is missing and the necessary information is not marked on the sling itself, the sling should be withdrawn from service. Use original Green Pin® spare kits to replace parts (such as a load pin or the latch of a hook) or if a load pin is misused, damaged or distorted.

### Limitations in use

- Never modify components by welding, heat treating, grinding or any other process. It could alter their mechanical and/or chemical characteristics;
- Consult Green Pin® if the sling is to be exposed to highly concentrated chemicals. Green Pin® products may not be used under chemical influences such as acids or alkaline solutions;
- The rating of lifting accessories in European Standards assumes the absence of exceptionally hazardous conditions. This concerns offshore activities, lifting of persons and lifting of potentially dangerous loads. In such cases the degree of hazard should be assessed by a competent engineer and the WLL adjusted accordingly;
- If a product is used under extreme temperature conditions, the WLL must be reduced. We refer to the relevant product chapter in this catalogue for guidance on use at extreme temperatures.

## Conversion factors

		To convert	
from	to	multiply by	
<b>Length</b>			
mm	inch	0.0393701	
inch	mm	25.4	
<b>Mass</b>			
US tonnes	metric tonnes	0.9071847	
metric tonnes	US tonnes	1.1023113	
metric tonnes	pounds	2204.6226218	
pounds	metric tonnes	0.0004536	
metric tonnes	kilogram	1000	
kilogram	metric tonnes	0.001	
metric tonnes	kilo Newton	9.8066500	
kilo Newton	metric tonnes	0.1019716	
pounds	kilogram	0.4535924	
kilogram	pounds	2.2046226	
<b>Temperature</b>			
Celcius	Fahrenheit	1.8 + 32	
Fahrenheit	Celcius	$(-32) * 0.5555556$	
<b>Torque</b>			
Newton meter	foot pound-force	0.7375621	
foot pound-force	Newton meter	1.3558180	

# LIFTING SLING FITTINGS

## Applications

Lifting sling fittings are used for the manufacturing of steel chain, Green Pin Tycan® chain, synthetic or steel wire rope slings. With the lifting sling fittings, you can manufacture different configurations; for example, 1 and 2 leg slings or 3 and 4 leg slings. Depending on the type of sling, chain or steel wire rope the fittings have a safety factor of 4 or 5.

## Range

Green Pin® offers a wide range of lifting sling fittings such as chain fittings, thimbles, wire rope clips, sleeves, sockets etc. With the wide range of lifting sling fittings, a complete sling from the top master link to the hooks can be assembled.

To complement the Green Pin® assortment, Royal Van Beest also offers a wide range of other (commercial) lifting components.

## Finish

The finish of the lifting components is either self-coloured, painted, electro-galvanized or hot dipped galvanized. You can find the finish per product on the product page itself.

## Certification

Specific details of certificate availability can be found on each product page. Please verify your certification requirements at the time of order.

## Index

To create an easy overview that shows directly which products can be used per type of chain, this chapter has been split up in five subchapters.

Please find below which type of products can be found per subchapter.

### 3.1 For Wire Rope

In the wire rope subchapter, you will find the components which can be used to make a wire rope sling.

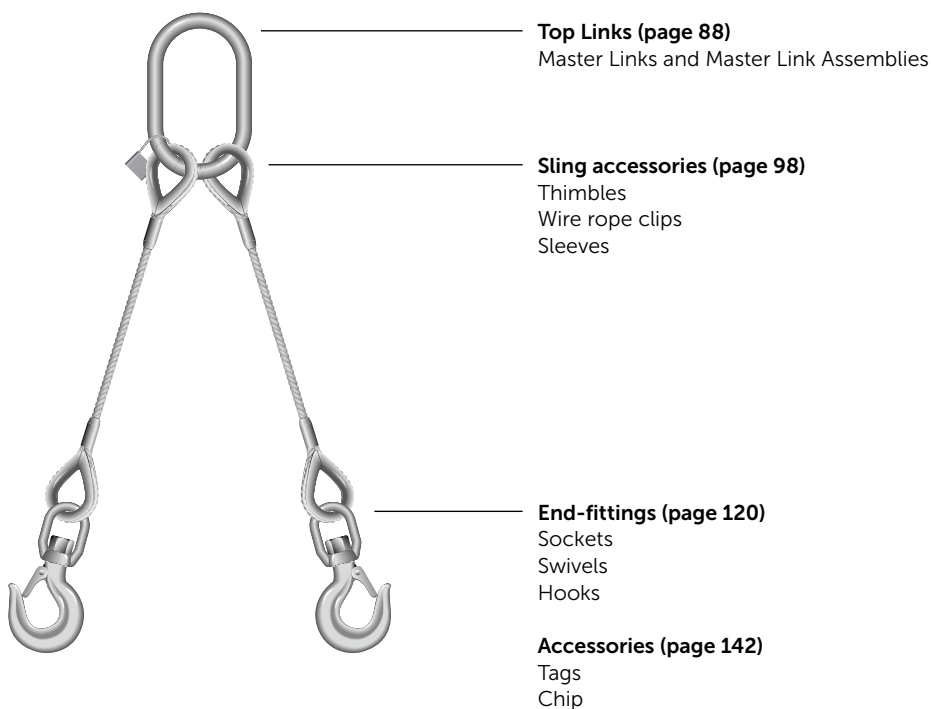

### 3.2 For Grade 8 chain

In the grade 8 subchapter, you will find the components which can be used to make a grade 8 steel chain sling.



**3.3 For Grade 10 chain**

In the grade 10 subchapter, you will find the components which can be used to make a grade 10 steel chain sling.

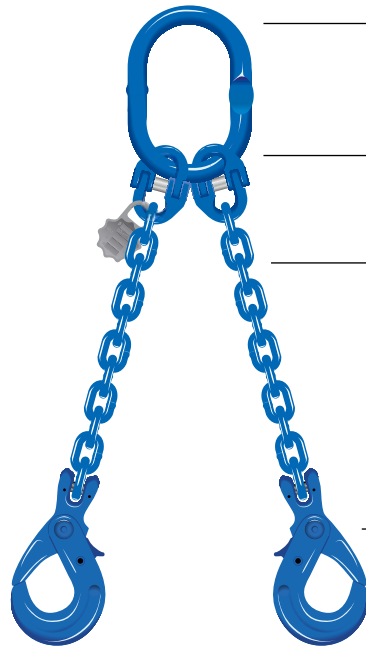

- Top Links (page 180)**  
Master Links and Master Link Assemblies
- Connectors (page 184)**  
Links
- Chain (page 185)**  
Grade 10 steel chain
- Shorteners (page 186)**  
Shortening hooks  
Shortening clutches
- End-fittings (page 189)**  
Hooks
- Accessories (page 195)**  
Tags  
Chip  
Spareparts

**3.4 For Green Pin Tycan® chain**

In the Green Pin Tycan® subchapter, you will find the components which can be used to make a Green Pin Tycan® lifting fibre chain sling.

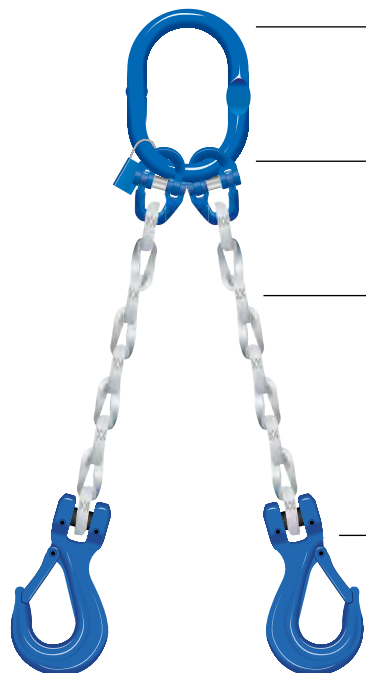

- Top Links (page 208)**  
Master Links and Master Link Assemblies
- Connectors (page 212)**  
Links
- Chain (page 214)**  
Green Pin Tycan® fibre lifting chain
- Shorteners (page 215)**  
Shortening hooks
- End-fittings (page 216)**  
Hooks
- Accessories (page 219)**  
Tags  
Chip  
Spareparts

### 3.5 For synthetic slings

In the synthetic sling subchapter, you will find the components which can be used to make a synthetic sling chain.

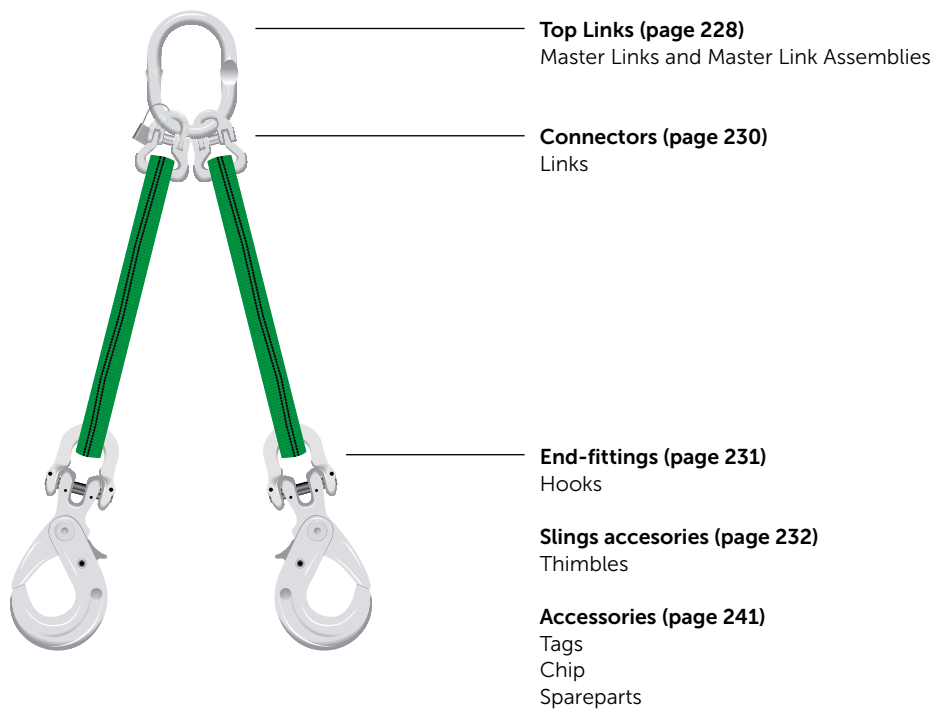

# LIFTING SLING FITTINGS FOR WIRE ROPE

## Applications

Green Pin® fittings for wire rope slings enable the assembly of a complete wire rope sling from the top master link to the hooks. Wire rope slings are often used for rigging and lifting applications that require heavy-duty slings that are abrasion-resistant but still flexible.

Specific product information can be found on the page mentioned in the following product groups overview.

3.1





















Top links					
 <b>MS</b> page 88	 <b>MTS</b> page 89	 <b>UMS</b> page 90	 <b>UMTS</b> page 91	 <b>UMSW</b> page 92	 <b>UMTSW</b> page 93
 <b>P-6810</b> page 94	 <b>P-6820</b> page 95	 <b>P-6815</b> page 96			
Sling accessories					
 <b>E-6110</b> page 98	 <b>G-6120</b> page 98	 <b>G-6128</b> page 99	 <b>E-6131/G-6131</b> page 100	 <b>S-6134</b> page 101	 <b>E-6135/G-6135</b> page 102
 <b>G-6170</b> page 103	 <b>G-6142</b> page 104	 <b>G-6151</b> page 104	 <b>P-6190</b> page 105	 <b>P-6195</b> page 105	

Table continues on next page

					
<b>G-6240</b> page 109	<b>E-6260</b> page 110	<b>E-6220</b> page 111			
					
<b>S-6500</b> page 113	<b>A-6550</b> page 114				
End-fittings					
					
<b>G-6411</b> page 120	<b>G-6412</b> page 121	<b>G-6422</b> page 122	<b>G-6413</b> page 123	<b>G-6423</b> page 124	<b>G-6419</b> page 125
					
<b>G-6429</b> page 126	<b>G-6416</b> page 127	<b>S-6414</b> page 128	<b>S-6415</b> page 129		
					
<b>G-7713</b> page 131	<b>G-7723</b> page 131	<b>G-7733</b> page 132	<b>P-7740</b> page 132		
					
<b>CSO</b> page 135	<b>CSE</b> page 135	<b>P-6714A</b> page 136	<b>P-6703A</b> page 137	<b>XLO</b> page 138	<b>GKO</b> page 138
					
<b>XLE</b> page 139	<b>GKE</b> page 139	<b>P-6706A</b> page 140	<b>P-6714C</b> page 141		
Accessories					
					
<b>TAG</b> page 142	<b>TAGRFID</b> page 143	<b>CHIPRFID</b> page 143			

## Instructions for use

When chain fittings with a safety factor of 4 : 1 are used in combination with steel wire rope the WLL must be reduced by 20 %. This is the difference between a design factor of 4 : 1 (for chain slings) and 5 : 1 (for steel wire rope slings).

See table below:

Working Load Limit (t)		Minimum Breaking Load (t)
4 : 1 Safety factor	5 : 1 Safety factor	
1.12	0.896	4.48
1.25	1	5
1.6	1.28	6.4
2	1.6	8
2.5	2	10
3.2	2.56	12.8
3.5	2.8	14
3.65	2.92	14.6
4.5	3.6	18
5.4	4.32	21.6
6.2	4.96	24.8
6.5	5.2	26
6.8	5.44	27.2
8.2	6.56	32.8
8.5	6.8	34
10	8	40
10.6	8.48	42.4
11	8.8	44
11.2	8.96	44.8
11.5	9.2	46
12.8	10.24	51.2
13	10.4	52
15.5	12.4	62
16	12.8	64
17	13.6	68
17.7	14.16	70.8
20	16	80
20.8	16.64	83.2
21.2	16.96	84.8
21.6	17.28	86.4
22	17.6	88
25	20	100
27.6	22.08	110.4
30	24	120
31.5	25.2	126
32.8	26.24	131.2
37	29.6	148
40	32	160
41.6	33.28	166.4
50	40	200
60	48	240
63	50.4	252
80	64	320
100	80	400
125	100	500



## LIFTING SLING FITTINGS FOR WIRE ROPE

# MASTER LINKS & MASTER LINK ASSEMBLIES



## Applications

Master links are the connection between the (crane) hook and wire rope fittings. The Green Pin® wire rope master links have a large opening to accommodate for larger lifting points and crane hooks. The welded master link designed for 1 or 2 legs and the master link assembly for 3 or 4 legs. A flat part on the link enables assembly with an omega link or with a thimble.

More information about the range, certification and finish, please go to the introduction of chapter 3 lifting slings.

## Design

The Green Pin® Wider Master Link and Master Link Assembly are grade 10 master links with larger inside dimensions.

The Green Pin® DNV Master Link and Master Link Assembly are grade 8 master links and are perfect for offshore use. This welded master link is DNV-certified.

The Green Pin® Heavy Duty Master Link is a grade 8 master link for heavy-duty applications. The consistent Charpy V value of at least 42 J at -20 °C and 27 J at -40 °C throughout the entire master link, makes it compliant with offshore certification requirements. The master links are fully forged as a single piece.

Wire rope master links are generally marked with:

- manufacturer's symbol - e.g. GP
- size in mm and/ or inch - e.g. 25 and/or 1"
- traceability code - e.g. HA
- steel grade (specific products) - e.g. 8 or 10
- item code (specific products) - e.g. UMSW

As prescribed by the Machinery Directive 2006/42/EC our hooks, master links and connecting links are supplied with a CE Declaration of Incorporation (CE IIB), stating the products are in compliance with the requirements of the machinery directive. These products do not have a CE marking, since CE markings are only to be provided for machines, whereas hooks, master links and connecting links are components of machines, and not machines themselves. Providing components with a CE marking is an incorrect interpretation of the Machinery Directive.

Machinery definition according to Machinery Directive 2006/42/EC – Article 2 – definitions (a) and Machinery Regulation 2023/1230/EU

“An assembly of linked parts or components, at least one of which moves and which are joined together, intended for lifting loads and whose only power source is directly applied human effort.”

“The maximum working load shall be prominently marked on the lifting machinery. The marking shall be legible, indelible and in an un-coded form. Where the maximum working load depends on the configuration of the lifting machinery, each operating position shall be provided with a load plate indicating, preferably in diagrammatic form or by means of tables, the working load permitted for each configuration.”

This definition means that a sling is a Machine and that the hooks, master links and connecting links are not considered as a machine themselves, but as components of a machine. The CE and the WLL markings in consequence, are mandatory only on the assembled sling tag as the sling is the machine according to MD 2006/42/EC. This rule is still valid with the new Machine Regulation 2023/1230 which will replace the MD cited previously within early 2027.

## Instructions for use

Master links and master link assemblies, should be inspected before use to ensure that:

- all markings are legible.
- Master links and master link assemblies with the correct WLL has been selected with respect to the sling design.
- Master links and master link assemblies are free from nicks, gouges, and cracks.
- Master links and master link assemblies are not heat treated, modified, repaired, or reshaped by machining or bended. (This may affect their Working Load Limit).
- Master links and master link assemblies are not distorted or unduly worn.

Master links and master link assemblies must be regularly inspected in accordance with the safety standards given in the country of use. This is required because the products in use may be affected by issues such as wear, misuse and overloading, which may lead to deformation and alteration of the material structure. Inspection should take place at least every six months, and more frequently when the links are used in severe operating conditions.

### Symmetry of loading

The WLL values mentioned are based on symmetrical loading of the sling. This means that when the load is lifted the sling legs are symmetrically distributed in the plane and all legs of the sling have the same angle to the vertical. The loading can be assumed to be symmetric if all the following conditions are met:

- the load is less than 80% of marked WLL, and
- sling leg angles to the vertical are all more than 15°, and
- sling leg angles to the vertical are all within 15° to each other, and
- in the case of three- and four-leg slings, the plane angles are within 15° of each other.

If one of the above parameters is not met, the loading should be considered to be asymmetric, and the lift should be referred to a competent engineer to establish the safe rating for the sling. Alternatively, in the case of asymmetric loading, the sling should be derated to half the marked WLL. If the load tends to tilt during the lift, it should be lowered, and the attachments changed by repositioning the attachment points or by using compatible shortening devices. The safety factor of 4 or 5 on the individual components is designed for safety only. Never exceed the indicated WLL.

Use the below reduction table if a multi leg sling for wire rope fittings is not used for the purpose for which it has been designed, for example for a lifting operation with fewer legs than the number of legs of the sling:

Types of chain sling	Number of legs used	Factor to apply to marked WLL
Two-leg	1	1/2
Three- and four-leg	2	2/3
Three- and four-leg	1	1/3



MS

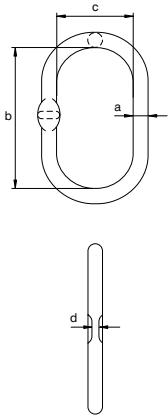

## Green Pin® Master Link EN 1677-4 GR8

### Grade 8 master link EN 1677-4

- **Material:** alloy steel, grade 8, quenched and tempered
- **Safety factor:** MBL equals 4 x WLL
- **Standard:** EN 1677-4, ASTM A952/952M and ASME B30.9
- **Finish:** painted white\*
- **Temperature range:** -40 °C up to +200 °C
- **Certification:** 2.1 2.2 3.1 MTC<sup>®</sup> MPI<sup>®</sup> CE IIB
- **Article code:** scan QR code to see article codes
- **Note:** from 50 t without flat part. For use of this component in a wire rope sling the safety factor must be 5 : 1, see the table on page 84



diameter	diameter chain 1 leg	diameter chain 2 legs		working load limit	length inside	width inside	thickness	weight each
a mm	mm	$\beta \leq 45^\circ$ mm	$45^\circ < \beta \leq 60^\circ$ mm	t	b mm	c mm	d mm	kg
13	6/7	6	6/7	1.6	115	60	7	0.40
16	8	7/8	8	3.2	120	70	7	0.60
18	10	10	10	4.5	135	75	9	0.84
20	13	-	13	6.2	150	82	11	1.10
22	16	13	16	8.2	170	90	14	1.60
25	18	-	18	10.6	190	103	14	2.30
28	20	16	19	12.8	209	120	17	3.10
30	20/22	18	20/22	15.5	235	125	17	4
36	-	19/20	-	20	270	145	22	6.60
38	26	22	26	25	250	150	22	7.10
45	32	26	32	37	300	200	22	12.1
50	-	32	-	50	380	200	-	18
55	-	-	-	63	360	200	-	21
70	-	-	-	100	500	250	-	44
80	-	-	-	125	503	280	-	60.7

CAD INFO

\* Could be (for some sizes) delivered with a yellow or red finish



# Green Pin® Master Link Assembly EN 1677-4 GR8

## Grade 8 master link assembly EN 1677-4

Scan for additional product details



- **Material:** alloy steel, grade 8, quenched and tempered
- **Safety factor:** MBL equals 4 x WLL
- **Standard:** EN 1677-4, ASTM A952/952M and ASME B30.9
- **Finish:** painted white\*
- **Temperature range:** -40 °C up to +200 °C
- **Certification:** 2.1 2.2 3.1 MTC<sup>b</sup> MPI<sup>a</sup> CE IIB
- **Article code:** scan QR code to see article codes
- **Note:** from 60 t without flat part. For use of this component in a wire rope sling the safety factor must be 5 : 1, see the table on page 84

MTS

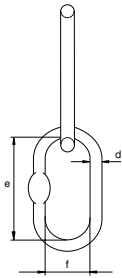
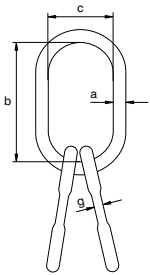

diameter	diameter chain 3/4 legs		working load limit	length inside	width inside	diameter	length inside	width inside	thickness	weight each
a mm	$\beta < 45^\circ$ mm	$45^\circ < \beta \leq 60^\circ$ mm	t	b mm	c mm	d mm	e mm	f mm	g mm	kg
16	6	6/7	2.5	120	70	13	115	60	7	1.20
18	6/7	8	3.5	135	75	16	120	70	7	3.10
22	8	10	6.5	170	90	18	135	75	9	3.30
25	10	13	8.5	190	103	20	150	82	11	4.50
28	-	-	10	209	120	20	150	82	11	5.40
30	13	16	13	235	125	22	170	90	14	7.20
36	16	18/19	17	270	145	25	190	103	14	11.2
38	-	20	20.8	250	150	28	209	120	17	13.3
45	18/20	22	30	300	200	36	270	145	22	25.3
50	22	26	40	380	200	38	250	150	22	32.2
55	26	32	50	360	200	38	250	150	22	35.2
60	-	-	60	430	220	45	300	200	45	54.2
70	32	-	80	500	250	55	360	200	55	86
80	-	-	100	503	250	55	360	200	55	103

CAD INFO

\* Could be (for some sizes) delivered with a yellow or red finish



UMS

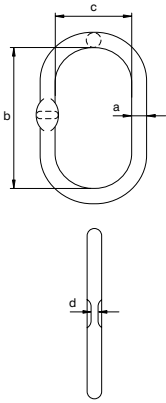

# Green Pin® Master Link GR10

## Grade 10 master link

- **Material:** alloy steel, grade 10, quenched and tempered
- **Safety factor:** MBL equals 4 x WLL
- **Standard:** follows the EN1677 with values for grade 10 and conforms to ASTM A952/A952M and ASME B30.9
- **Finish:** painted blue
- **Temperature range:** -40 °C up to +200 °C
- **Certification:** 2.1 2.2 3.1 MTC<sup>o</sup> MPI<sup>o</sup> CE IIB
- **Article code:** scan QR code to see article codes
- **Note:** for use of this component in a wire rope sling the safety factor must be 5 : 1, see the table on page 84

Scan for additional product details



diameter	diameter chain 1 leg	diameter chain 2 legs		working load limit	length inside	width inside	thickness	weight each
a mm	mm	$\beta \leq 45^\circ$ mm	$45^\circ < \beta \leq 60^\circ$ mm	t	b mm	c mm	d mm	kg
13	6	6	6	2	115	60	7	0.40
16	8	-	8	3.2	120	70	7	0.60
18	10	8	10	5.4	135	75	9	0.84
22	13	10	13	8.2	170	90	11	1.60
25	16	13	16	11.2	190	103	14	2.17
30	18/20	16	18/20	16	235	125	17	4
38	22	20/22	22	27.6	250	150	22	7.10

CAD



# Green Pin® Master Link Assembly GR10

## Grade 10 master link assembly

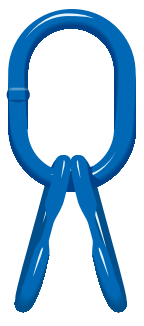

- **Material:** alloy steel, grade 10, quenched and tempered
- **Safety factor:** MBL equals 4 x WLL
- **Standard:** follows the EN1677 with values for grade 10 and conforms to ASTM A952/A952M and ASME B30.9
- **Finish:** painted blue
- **Temperature range:** -40 °C up to +200 °C
- **Certification:** 2.1 2.2 3.1 MTC<sup>b</sup> MPI<sup>a</sup> CE IIB
- **Article code:** scan QR code to see article codes
- **Note:** for use of this component in a wire rope sling the safety factor must be 5 : 1, see the table on page 84

UMTS

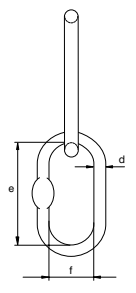
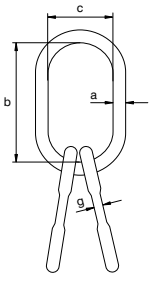

diameter	diameter chain 3/4 legs		working load limit	length inside	width inside	diameter	length inside	width inside	thickness	weight each
	$\beta \leq 45^\circ$	$45^\circ < \beta \leq 60^\circ$								
a mm	mm	mm	t	b mm	c mm	d mm	e mm	f mm	g mm	kg
18	6	6	3.65	135	75	16	120	70	7	1.97
22	8	8/10	6.8	170	90	18	135	75	9	3.30
28	10	13	11	209	120	20	150	82	11	5.40
36	13	16	17.7	270	145	25	190	103	14	11.2
38	16	18/19	21.2	250	150	30	235	125	17	15.1
50	20	22	41.6	380	200	38	250	150	22	32.2

CAD



UMSW

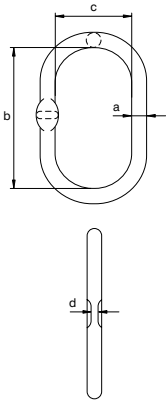

## Green Pin® Wider Master Link GR10

### Grade 10 wider master link

- **Material:** alloy steel, grade 10, quenched and tempered
- **Safety factor:** MBL equals 5 x WLL
- **Standard:** follows the EN1677 with values for grade 10 and conforms to ASTM A952/A952M and ASME B30.9
- **Finish:** painted blue
- **Temperature range:** -40 °C up to +200 °C
- **Certification:** 2.1 2.2 3.1 MTC<sup>®</sup> MPI<sup>®</sup> CE IIB
- **Article code:** scan QR code to see article codes

Scan for additional product details



working load limit	diameter	length inside	width inside	thickness	weight each
t	a mm	b mm	c mm	d mm	kg
4.1	17	160	90	9	0.85
6.7	19	160	90	9	1.08
11.5	25	210	115	13	2.43
17	33	270	140	17	5.40
27.7	38	275	150	21	7.50
45	50	380	200	50	17.7
64	56	400	200	56	23.5

CAD



# Green Pin® Wider Master Link Assembly GR10

## Grade 10 wider master link assembly

Scan for additional product details



- **Material:** alloy steel, grade 10, quenched and tempered
- **Safety factor:** MBL equals 5 x WLL
- **Standard:** follows the EN1677 with values for grade 10 and conforms to ASTM A952/A952M and ASME B30.9
- **Finish:** painted blue
- **Temperature range:** -40 °C up to +200 °C
- **Certification:** 2.1 2.2 3.1 MTC<sup>b</sup> MPI<sup>a</sup> CE IIB
- **Article code:** scan QR code to see article codes

UMTSW

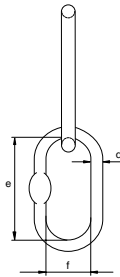
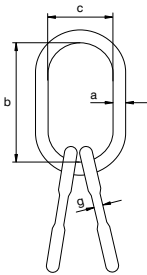

working load limit	diameter	length inside	width inside	diameter	length inside	width inside	thickness	weight each
t	a mm	b mm	c mm	d mm	e mm	f mm	g mm	kg
4.3	19	160	90	14	120	70	9	1.96
6.7	23	180	100	17	160	90	9	3.50
28.1	40	300	160	33	270	140	17	19.8
38.3	45	340	180	38	275	150	21	27.8
75	60	400	200	50	380	200	50	62.5

CAD

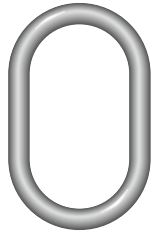

P-6810

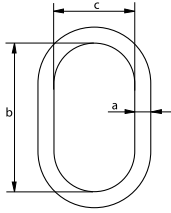

# Green Pin® DNV Master Link

## Grade 8 master link

- **Material:** alloy steel, grade 8
- **Safety Factor:** MBL equals 5 x WLL
- **Standard:** DNV 2.7-1, EN 12079-2 and EN 1677-4
- **Finish:** painted silver
- **Temperature range:** -40 °C up to +200 °C
- **Certification:** 2.1 2.2 3.1 MTC<sup>®</sup> MPI<sup>®</sup> DNV 2.7-1<sup>a</sup> CE IIB
- **Article code:** scan QR code to see article codes
- **Note:** size WLL 75 t and 100 t have a temperature range of -20 °C up to +200 °C

Scan for additional product details



working load limit	diameter	length inside	width inside	weight each
t	a mm	b mm	c mm	kg
4.1	16	150	75	0.68
7	22	270	140	2.28
9.3	26	270	140	3.11
14.5	28	270	140	3.78
19.5	28	200	110	3
19	32	270	140	5.02
26	36	270	140	6.46
30.5	40	280	155	8.46
45	45	320	175	12.2
51	50	350	195	16.5
75	65	410	220	33
100	75	450	250	49

CAD INFO





# Green Pin® DNV Master Link Assembly

## Grade 8 master link assembly

Scan for additional product details

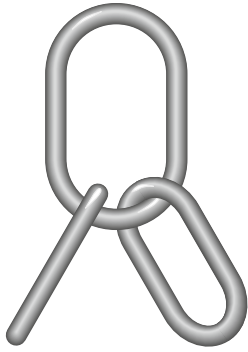
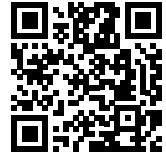

P-6820

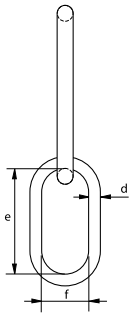
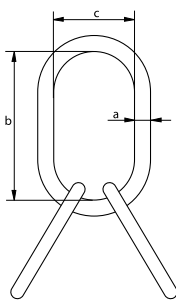

- **Material:** alloy steel, grade 8
- **Safety Factor:** MBL equals 5 x WLL
- **Standard:** DNV 2.7-1, EN 12079-2 and EN 1677-4
- **Finish:** painted silver
- **Temperature range:** -40 °C up to +200 °C
- **Certification:** 2.1 2.2 3.1 MTC<sup>b</sup> MPI<sup>b</sup> DNV 2.7-1<sup>a</sup> CE IIB
- **Article code:** scan QR code to see article codes
- **Note:** size WLL 75 t and 100 t have a temperature range of -20 °C up to +200 °C

working load limit	diameter	length inside	width inside	diameter	length inside	width inside	weight each
t	a mm	b mm	c mm	d mm	e mm	f mm	kg
4.1	16	150	75	14.5	125	60	1.62
7	22	270	140	22	162	90	5.22
9.3	26	270	140	22	162	90	6.05
14.5	28	270	140	22	162	90	6.73
19	32	270	140	28	200	110	10.9
26	36	270	140	28	200	110	12.4
30.5	40	280	155	32	270	140	18.5
40	45	320	175	36	270	140	25.1
51	50	350	195	45	320	175	40.9
75	65	410	220	50	350	195	66.1
100	75	450	250	65	410	220	115

CAD INFO





P-6815

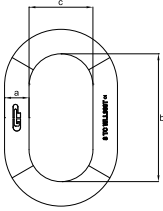

## Green Pin® Heavy Duty Master Link

### Grade 8 weldless heavy duty master link

- **Material:** alloy steel, grade 8
- **Safety Factor:** MBL equals 5 x WLL
- **Standard:** ASME B30.26
- **Finish:** painted silver and green
- **Temperature range:** -40 °C up to +200 °C
- **Certification:** 2.1 2.2 3.1 MTC<sup>a</sup> MPI<sup>b</sup> US<sup>b</sup> CE IIA
- **Article code:** scan QR code to see article codes

Scan for additional product details



working load limit	diameter	length inside	width inside	weight each
t	a mm	b mm	c mm	kg
131	90	460	300	77
157	100	500	300	102
250	115	600	400	164
300	115	600	300	155
400	115	490	250	132

CAD

## LIFTING SLING FITTINGS FOR WIRE ROPE

# THIMBLES



### Applications

Thimbles are used to protect steel wire rope, fibre rope or synthetic rope. They are available in various models and sizes. All indicated types of thimbles in this catalogue can be used in combination with the above mentioned types of ropes.

More information about the range, certification and finish, please go to the introduction of chapter 3 lifting slings.

### Design

Royal Van Beest offers different type of thimble designs:

- Thimbles generally to DIN 6899, DIN 3090, EN 13411-1, US Federal Specification FF-T-276b type III;
- Thimbles according to DIN 3091;
- Standard commercial thimbles;
- Heavy duty stub-end thimbles;
- Penant line type;
- Tubular type.

These type of thimbles can be cold-rolled, hot-rolled or die cast depending on the specific type of thimble.

### Instructions for use

Thimbles must be regularly inspected in accordance with the standards given in the country of use. This is required because the products in use may be affected by wear, misuse, overloading which may lead to deformation and/or alteration of the steel structure.

Make sure that the (wire) rope fits properly into the groove of the thimble you use. The nominal size of the thimble represents the diameter of the (wire) rope for which it is intended to be used. If there is no thimble available with a nominal size that meets the size of your (wire) rope, the next larger size of thimble must be used.

Before use, check if the thimble is free from impurities, sharp edges, cracks or other irregularities which may damage the wire rope and therefore affect the performance of the wire rope.



E-6110

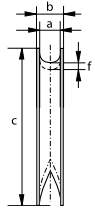
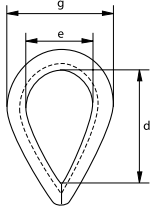

## Thimbles

### Standard commercial

- **Material:** mild steel
- **Finish:** electro-galvanized
- **Certification:** 2.1 CE IIB

diameter rope	width groove	width overall	length	length inside	width inside	thickness back	width	weight per 100 pcs
mm	a mm	b mm	c mm	d mm	e mm	f mm	g mm	kg
4	4	7	25	16	11	2.5	19	0.50
5	5	8	31	22	16	3	25	0.80
6	6	10	37	26	19	3.5	30	1.40
8	8	12	51	34	24	5	38	2.80
9	9	13	57	38	29	5.5	44	3
10	10	16	64	42	32	5.5	49	4.80
12	12	18	76	51	38	6.5	57	8
14	14	20	82	57	40	8	62	10
16	16	22	89	60	42	9	66	15
18	18	26	102	67	45	10	73	22
20	20	28	115	76	51	11	81	25
22	22	30	127	83	54	12.5	87	32
24	24	32	138	90	64	14	100	46
26	26	36	152	102	68	14.5	107	66
28	28	38	165	110	73	16	115	77
30	30	42	178	120	79	17	125	80
32	32	44	203	143	93	18	141	130



G-6120

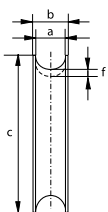
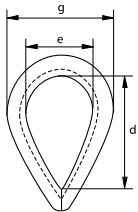

## Thimbles

### Heavy duty stub-end

- **Material:** mild steel
- **Finish:** hot dipped galvanized
- **Certification:** 2.1 CE IIB

diameter rope	width groove	width overall	length	length inside	width inside	thickness back	width	weight per 100 pcs
mm	a mm	b mm	c mm	d mm	e mm	f mm	g mm	kg
8	9	13	51	35	22	4	44	0.50
10	11	15	64	47	30	4	54	0.80
12	13	18	76	57	35	5	62	1.40
14	15	21	89	65	45	6	76	2.80
16	18	22	102	75	50	6	83	3
18	20	28	114	85	53	7	91	4.80
20	22	30	127	94	60	8	102	8
22	24	31	140	107	65	9	110	10
24	26	34	152	114	70	9.5	118	15
28	30	39	178	130	80	10	134	22
32	34	41	203	157	100	10	162	25
36	38	48	229	175	115	11	182	32
40	42	51	254	198	120	12	188	46
44	46	62	280	214	130	14	210	66
50	53	65	305	220	140	18	248	77
56	57	68	356	245	150	23	262	80
64	67	85	407	286	185	20	280	130

# C

## Thimbles

### Heavy duty stub-end reinforced with welded fillet plate



G-6128

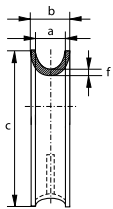
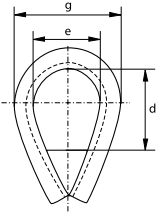

- **Material:** mild steel
- **Finish:** hot dipped galvanized reinforced with a welded fillet plate
- **Certification:** 2.1 CE IIB

width groove	width overall	length	length inside	width inside	thickness back	width	weight per piece
a mm	b mm	c mm	d mm	e mm	f mm	g mm	kg
35	55	220	100	80	10	150	3.20
40	65	245	120	90	12	160	5.10
50	80	290	125	110	16	200	9.20
62	100	360	160	140	20	250	17.4
72	115	390	175	160	20	265	19.4
85	125	470	245	190	20	300	29
100	150	540	290	200	25	370	39
115	165	570	300	210	25	380	52

For shackle

group	width groove								
	a mm								
	35	40	50	62	72	85	100	115	
G-4161	17, 25	25	35, 42.5	55	85				
G-4163	17, 25	25	35, 42.5	55	85				
G-4151	17, 25	25	35, 42.5	55	85				
G-4153	17, 25	25	35, 42.5	55	85				
P-6036						120, 150	150, 200		
G-6038						120, 150	150, 200		
P-6033	30	30	40, 55	75	125	125			
G-5263	30, 40	40		85	120	150, 175	175		
G-5163	17, 25	25	35, 42.5	55	85				
P-6031						120, 150	150, 200		
G-4263	4.75 ~ 25	6.5 ~ 25	9.5 ~ 30	16 ~ 55	25 ~ 75	30 ~ 75	55, 75	75	
P-5363	17, 25	25	35, 42.5	55	85				
P-5365	17, 25	25	35, 42.5	55	85	120, 150	150, 200		
P-5367	17, 25	25	35, 42.5	55	85	120, 150	150		
G-4164	17, 25	25							
G-4154	17, 25	25							
G-4169	17								
G-4159	17								



E-6131  
G-6131

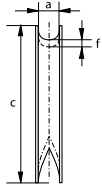
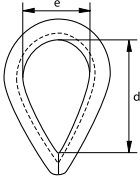

## Thimbles

Generally to DIN 6899 (B)

- **Material:** mild steel
- **Standard:** generally to DIN 6899 (B)
- **Finish:** thimbles for rope diameters up to and including 6 mm are electro-galvanized, other diameters are hot dipped galvanized
- **Certification:** 2.1 CE IIB

diameter rope	width groove	length	length inside	width inside	thickness back	weight per 100 pcs
mm	a mm	c mm	d mm	e mm	f mm	kg
2.5	3	22	19	12	1.6	0.60
3.5	4	26	21	13	1.6	0.80
4	5	32	23	14	1.9	1
5	6	38	25	16	2.4	2
6	7	44	28	18	2.4	2
7	8	51	32	20	2.8	2.70
9	10	57	38	24	3.1	4.10
11	12	64	45	28	3.3	6.90
13	13	70	48	30	3.3	7.20
13	14	76	51	32	3.7	10.2
15	16	83	58	36	3.8	16.4
16	17	89	61	38	4.7	19
17	18	95	64	40	4.7	20.3
18	20	102	72	45	5.7	27.3
20	22	114	80	50	5.7	30.8
22	24	127	90	56	6.5	44.8
24	26	140	99	62	6.8	59.2
26	28	152	112	70	8	72
28	30	165	120	75	8	104
30	32	178	128	80	8	115
32	34	203	152	95	8.5	153
34	36	216	160	100	8.5	176
36	38	229	176	110	8.5	176
38	40	241	184	115	10.5	292
40	42	254	192	120	10.5	320
42	45	305	240	150	10.5	364

C



S-6134

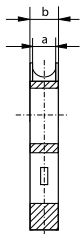
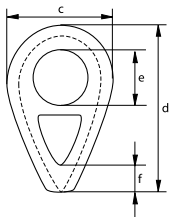

## Thimbles

According to DIN 3091

- **Material:** cast mild steel, (GTW 40)
- **Standard:** according to DIN 3091
- **Finish:** self-coloured
- **Certification:** 2.1 CE II B
- **Note:** the diameter (e) of the thimble for diameter wire rope 72 mm is 140 mm

diameter rope	width groove	width overall	width	length	diameter	length	weight per 100 pcs
mm	a mm	b mm	c mm	d mm	e mm	f mm	kg
8	9	15	40	56	14	-	18
10	11	17.5	50	70	18	-	32
12	13	20	60	84	21	-	52
14	16	23.5	70	98	25	-	80
16	18	26	80	130	28	16	90
18	20	28.5	90	145	31	18	121
20	22	31	100	161	35	20	161
22	24	33.5	110	177	38	22	211
24	26	36	120	193	41	24	271
26	29	39.5	130	209	44	26	355
28	31	42	140	224	47	28	420
32	35	47	160	256	53	32	630
36	40	53	180	288	59	36	884
40	44	58	200	320	65	40	1100
44	48	63	220	352	70	44	1500
48	53	69	240	384	76	48	2000
52	57	74	260	416	81	52	2500
56	62	80	280	448	86	56	3200
64	70	90	320	512	95	64	4600
72	79	101	360	576	140	72	6600



E-6135  
G-6135

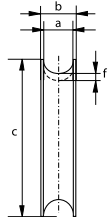
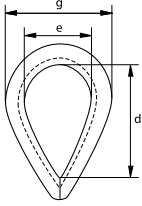

## Thimbles

Generally to DIN 3090

- **Material:** mild steel
- **Standard:** generally to DIN 3090
- **Finish:** for diameter 4 and 6 mm electro-galvanized  
other diameters hot dipped galvanized
- **Certification:** 2.1 CE II B

diameter wire rope	width groove	width overall	length	length inside	width inside	thickness back	width	weight per 100 pcs
mm	a	b	c	d	e	f	g	kg
4	5	8	35	20	10	2.1	25	1.40
6	7	10	50	30	15	2.6	33	3
8	9	13	68	40	20	4	43	7.10
10	11	15	77	50	25	5	47	17
12	13	19	100	60	30	6	63	24
14	16	22	110	70	35	8	70	31
16	18	25	125	80	40	8	80	50
18	20	27	142	90	45	9	90	62
20	22	30	155	100	50	10	102	90
22	24	33	165	110	55	10	107	100
24	26	35	180	120	60	10	120	130
26	29	36	190	130	65	12	122	220
28	31	37	197	140	70	12	128	240
32	35	43	225	160	80	15	145	216
36	40	60	250	180	90	15	170	430
40	44	66	290	200	100	20	190	570
44	48	72	315	220	110	20	205	850
48	53	77	350	240	120	20	220	1120
52	57	88	380	260	130	25	235	1530
56	62	95	405	280	140	25	270	2148
60	66	105	430	300	150	25	285	2300
64	70	110	485	320	160	30	310	3500

C

# Thimbles

Generally to EN 13411-1

- **Material:** mild steel
- **Standard:** generally to EN 13411-1 formerly BS 464
- **Finish:** hot dipped galvanized
- **Certification:** 2.1 CE IIB



G-6170

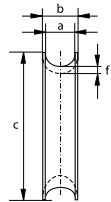
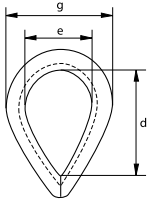

diameter rope		width groove	width overall	length	length inside	width inside	thickness back	width	weight per 100 pcs
inch	mm	a mm	b mm	c mm	d mm	e mm	f mm	g mm	kg
<sup>3</sup> / <sub>16</sub>	5	6	9.5	47	27	18	3	32	3.50
<sup>1</sup> / <sub>4</sub>	7	7	11	51	33	20.5	3.5	36	2.80
<sup>5</sup> / <sub>16</sub>	8	8	12.7	52	33	22	4	38	5.70
<sup>3</sup> / <sub>8</sub>	10	10	14.3	64	38	25	6.3	47.6	8
<sup>7</sup> / <sub>16</sub>	11	13	17.5	73	41	29	7.9	52	14.2
<sup>1</sup> / <sub>2</sub>	13	14	20.6	79	45	32	7.9	58.8	18
<sup>9</sup> / <sub>16</sub>	14	15	20.6	88	56	38	7.9	64	18.9
<sup>5</sup> / <sub>8</sub>	16	16	22.2	96	59	41	8.7	74.5	22.4
<sup>11</sup> / <sub>16</sub>	17	19	28.6	108	67	45	9.5	79.4	39.7
<sup>3</sup> / <sub>4</sub>	19	21	28.6	124	73	51	11.1	92	45.6
<sup>7</sup> / <sub>8</sub>	22	22	31.7	131	83	56	12.7	102	61.5
<sup>15</sup> / <sub>16</sub>	24	25	33.4	146	92	64	12.7	110	106
1	25	27	35	162	108	70	14.3	119	97.3
1 <sup>1</sup> / <sub>8</sub>	29	29	38	178	112	76	15.9	133	151
1 <sup>1</sup> / <sub>4</sub>	32	33	41.3	197	133	95	15.9	152	204
1 <sup>3</sup> / <sub>8</sub>	35	38	47.6	228	152	105	19	175	318
1 <sup>1</sup> / <sub>2</sub>	38	41	52	254	165	114	23.8	197	363
1 <sup>5</sup> / <sub>8</sub>	41	47	57	280	188	120	24	205	499
1 <sup>3</sup> / <sub>4</sub>	44	51	57	286	178	127	25.4	228	556
1 <sup>7</sup> / <sub>8</sub>	48	60	66.6	317	190	133	28.6	248	-
2	51	64	69.8	330	203	140	30.1	257	-
2 <sup>1</sup> / <sub>8</sub>	54	64	69.8	330	203	140	30.1	257	-
2 <sup>1</sup> / <sub>4</sub>	57	67	76.2	356	246	160	31.7	296	-
2 <sup>1</sup> / <sub>2</sub>	64	75	93	420	255	170	43	300	-



G-6142

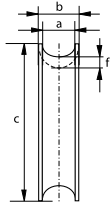
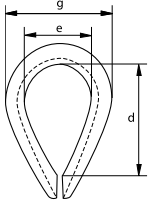

## Thimbles

Generally to US Fed. Spec. FF-T-276b type III

- **Material:** mild steel
- **Standard:** generally to US Federal Specification FF-T-276b type III and generally to EN 13411-1
- **Finish:** hot dipped galvanized
- **Certification:** 2.1 CE IIB

diameter rope	width groove	width overall	length	length inside	width inside	thickness back	width	weight per 100 pcs
mm	a mm	b mm	c mm	d mm	e mm	f mm	g mm	kg
6	7	10	56	41	22	1.5	38	2.70
8	8	12.6	64	48	27	2	46	5.10
9	10	17.2	73	54	26	2.5	54	9.10
11	12	18	83	60	32	3	60	13.9
13	13.6	21.4	92	70	38	4	70	19.9
14	15	23	92	70	38	4	68	20.5
16	16.8	24.5	103	83	44	4	78	29.8
19	19.8	31.8	127	95	51	6	97	60.8
22	24	36	140	108	57	6	108	80.4
25	27	39	156	114	63	6	125	109
28 - 32	34	46	178	130	73	6	148	147
32 - 35	36	56	228	165	89	10	173	366
35 - 38	39	63	228	158	89	12	181	478
41	42	66	285	203	101	12	206	731
45	45	69	309	228	114	12	216	778
48 - 51	54	78	380	305	152	12	250	1150
57	60	92	435	356	178	16	301	1935
64	70	110	465	360	178	20	310	2640
76	85	125	550	410	180	20	330	3850



G-6151

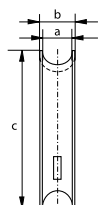
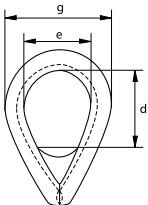

## Thimbles

Pennant line type

- **Material:** mild steel
- **Finish:** hot dipped galvanized produced with a welded fillet plate
- **Certification:** 2.1 CE IIB

diameter wire rope	width groove	width overall	length	length inside	width inside	width	weight each
mm	a mm	b mm	c mm	d mm	e mm	g mm	kg
16	17	22	102	50	50	75	0.40
18	19	25	114	50	53	85	0.50
20	21	29	127	60	60	100	0.80
22	23	33	140	60	65	110	0.90
24	25	34	152	70	70	115	1
28	30	38	178	75	80	135	1.70
30	33	44	203	80	100	155	2.50
36	38	49	229	110	115	175	4
40	41	52	254	120	120	190	4.50
44	46	60	279	120	130	210	7
50	52	65	305	140	145	245	8.30
56	60	72	356	155	155	260	12.5
64	70	84	432	200	190	310	19.5
76	81	119	483	235	230	350	29
82	92	130	559	240	255	395	35
90	105	145	610	275	280	430	42
120	120	155	660	295	285	450	58

C

## Thimbles

Tubular type

- Material: mild steel
- Finish: painted
- Certification: 2.1 CE IIB



P-6190

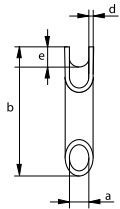

diameter wire rope	diameter	length	width inside	thickness	height	weight each
mm	a mm	b mm	c mm	d mm	e mm	kg
10	12	90	23	4	8	0.23
12	15	105	27	5	10	0.40
14	17	115	27	5	10	0.50
16	19	120	32	5	12	0.60
18	22	140	35	5	15	0.75
22	25	180	45	6	16	1.40
24	28	180	45	7	16	1.75
26	30	195	47	7	18	2
32	35	215	60	7	22	2.50
38	45	260	70	7	27	3.50
44	50	280	75	7	28	4.20

C

## Thimbles

Tubular type with welded plate

- Material: mild steel
- Finish: painted
- Certification: 2.1 CE IIB



P-6195

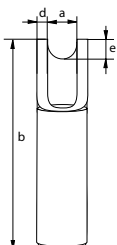
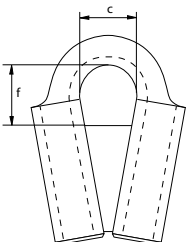

diameter wire rope	width groove	length	width inside	thickness	height	length inside	weight each
mm	a mm	b mm	c mm	d mm	e mm	f mm	kg
10	12	84	23	4	8	24	0.26
12	15	95	27	5	10	31	0.42
14	17	100	27	5	10	38	0.48
16	19	112	32	5	12	46	0.61
18	22	125	35	5	15	47	0.95
22	25	150	45	6	16	61	1.33
24	28	157	45	7	16	56	1.67
26	30	170	47	7	18	68	1.96
32	35	190	60	7	22	73	2.43
36	40	212	70	9	26	80	4.32
38	45	228	70	7	27	94	3.67

## LIFTING SLING FITTINGS FOR WIRE ROPE

# WIRE ROPE CLIPS



## Applications

Wire rope clips are used on wire rope eye-loop connections and on complete loops. They are used in end-to-end connections where socketing or splicing is not feasible and when a temporary joint is required.

More information about the range, certification and finish, please go to the introduction of chapter 3 lifting slings.

## Design

Green Pin® wire rope clips are drop forged and have a bridge with grooves to tighten the wire rope properly in the clip; the DIN wire rope clips have a malleable base, without grooves.

Wire rope clips are generally marked with:

- manufacturer's symbol - e.g. GP
- wire rope diameter in mm or inches - e.g. 13 or 1/2"
- traceability code - e.g. A1

## Instructions for use

Wire rope clips should be inspected before use to ensure that:

- all markings are legible;
- a wire rope clip with the correct dimensions has been selected;
- the nuts or any other locking system cannot vibrate out of position;
- the wire rope clip is free from nicks, gouges and cracks;

Never modify, repair or reshape a wire rope clip by machining, welding, heating or bending as this may affect their performance.

The wire rope clip should be fitted to the wire rope as shown in below figures. The bridge of the wire rope clip should always be placed on the load bearing part of the rope. The U-bolt of the clip should be placed on the rope tail, also known as the dead end of the rope. Turn back enough wire rope length so that the required minimum number of clips can be installed according to the instructions below.

The first clip must be placed one bridge width from the turned-back rope tail or dead end of the rope, according to figure 1. Tighten the nuts to the specified torque.

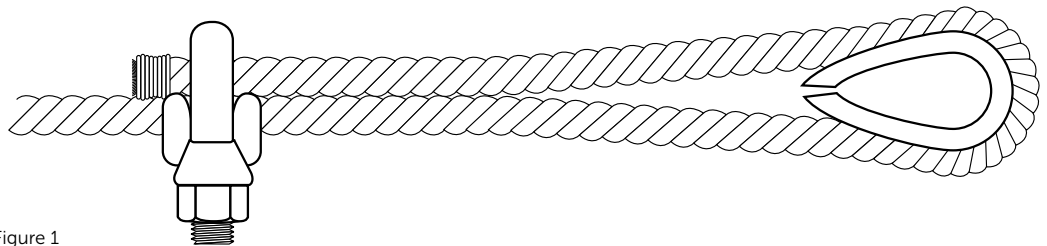

Figure 1

The second clip must be placed immediately against the thimble. Take care that the correct tightening of the clip does not damage the outer wires of the wire rope (figure 2). Tighten the nuts firmly but not yet to the specified torque.

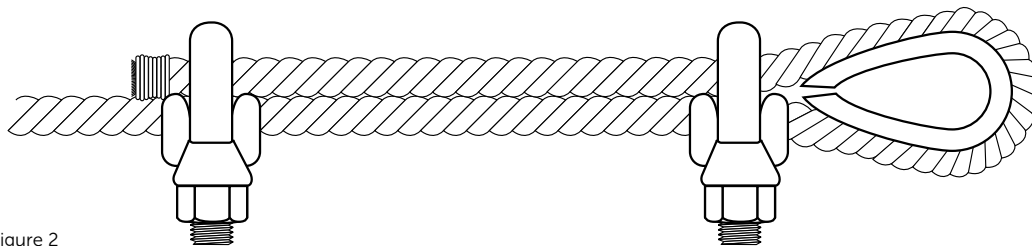

Figure 2

The following clips should be placed on the wire rope between the first and second clip in such a way that they are separated by at least 1½ times the clip-width with a maximum of 3 times the clip-width, according to figure 3.

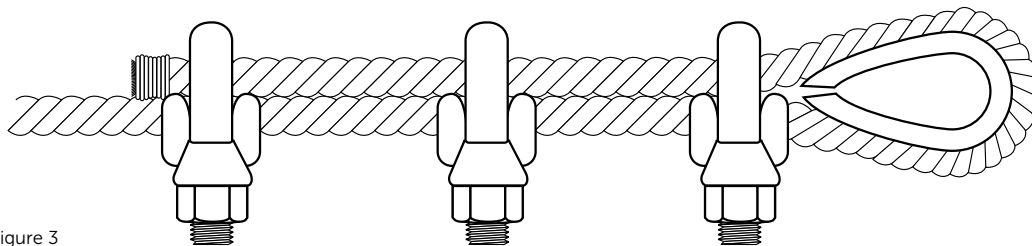

Figure 3

Apply light tension on the rope and tighten all nuts evenly, alternating until reaching the specified torque. After assembly and before the rope is taken into service, the nuts must be tightened further to the prescribed torque. After the load has been applied to the assembly for the first time, the torque value must be checked and corrected if necessary. Re-tightening of the nuts must be done at 10.000 cycles (heavy usage), 20.000 cycles (moderate usage) or 50.000 cycles (light usage). If cycles are unknown, a competent person could fix a time period, e.g. every 3 months, 6 months, annually.

The torque values and the minimum number of clips to be applied for a particular rope size are given in the following tables.

diameter wire rope	diameter wire rope	min. no of clips required	length of rope to turn back	torque value	torque value
inch	mm		mm	Nm	Ft.Lbs
1/8	3 - 4	2	85	6.1	4.5
3/16	5	2	95	10.2	7.5
1/4	6 - 7	2	120	20.3	15
5/16	8	3	133	40.7	30
3/8	9 - 10	3	165	61	45
7/16	11	3	178	88	65
1/2	12 - 13	3	292	88	65
9/16	14 - 15	3	305	129	95
5/8	16	3	305	129	95
3/4	18 - 20	4	460	176	130
7/8	22	4	480	305	225
1	24 - 26	5	660	305	225
1 1/8	28 - 30	6	860	305	225
1 1/4	32 - 34	7	1120	488	360
1 3/8	36	7	1120	488	360
1 1/2	38 - 40	8	1370	488	360
1 5/8	41 - 42	8	1470	583	430
1 3/4	44 - 46	8	1550	800	590
2	48 - 52	8	1800	1017	750
2 1/4	56 - 58	8	1850	1017	750
2 1/2	62 - 65	9	2130	1017	750
2 3/4	68 - 72	10	2540	1017	750
3	75 - 78	10	2690	1627	1200

Table 1, Green Pin® wire rope clips generally to EN 13411-5 Type B, required number and torque value

diameter wire rope	min. no of clips required	torque value	torque value
mm		Nm	Ft.Lbs
5	3	2	1.5
6.5	3	3.5	2.6
8	4	6	4.4
10	4	9	6.6
12	4	20	14.8
13	4	33	24.3
14	4	33	24.3
16	4	49	36
19	5	68	50
22	5	107	79
26	5	147	108
30	6	212	156
34	6	296	218
40	6	363	268

Table 2, Wire rope clips generally to EN 13411-5 Type A, required number and torque value

The efficiency of a wire rope termination made with wire rope clips depends on the correct placement of the clips on the rope and on correct fitting and tightening of the clips. With inadequately tightened nuts or with an insufficient number of wire rope clips the rope end may slide through the clips during use.

The fitting of the clips on the ropes may be affected by various circumstances, such as:

- the nut may be tight on the thread, yet not tight against the bridge;
- contamination of the thread by dirt, oil or corrosion products, which may prevent correct tightening of the nut.

Forged wire rope clips provide greater bearing surface and more consistent strength than malleable cast iron clips.

Suitable applications of wire rope clips to EN 13411-5 standards include suspending static loads and single use lifting operations which have been assessed by a competent person taking into account appropriate safety factors.

Wire rope clips should not be used in following applications:

- hoist ropes in mines;
- rope drives for cranes in steel works and rolling mills;
- permanent fastening of ropes in other rope drives;
- rope terminations for load suspension devices in the operation of lifting appliances, except in the case of lifting tackles where these are produced for a special application and used only once.

Wire rope clips must be regularly inspected in accordance with the safety standards given in the country of use. This is required because the products in use may be affected by wear, misuse, overloading etc. which may lead to deformation and alteration of the material structure. Inspection should take place at least every six months (follow the local rules in the country of use) and more frequently when the products are used in severe operating conditions.



# Green Pin® Wire Rope Clip

## Wire rope clip generally to EN 13411-5 Type B

Scan for additional product details

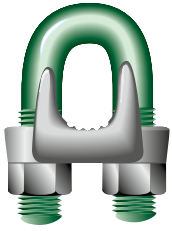

- **Material:** bridge: drop forged high tensile steel SAE 1045  
U-bolt: SAE 1015
- **Standard:** EN 13411-5 Type B  
formerly U.S. Federal Specification FF-C-450D
- **Finish:** hot dipped galvanized  
U-bolt and/or nuts for diameter bow 5, 6, 8 and 10 are electro-galvanized
- **Certification:** 2.1 2.2 CE IIB
- **Article code:** scan QR code to see article codes

G-6240

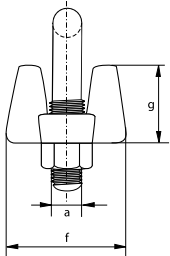
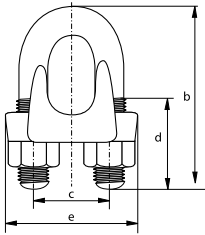

diameter wire rope	diameter	length bow	width inside	length thread	length base	thickness base	height base	weight per 100 pcs
mm	a mm	b mm	c mm	d mm	e mm	f mm	g mm	kg
3 - 4	5	24	12	11	24	21	10	3
5	6	31	15	13	29	24	13	7
6 - 7	8	34	19	13	37	30	18	8.40
8	10	45	22	19	43	33	19	12.4
9 - 10	11	49	26	19	49	42	25	21
11	12	60	30	25	58	46	26	33.2
12 - 13	13	61	30	25	58	48	31	33.1
14 - 15	14	72	33	32	63	52	31	45.6
16	14	74	33	32	64	54	36	45.8
18 - 20	16	86	38	37	72	57	38	64.3
22	19	98	45	41	80	62	40	96.4
24 - 26	19	108	48	46	88	67	47	115
28 - 30	19	117	51	51	91	73	48	127
32 - 34	22	130	59	54	105	79	56	197
36	22	140	60	59	108	79	58	206
38 - 40	22	147	66	60	112	85	64	254
41 - 42	25	161	70	67	121	92	67	322
44 - 46	29	174	78	70	134	97	76	418
48 - 52	32	195	86	78	150	113	85	602
56 - 58	32	213	98	81	162	116	100	776
62 - 65	32	227	105	87	168	119	113	862
68 - 72	32	243	112	91	174	127	124	1015
75 - 78	38	271	121	98	194	135	136	1272

C



E-6260

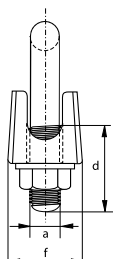
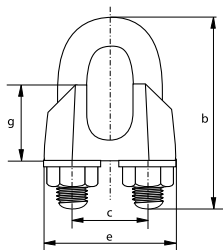

## Wire Rope Clip

Generally to EN 13411-5 Type A

- **Material:** bridge: malleable steel  
U-bolt: mild steel
- **Standard:** EN 13411-5 Type A  
formerly DIN 1142
- **Finish:** electro-galvanized
- **Certification:** 2.1 CE II B

diameter wire rope	diameter	length bow	width inside	length thread	length base	thickness base	height base	weight per 100 pcs
mm	a mm	b mm	c mm	d mm	e mm	f mm	g mm	kg
5	5	25	12	14	25	13	13	2.30
6.5	6	32	14	17	30	16	14	3.90
8	8	41	18	20	39	20	18	8.40
10	8	46	20	24	40	20	21	8.40
12	10	56	24	28	50	25	24	17
13	12	64	29	29	55	28	29	26.1
14	12	66	28	31	59	30	28	28.6
16	14	76	34	35	64	32	35	42
19	14	83	37	36	68	33	40	49
22	16	96	41	40	74	34	44	67
26	20	111	46	50	84	38	51	111
30	20	127	54	55	95	41	59	140
34	22	141	60	60	105	45	67	202
40	24	159	68	65	117	49	77	268

C

# Wire Rope Clip

Generally to DIN 741



E-6220

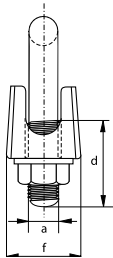
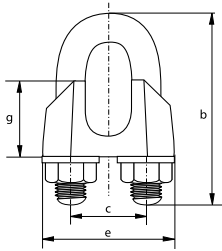

- **Material:** bridge: cast  
U-bolt: mild steel
- **Standard:** formerly DIN 741
- **Finish:** electro-galvanized
- **Certification:** 2.1 CE IIB

diameter wire rope	diameter	length bow	width inside	length thread	length base	thickness base	height base	weight per 100 pcs
mm	a mm	b mm	c mm	d mm	e mm	f mm	g mm	kg
3	4	20	9	12	21	10	10	1
5	5	24	11	13	23	11	10	1.40
6	5	28	13	15	26	12	11	1.60
8	6	34	16	19	30	14	15	3.30
10	8	42	19	22	34	18	17	6
11	8	44	20	22	36	19	18	7
13	10	55	24	30	42	23	21	11.8
14	10	57	25	30	44	23	22	12.4
16	12	63	29	33	50	26	26	19
19	12	75	32	38	54	29	30	23.6
22	14	85	37	44	61	33	34	36.6
26	14	95	41	45	65	35	37	41
30	16	110	48	50	74	37	43	62
34	16	120	52	55	80	42	50	74.4
40	16	140	58	60	88	45	55	108
45	18	163	65	75	97	49	60	134
50	20	170	72	77	106	51	65	174

## LIFTING SLING FITTINGS FOR WIRE ROPE

# SLEEVES



### Applications

Sleeves are used to create loop ends on wire rope slings. They are available in two types and in various sizes.

### Design

Aluminium wire rope sleeves are manufactured according to EN 13411-3. For safety during fabrication and application they are of seamless construction. Prescon carbon steel sleeves are manufactured from carbon steel. The sleeves are of seamless construction and fit industry standard dies.

### Instructions for use

For Aluminium sleeves, please refer to EN 13411-3. Prescon sleeves are recommended for use with 6 x 19 or 6 x 37 IPS or XIP (EIP), RRL, FC, or IWRC wire rope. After creating a loop end multiple progressive pressings are required to prevent flash, which will develop into a permanent mark or possibly a crack in the sleeve. A light oil lubricant should be applied to each die before pressing. The sleeve must be cleaned after the swaging operation to stimulate effective colour change. Colour change is not an indication for proper swaging, only an indication that the sleeve has been pressed. Proper swaging practices are the sling manufacturer's responsibility. Before using sleeves with other type lay, construction or grade of wire rope, it is recommended that the termination be proof loaded to prove the adequacy of the assembly. Regular inspection of the swaging machine, dies etc. must be conducted to ensure that the equipment continues to meet required standards.

C

## Prescon sleeves

For wire rope



S-6500

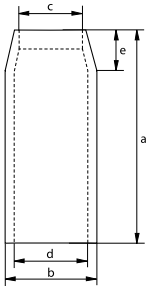

- **Material:** special carbon steel
- **Finish:** up to and including size 16 mm colour coded  
sizes above 16 mm self-coloured
- **Certification:** 2.1 CE IIB

diameter wire rope	length	diameter outside	diameter inside	diameter inside	length	diameter outside pressed	weight per 100 pcs
mm	a mm	b mm	c mm	d mm	e mm	mm	kg
6	25.4	16.7	8.3	11.9	7.1	12.7	2.15
8	38.1	23	11.1	15.5	11.1	18.5	6.50
10	38.1	23	11.9	16.7	11.1	18.5	5.50
11	51	31	14.3	21.4	15.1	24.9	11.3
13	51	31	15.9	23	15.1	24.9	12.5
14	70	37	17.5	26.2	17.9	30.5	19.5
16	70	37	19.1	27.8	17.9	30.5	25.9
19	81	43.6	23.4	32.5	21.8	35.8	39.9
22	90	51.6	26.2	38.9	25.4	41.4	62
25	102	58	29.4	43.7	28.6	47.8	85
28	122	64	32.5	49.2	31.8	53	118
32	132	71	36.5	55	35.7	58	154
34 - 35	148	76	39.7	60	39.7	62	195
37 - 38	159	83	42.9	66.7	42.9	67	227
44 - 45	184	102	49.2	79	50	77	367
50 - 52	216	111	57	92	57	89	510
56 - 57	243	128	64	102	64	103	862
62 - 64	267	140	70	114	71	113	1043
68 - 70	292	146	76	121	79	118	1270
75 - 76	305	152	83	127	86	124	1334
87 - 89	356	178	98	148	100	145	2105
93 - 95	381	191	103	160	108	156	2495
100 - 102	406	206	111	173	114	180	3130
112 - 114	457	232	124	194	129	187	4536



A-6550

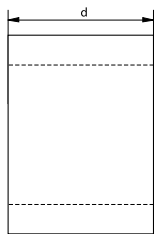
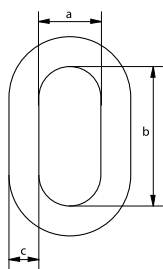

## Aluminium sleeves

For wire rope

- **Material:** aluminium
- **Standard:** EN 13411-3 formerly DIN 3093 A
- **Finish:** self-coloured
- **Certification:** 2.1 CE IIB

size	diameter	width	thickness	length	weight per 1000 pcs
	a mm	b mm	c mm	d mm	kg
1	1.2	2.4	0.65	5	0.10
1.5	1.7	3.4	0.75	6	0.21
2	2.2	4.4	0.85	7	0.24
2.5	2.7	5.4	1.05	9	0.50
3	3.3	6.6	1.25	11	0.84
3.5	3.8	7.6	1.5	13	1.32
4	4.4	8.8	1.7	14	2
4.5	4.9	9.8	1.9	16	2.61
5	5.5	11	2.1	18	5
6	6.6	13.2	2.5	21	5
6.5	7.2	14.4	2.7	23	7.55
7	7.8	15.6	2.9	25	9.53
8	8.8	17.6	3.3	28	15
9	9.9	19.8	3.7	32	19.8
10	10.9	21.8	4.1	35	25
11	12.1	24.2	4.5	39	35.8
12	13.2	26.4	4.9	42	45.8
13	14.2	28.4	5.4	46	59.7
14	15.3	30.6	5.8	49	73.5
16	17.5	35	6.7	56	111
18	19.6	39.2	7.6	63	159
20	21.7	43.4	8.4	70	220
22	24.3	48.6	9.2	77	280
24	26.4	52.8	10	84	376
26	28.5	57	10.9	91	481
28	31	62	11.7	98	603
30	33.1	66.2	12.5	105	735
32	35.2	70.4	13.4	112	897
34	37.8	75.6	14.2	119	1080
36	39.8	79.6	15	126	1275
38	41.9	83.8	15.8	133	1490
40	44	88	16.6	140	1734
42	46.2	92.4	17.5	147	1940
44	48.4	96.8	18.3	154	2314
46	50.6	101.2	19.2	161	2557
48	52.8	105.6	20	168	3010
50	55	110	20.8	175	3400
52	57.2	114.4	21.6	182	3813
54	59.4	118.8	22.5	189	4120
56	61.6	123.2	23.3	196	4772
58	63.8	127.6	24.2	203	5200
60	66	132	25	210	5880

EN 13411-3 Table A.2 - Ferrule size numbers

Rope diameter			Ferrule size number			
			Case 1	Case 2	Case 3	Case 4
Nominal d mm	Measured		single layer round strand ropes with FC and cable laid ropes  C* ≥ 0,283	single layer round strand ropes with IWRC and rotation-resistant round strand ropes  C* ≤ 0,487	single layer round strand ropes with IWRC, rotation- resistant ropes and parallel-closed ropes 0,487< C* ≤ 0,613	spiral strands 2 ferrules  C* ≤ 0,613
	from mm	to mm				
2.5	2.5	2.7	2.5	3	-	-
3	2.8	3.2	3	3.5	-	-
3.5	3.3	3.7	3.5	4	-	-
4	3.8	4.3	4	4.5	-	5
4.5	4.4	4.8	4.5	5	-	6
5	4.9	5.4	5	6	-	6.5
6	5.5	5.9	6	6.5	-	7
	6	6.4			7	
6.5	6.5	6.9	6.5	7	8	8
7	7	7.4	7	8	9	9
8	7.5	7.9	8	9	9	10
	8	8.4			10	
9	8.5	8.9	9	10	10	11
	9	9.5			11	
10	9.6	9.9	10	11	11	12
	10	10.5			12	
11	10.6	10.9	11	12	12	13
	11	11.6			13	
12	11.7	11.9	12	13	13	14
	12	12.6			14	
13	12.7	12.9	13	14	14	16
	13	13.7			16	
14	13.8	13.9	14	16	16	18
	14	14.7			18	
16	14.8	15.9	16	18	18	20
	16	16.8			20	
18	16.9	17.9	18	20	20	22
	18	18.9			22	
20	19	19.9	20	22	22	24
	20	21			24	
22	21.1	21.9	22	24	24	26
	22	23.1			26	
24	23.2	23.9	24	26	26	28
	24	25.2			28	
26	25.3	25.9	26	28	28	30
	26	27.3			30	
28	27.4	27.9	28	30	30	32
	28	29.4			32	
30	29.5	29.9	30	32	32	34
	30	31.5			34	
32	31.6	31.9	32	34	34	36
	32	33.6			36	
34	33.7	33.9	34	36	36	38
	34	35.7			38	
36	35.8	35.9	36	38	38	40
	36	37.8			40	
38	37.9	37.9	38	40	40	44
	38	39.9			44	
40	40	42	40	44	48	48
44	42.1	43.9	44	48	48	48
	44	46.2			52	
48	46.3	47.9	48	52	52	52
	48	50.4			56	
52	50.5	51.9	52	56	56	60
	52	54.6			60	
56	54.7	55.9	56	60	-	-
	56	58.8			-	
60	58.9	59.9	60	-	-	-
	60	63		-		

\* for metallic cross-sectional area factor C refer to EN 12385 parts 4, 5 & 10

# LIFTING SLING FITTINGS FOR WIRE ROPE

# SOCKETS



## Applications

Sockets are used as a connection to attach steel wire rope to a fixed point. This may be an anchoring system for tubes or pipes, anchor wires for dredging materials, anchor cables for oil platforms, fastening points for towing cables or for fastening cables in constructions such as bridges, roofs etc. Sockets are designed for in-line use only. Sockets are the strongest steel wire rope end fittings available. If they are assembled in the proper way they meet or exceed the breaking strength of the steel wire rope.

## Design

Green Pin® open- and closed spelter sockets and Green Pin® open wedge sockets are made from cast high tensile steel.

These sockets are generally marked with:

- manufacturer's symbol - e.g. GP
- wire rope diameter in mm and inches - e.g. 20-22 and 7/8"
- traceability code - e.g. A01
- socket number - e.g. 104

Swage sockets are drop forged from special bar quality carbon steel C-1035 and spheroidized annealed to make them suitable for cold swaging.

## Socket Lock Socketing Resin

To offer a complete assortment, Green Pin®'s parent company, Royal Van Beest, is the distributor of Socket Lock Socketing Resin. Socket Lock Socketing Resin is designed for speltering wire rope. Socket Lock is developed with a unique formula that uses polyester fibres to thicken the resin and provide a homogenous (consistent) resin cone throughout. Unlike traditional products, which use large grain silica to thicken the resin, the fibres of the innovative Socket Lock Socketing Resin will suspend within the mixed resin and provide a consistent resin cone from top to bottom. The consistency of the resin cone prevents the formation of surface cracking once the resin is hardened. The formula is developed to ensure the resin flows easily and can optimally penetrate the bottom of the socket. This will result in an excellent resin cone, providing the end user with a high-quality socket termination. Socket Lock Socketing Resin kits are now available from stock at Green Pin® and can be ordered in kit sizes of 250, 500, 1000 and 2000 cc.

Additionally, Green Pin® also has the Socket Lock Socketing Booster Pack available. The booster packs are used for cold temperature socketing and are required when ambient temperatures are below +16 °C (+60 °F). For instructions for use, please consult the Green Pin® website: [www.greenpin.com/socketlock](http://www.greenpin.com/socketlock).

## Instructions for use

### 1) Open spelter sockets – closed spelter sockets

In the past melted zinc was poured into the sockets to fix the steel wire rope; nowadays resins are used for this purpose.

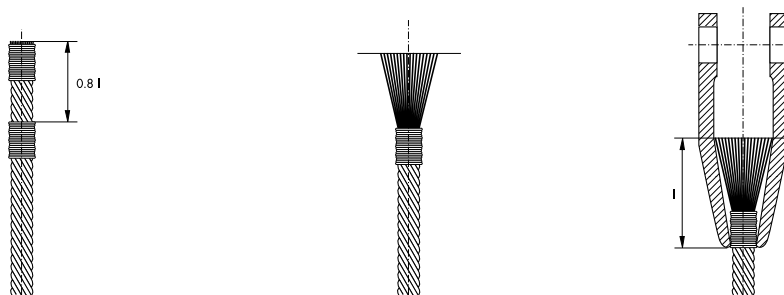

Figure 1

- brooming is done after the wire rope has been placed into the socket;
- when using resins always exactly follow the instructions given by the manufacturer carefully;
- socketing must be done by specialists in a certified sling shop.

### 2) Open wedge sockets

The wedge and body act as a vice which grips the wire rope and locks it in place. Green Pin® wedge sockets may be used within the range of wire rope diameters as shown in the table further on in the catalogue.

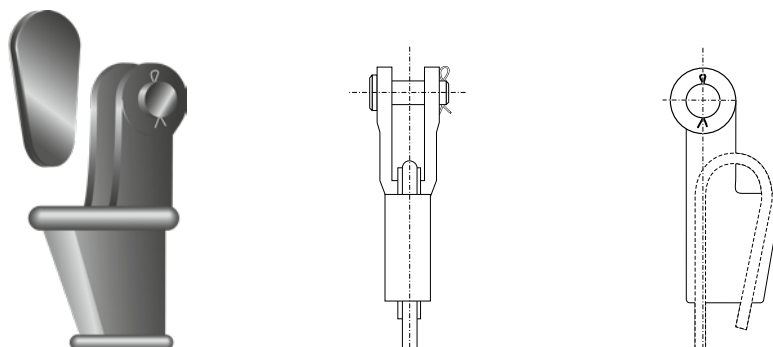

Figure 2

When using open wedge sockets the following precautions should be taken:

- before use always inspect the socket, the wedge and the pin;
- use only with standard 6-8 strand wire rope;
- in case of use with non-rotating wire rope there is a risk of core slippage or loss of rope lay. Instruction from the wire rope manufacturer must be followed to prevent this by; for example welding, brazing or seizing the dead end before introduction in the socket. The minimum tail length is 20 times the wire rope diameter. Furthermore, the wire rope construction must be checked for suitability of bending around the radius of the wedge. Additional measures might be necessary to prevent distortion;
- always be sure that socket and wedge have the correct size for the wire rope diameter;
- the loaded part of the steel wire rope should be mounted in the centre line of the pin;
- when installing the wire rope, always pre-load the wedge with the wire rope in place;
- never weld the tail; the tail should have a length of at least 6 times the wire rope diameter with a minimum of 150 mm. Secure the dead end of the rope with a wire rope clip as shown in figure 3;
- before applying the first load always use a hammer to seat the wedge and rope into the socket as deep as possible;
- check the assembly regularly; re-tighten or re-position if necessary;
- never side load a wedge socket as it has not been designed for that purpose;
- load may slip if the connection is not properly installed;
- the efficiency of a wire rope - wedge socket connection is 80% of the minimum breaking load of the wire, but is limited to the minimum breaking load of the socket;
- only use the original wedge supplied by the manufacturer of the socket and be sure it is suitable for the diameter of the rope used;
- never use a wedge from any other supplier than the original socket supplier as the dimensions will not match.

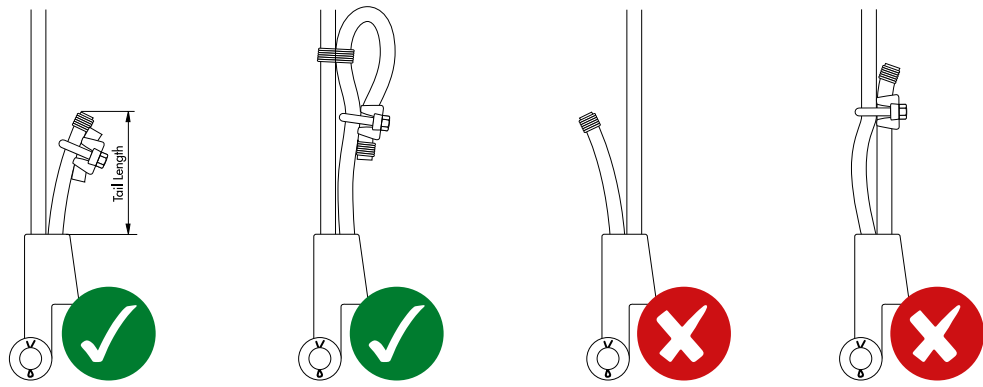

Figure 3

3) Open Long wedge sockets

Verify whether the wedge, socket and wire rope clip match to the wire rope size. In case of the long wedge sockets (G-6419 and G-6429) the correct wire rope size shall be verified using the "GO" and "NO GO" hole (see Figure 4);

- The wire rope MUST pass through the "GO" hole in the wedge;
- The wire rope shall NOT pass through the "NO-GO" hole in the wedge.

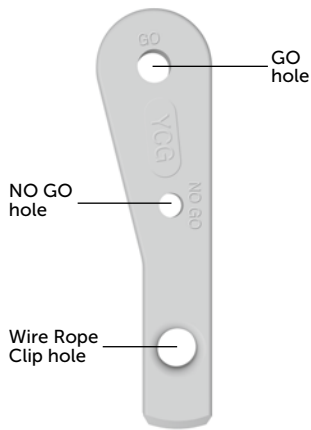

Figure 4

In case of the long wedge sockets (G-6419 and G-6429) mount the corresponding Wire Rope Clip (G-6240) on the dead end section, providing a grip for the tail of the wire rope (see Figure 5 below). The tail length of the wire rope has to be at least 6 times the wire rope diameter with a minimum of 150 mm.

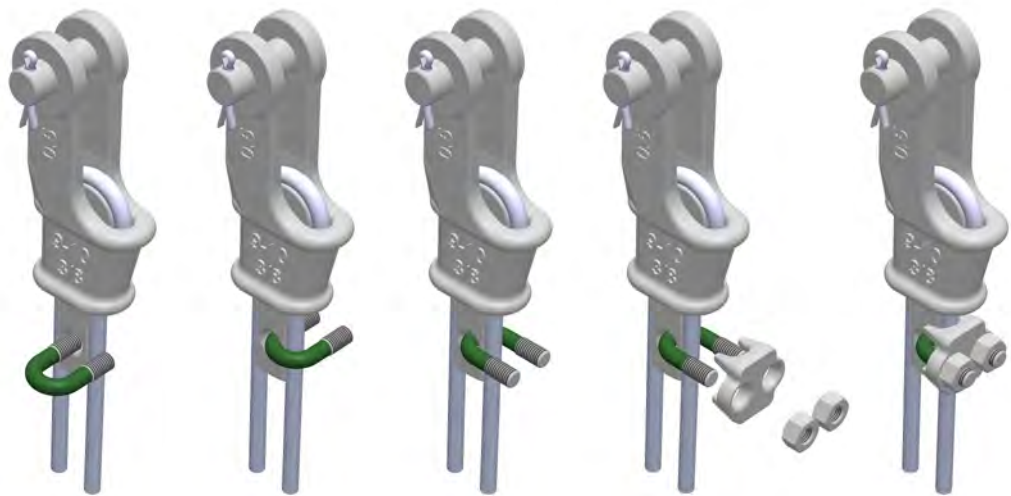

Figure 5

#### 4) Swage sockets

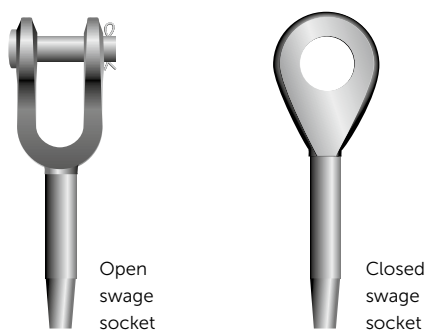

Figure 6

Swage Sockets are recommended for use on 6 x 19 or 6 x 37 IPS or XIP (EIP), XXIP (EEIP), RRL, FC, or IWRC wire ropes. They are also approved for use on galvanized bridge rope. Before using swage socket assemblies, it is recommended that the termination be proof loaded to prove the adequacy of the assembly. Always swage under supervision of a specialist from a certified sling shop.

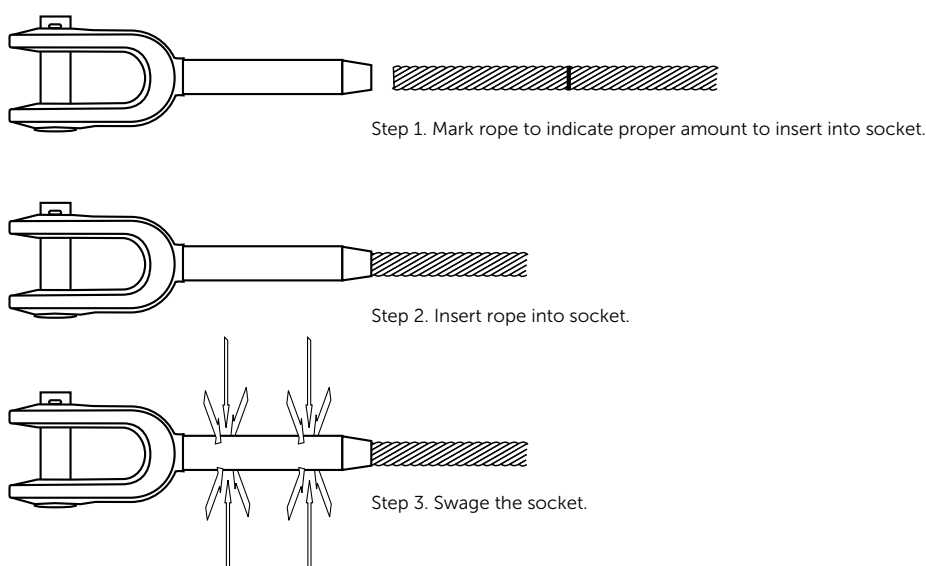

Figure 7

#### INFO

For more instructions on swaging we refer to the swaging instruction (PI-03-14 in the FAQ section) on our website.

Sockets must be regularly inspected in accordance with the safety standards given in the country of use. This is required because the products in use may be affected by wear, misuse, overloading etc. which may lead to deformation and alteration of the material structure. Inspection should take place at least every six months (follow the local rules in the country of use) and more frequently when the sockets are used in severe operating conditions.



G-6411

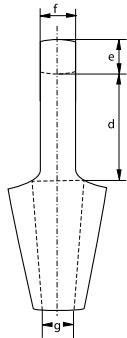
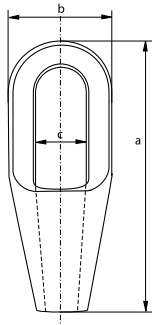

## Green Pin® Closed Spelter Socket

- **Material:** high tensile steel, quenched and tempered
- **Finish:** hot dipped galvanized
- **Temperature Range:** -20 °C up to +200 °C
- **Certification:** 2.1 2.2 3.1 CE IIA
- **Article code:** scan QR code to see article codes

Scan for additional product details



number	minimum breaking load	diameter wire rope	length	width	width inside bow	length inside bow	thickness bow	thickness bow	opening	weight each
	t	mm	a mm	b mm	c mm	d mm	e mm	f mm	g mm	kg
296	8	6 - 7	101	37	22	40	11	13	9	0.27
297	12	8 - 10	119	43	25	48	14	17.5	12	0.43
298	20	11 - 13	140	52	30	58	18	23.5	15	0.76
299	25	14 - 16	162	68	37	66	21	26	17.5	1.52
200	45	18 - 19	194	76	42	78	27	32	21.5	2.31
201	70	20 - 22	224	92	47	90	33	38	24	4.31
204	85	23 - 26	253	104	57	103	36	44	28	6.03
207	105	27 - 30	282	114	63	116	39	51	32	7.99
212	136	31 - 36	312	127	70	130	43	57	38	10.9
215	150	37 - 39	358	136	79	155	51	63	41	13.8
217	170	40 - 42	390	146	83	171	54	70	44	17.4
219	225	43 - 48	443	171	93	198	55	76	51	26.9
222	280	49 - 54	502	193	100	224	62	82	57	38.8
224	360	55 - 60	548	216	112	247	73	92	63	54.7
226	425	61 - 68	597	241	140	270	79	102	73	70.8
227	460	69 - 75	644	273	159	286	79	124	79	102
228	560	76 - 80	686	292	171	298	83	133	86	123
229	625	81 - 86	743	311	184	311	102	146	92	152
230	720	87 - 93	788	330	197	330	102	159	99	178
231	875	94 - 102	845	362	216	356	108	178	108	233
233	1200	108 - 115	1000	405	235	425	125	190	125	329
240	1300	120 - 130	1150	450	260	525	125	200	143	453

CAD

### Socket Lock Socketing Resin



It is advised to use the Socket Lock Socketing Resin in combination with the Green Pin® Spelter Sockets. Go to [www.greenpin.com/socketlock](http://www.greenpin.com/socketlock) for more information about the Socket Lock Socketing Resin. To offer a complete assortment, Green Pin®'s parent company, Royal Van Beest, is the official distributor of Socket Lock Socketing Resin. Green Pin® can supply the Socket Lock resin kit sizes 250, 500, 1000 and 2000 cc from stock.



# Green Pin® Open Spelter Socket CP

## Open spelter socket with cotter pin

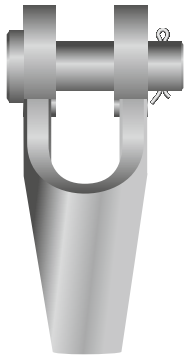

G-6412

- **Material:** high tensile steel, quenched and tempered
- **Finish:** hot dipped galvanized
- **Temperature Range:** -20 °C up to +200 °C
- **Certification:** 2.1 2.2 3.1 CE IIA
- **Article code:** scan QR code to see article codes

number	minimum breaking load	diameter wire rope	length	width	width inside	diameter pin	length inside	opening	weight pin	weight each
	t	mm	a mm	b mm	c mm	d mm	e mm	f mm	kg	kg
196	8	6 - 7	109	51	19	16	33	9	0.9	0.47
197	12	8 - 10	124	62	21	21	34	12	0.17	0.71
198	20	11 - 13	143	66	26	25	37	15	0.26	1.04
199	25	14 - 16	172	82	33	30	49	18	0.47	1.83
100	45	18 - 19	205	95	38	35	58	21	0.74	3.09
104	60	20 - 22	235	110	44	41	68	24	1.19	4.68
108	85	23 - 26	275	130	51	51	75	28	2.15	8.35
111	105	27 - 30	306	144	57	57	85	32	2.95	11.4
115	136	31 - 36	338	155	63	64	95	38	4.02	15.5
118	150	37 - 39	394	178	76	70	127	41	5.54	23.2
120	170	40 - 42	418	187	76	76	127	44	6.89	27.4
125	225	43 - 48	468	213	89	89	133	51	10.6	42.4
128	280	49 - 54	552	240	101	95	180	57	13.7	63.9
130	360	55 - 60	598	270	113	108	196	63	19.9	91.1
132	425	61 - 68	654	303	127	121	212	73	28.1	127
135	460	69 - 75	696	349	133	127	215	79	35.6	164
138	560	76 - 80	737	371	146	133	219	86	41.5	199
140	625	81 - 86	788	391	159	140	228	92	48.5	235
142	720	87 - 93	852	411	171	152	242	99	59.8	294
144	875	94 - 102	914	447	191	178	254	108	89	393
146	1200	108 - 115	1160	489	206	193	368	125	114	642

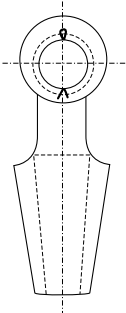
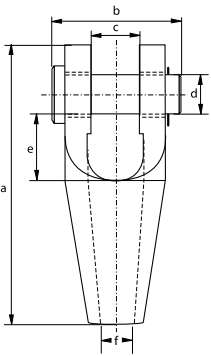

CAD

## Socket Lock Socketing Resin



It is advised to use the Socket Lock Socketing Resin in combination with the Green Pin® Spelter Sockets. Go to [www.greenpin.com/socketlock](http://www.greenpin.com/socketlock) for more information about the Socket Lock Socketing Resin. To offer a complete assortment, Green Pin®'s parent company, Royal Van Beest, is the official distributor of Socket Lock Socketing Resin. Green Pin® can supply the Socket Lock resin kit sizes 250, 500, 1000 and 2000 cc from stock.



## Green Pin® Open Spelter Socket BN

### Open spelter socket with safety bolt

Scan for additional product details

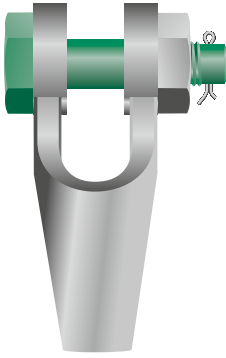

G-6422

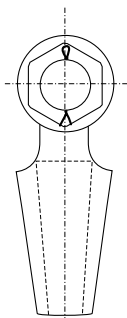
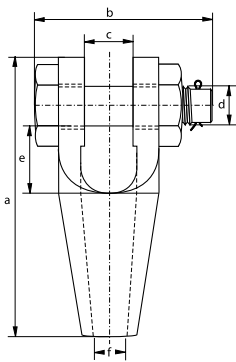

- **Material:** high tensile steel, quenched and tempered
- **Finish:** hot dipped galvanized
- **Temperature Range:** -20 °C up to +200 °C
- **Certification:** 2.1 2.2 3.1 CE IIA
- **Article code:** scan QR code to see article codes

number	minimum breaking load	diameter wire rope	length	width	width inside	diameter pin	length inside	opening	weight pin	weight each
	t	mm	a mm	b mm	c mm	d mm	e mm	f mm	kg	kg
196	8	6 - 7	109	69	19	16	33	9	0.15	0.53
197	12	8 - 10	124	83	21	20	35	12	0.32	0.86
198	20	11 - 13	143	101	26	25	37	15	0.61	1.40
199	25	14 - 16	172	124	33	30	49	18	1.08	2.43
100	45	18 - 19	205	138	38	35	58	21	1.59	3.93
104	60	20 - 22	235	148	44	41	68	24	2.3	5.74
108	85	23 - 26	275	176	51	50	76	28	4.06	10.3
111	105	27 - 30	306	193	57	57	85	32	5.51	14.0
115	136	31 - 36	338	210	63	63	95	38	7.44	18.9
118	150	37 - 39	394	230	76	70	127	41	9.40	27.1
120	170	40 - 42	418	244	76	77	126	44	12.1	32.7

CAD

## Socket Lock Socketing Resin



It is advised to use the Socket Lock Socketing Resin in combination with the Green Pin® Spelter Sockets. Go to [www.greenpin.com/socketlock](http://www.greenpin.com/socketlock) for more information about the Socket Lock Socketing Resin. To offer a complete assortment, Green Pin®'s parent company, Royal Van Beest, is the official distributor of Socket Lock Socketing Resin. Green Pin® can supply the Socket Lock resin kit sizes 250, 500, 1000 and 2000 cc from stock.



# Green Pin® Open Wedge Socket CP

## Open wedge socket with cotter pin

Scan for additional product details



G-6413

- **Material:** high tensile steel, quenched and tempered
- **Standard:** generally to EN 13411-6
- **Finish:** hot dipped galvanized
- **Temperature Range:** -20 °C up to +200 °C
- **Certification:** 2.1 2.2 3.1 CE IIA
- **Article code:** scan QR code to see article codes

number	minimum breaking load	diameter wire rope	length	length to center pin	width	width inside	diameter pin	thickness side plates	diameter eye	weight pin	weight each
	t	mm	a mm	b mm	c mm	d mm	e mm	f mm	g mm	kg	kg
0.25	8	7 - 8	128	110	51	18	16	9	36	0.09	0.83
0.5	12	9 - 10	165	142	62	20.5	21	11	46	0.17	1.58
1	20	11 - 13	175	146	66	25	25	12	57	0.26	2.50
2	25	14 - 16	211	176	82	31	30	15	70	0.47	4.42
3	40	18 - 19	252	212	95	38	35	16	80	0.74	7.76
4	55	20 - 22	288	240	110	44	41	19	95	1.19	11.3
5	75	24 - 26	329	274	130	51	51	22	110	2.16	16.5
6	90	27 - 29	375	310	144	57	57	25	130	2.95	21.8
7	110	30 - 32	423	350	155	63	64	28	146	4.02	31
8	125	34 - 36	474	400	163	69	64	28	148	4.22	39.6
9	150	37 - 39	527	450	178	76	70	30	153	5.54	49.4
10	170	40 - 42	580	500	187	76	76	33	160	6.88	68.1
11	225	43 - 48	650	550	213	89	89	39	186	10.6	94.1

CAD

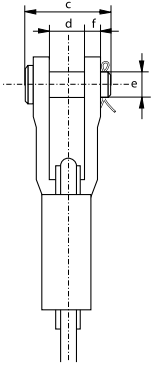
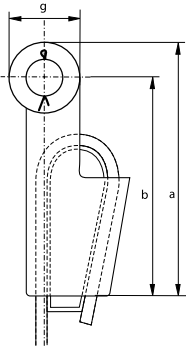



# Green Pin® Open Wedge Socket BN

## Open wedge socket with safety bolt



G-6423

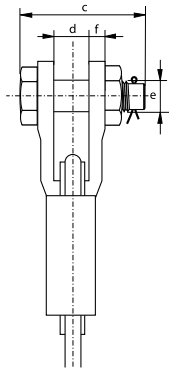
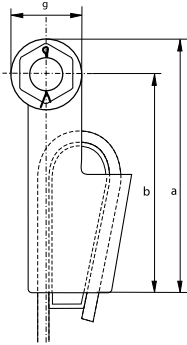

- **Material:** high tensile steel, quenched and tempered
- **Standard:** generally to EN 13411-6
- **Finish:** hot dipped galvanized
- **Temperature Range:** -20 °C up to +200 °C
- **Certification:** 2.1 2.2 3.1 CE IIA
- **Article code:** scan QR code to see article codes

number	minimum breaking load	diameter wire rope	length	length to center pin	width	width inside	diameter pin	thickness side plates	diameter eye	weight pin	weight each
	t	mm	a mm	b mm	c mm	d mm	e mm	f mm	g mm	kg	kg
0.25	8	7 - 8	128	110	69	18	16	9	36	0.15	0.90
0.5	12	9 - 10	165	142	83	20.5	20	11	46	0.32	1.72
1	20	11 - 13	175	146	101	25	25	12	57	0.61	2.86
2	25	14 - 16	211	176	124	31	30	15	70	1.08	5.03
3	40	18 - 19	252	212	138	38	35	16	80	1.59	8.61
4	55	20 - 22	288	240	148	44	41	19	95	2.25	12.4
5	75	24 - 26	329	274	176	51	50	22	110	4.06	18.4
6	90	27 - 29	375	310	193	57	57	25	130	5.51	24.3
7	110	30 - 32	423	350	210	63	63	28	146	7.44	34.4
8	125	34 - 36	474	400	216	69	65	28	148	7.79	43.2
9	150	37 - 39	527	450	230	76	70	30	153	9.4	53.2
10	170	40 - 42	580	500	244	76	77	33	160	12.1	73.3

CAD



## Green Pin® Open Long Wedge Socket CP

Open wedge socket with longer wedge, wire rope clip and cotter pin

Scan for additional product details

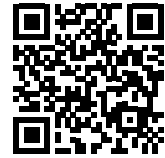

G-6419

- **Material:** high tensile steel
- **Standard:** generally to EN 13411-6
- **Finish:** hot dipped galvanized
- **Temperature Range:** -20 °C up to +200 °C
- **Certification:** 2.1 2.2 3.1 CE IIA
- **Article code:** scan QR code to see article codes

number	minimum breaking load	diameter wire rope	length	length to center pin	width	width inside	diameter pin	thickness side plates	diameter eye	weight pin	weight each
	t	mm	a mm	b mm	c mm	d mm	e mm	f mm	g mm	kg	kg
0.5	12	9 - 10	165	142	62	20.5	21	11	46	0.17	1.88
1	20	11 - 13	175	146	66	25	25	12	57	0.26	3.02
2	25	14 - 16	211	176	82	31	30	15	70	0.47	5.16
3	40	18 - 19	252	212	95	38	35	16	80	0.74	8.80
4	55	20 - 22	288	240	110	44	41	19	95	1.19	12.8
5	75	24 - 26	329	274	130	51	51	22	110	2.16	18.30
6	90	27 - 29	375	310	144	57	57	25	130	2.95	23.7
7	110	30 - 32	423	350	155	63	64	28	146	4.02	33.9

CAD

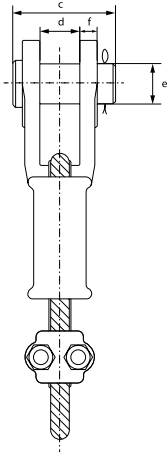
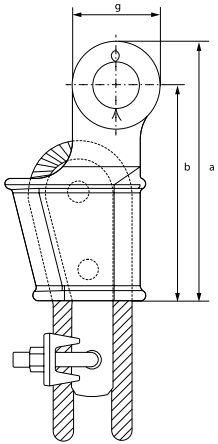



## Green Pin® Open Long Wedge Socket BN

Open wedge socket with longer wedge, wire rope clip and safety bolt



G-6429

- **Material:** high tensile steel
- **Standard:** generally to EN 13411-6
- **Finish:** hot dipped galvanized
- **Temperature Range:** -20 °C up to +200 °C
- **Certification:** 2.1 2.2 3.1 CE IIA
- **Article code:** scan QR code to see article codes

number	minimum breaking load	diameter wire rope	length	length to center pin	width	width inside	diameter pin	thickness side plates	diameter eye	weight pin	weight each
	t	mm	a mm	b mm	c mm	d mm	e mm	f mm	g mm	kg	kg
0.5	12	9 - 10	165	142	83	20.5	20	11	46	0.32	2.02
1	20	11 - 13	175	146	101	25	25	12	57	0.61	3.88
2	25	14 - 16	211	176	124	31	30	15	70	1.08	5.77
3	40	18 - 19	252	212	138	38	35	16	80	1.59	9.65
4	55	20 - 22	288	240	148	44	41	19	95	2.25	13.8
5	75	24 - 26	329	274	176	51	50	22	110	4.06	20.2
6	90	27 - 29	375	310	193	57	57	25	130	5.51	26.3
7	110	30 - 32	423	350	210	63	63	28	146	7.44	37.4

CAD

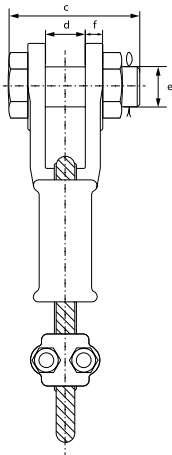
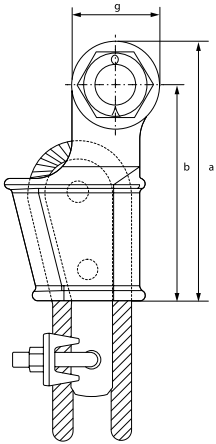



# Green Pin® Short Bow Socket

## Closed spelter socket

- **Material:** cast alloy steel
- **Finish:** hot dipped galvanized
- **Certification:** 2.1 2.2 3.1 CE IIA
- **Article code:** scan QR code to see article codes

Scan for additional product details

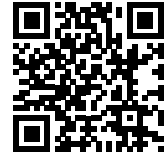

G-6416

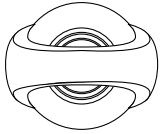
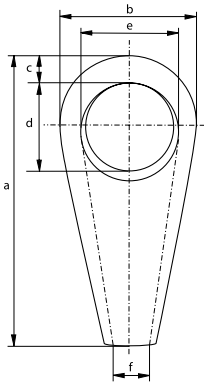

minimum breaking load	rope size	length	width	thicknes bow	length eye	width eye	opening	weight each
t	mm	a mm	b mm	c mm	d mm	e mm	f mm	kg
140	31-36	262	132	38	83	75	39	7
160	37-42	305	152	40	103	92	44	10
200	43-48	356	178	48	120	112	51	16
250	49-54	390	200	54	132	120	57	21
320	55-60	440	220	62	148	135	64	28
400	61-68	498	250	68	165	150	73	44
500	69-75	540	274	75	178	164	79	68
600	76-80	585	295	76	195	175	89	70
700	81-86	625	320	82	216	194	92	81
800	87-93	670	350	92	220	202	99	112
900	94-102	700	375	100	235	215	108	112
1000	108-115	800	420	110	270	240	120	182



## Green Pin® Open Swage Socket CP

Open type swage socket with cotter pin

Scan for additional product details



S-6414

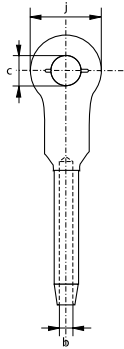
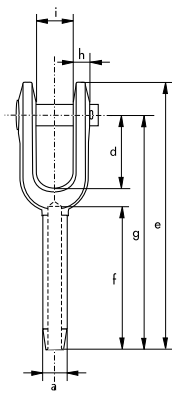

- **Material:** drop forged steel C-1035
- **Finish:** self-coloured
- **Certification:** 2.1
- **Article code:** scan QR code to see article codes

diameter rope	diameter before swage	diameter after swage		diameter inside	diameter pin	length	length	length	length	thickness	width inside	width eye	weight each
		min	max										
mm	a	a	a	b	c	d	e	f	g	h	i	j	kg
6	13	10.9	11.7	7	17	38	121	54	102	8	17	35	0.25
8	20	17.2	18	9	21	44	159	81	135	10	21	41	0.57
10	20	17.2	18	10	21	44	159	81	135	10	21	41	0.56
11	25	22	23.1	12	25	51	198	108	169	13	25	51	1.11
13	25	22	23.1	14	25	51	198	108	169	13	25	51	1.10
14	32	28.3	29.5	15	30	57	243	135	206	16	32	63	2.11
16	32	28.3	29.5	17	30	57	243	135	206	16	32	63	2.06
19	39	34.7	36.1	20	35	70	297	162	254	19	38	76	3.68
22	43	37.8	39.4	24	41	83	346	189	295	23	44	86	5.38
25	50	44.2	45.7	27	51	95	397	216	340	26	51	102	5.45
28	57	50.5	52.1	30	57	108	444	243	381	30	57	114	12
32	64	56.9	58.4	34	64	121	494	270	419	30	63	127	16.3
35	71	63.2	65	37	64	133	540	297	460	33	63	133	20.5
38	78	69.6	71.4	40	70	146	591	324	502	37	76	146	29.5
44	86	75.9	77.7	47	89	171	689	378	584	43	89	178	42.2
51	100	88.6	90.4	54	95	203	798	432	679	46	102	203	65.8
57	113	100.3	102.1	60	108	171	835	486	705	65	114	222	93.4
63	125	110.5	112.3	67	108	171	879	498	749	65	114	222	103
76	151	133.1	134.9	80	133	219	1045	603	905	76	146	241	181

INFO



# Green Pin® Closed Swage Socket

## Closed type

- **Material:** drop forged steel C-1035
- **Finish:** self-coloured
- **Certification:** 2.1
- **Article code:** scan QR code to see article codes

Scan for additional product details



S-6415

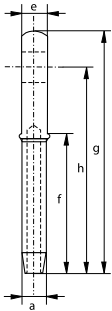
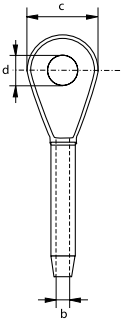

diameter rope mm	diameter before swage a mm	diameter after swage		diameter inside b mm	diameter c mm	diameter eye d mm	thickness e mm	length f mm	length g mm	length h mm	weight each kg
		min a mm	max a mm								
6	13	10.9	11.7	7	37	19	13	54	111	89	0.15
8	20	17.2	18	9	43	22	17	81	140	114	0.35
10	20	17.2	18	10	43	22	17	81	140	114	0.33
11	25	22	23.1	12	51	27	22	108	176	146	0.66
13	25	22	23.1	14	51	27	22	108	176	146	0.62
14	32	28.3	29.5	15	63	32	29	135	222	184	1.35
16	32	28.3	29.5	17	63	32	29	135	222	184	1.31
19	39	34.7	36.1	20	76	37	33	162	264	219	2.30
22	43	37.8	39.4	24	89	43	38	189	308	257	3.40
25	50	44.2	45.7	27	102	52	44	216	349	292	4.97
28	57	50.5	52.1	30	114	59	51	243	387	324	7.20
32	64	56.9	58.4	34	127	65	57	270	438	365	10.5
35	71	63.2	65	37	133	65	57	297	479	400	13.3
38	78	69.6	71.4	40	140	71	63	324	518	432	17.7
44	86	75.9	77.7	47	171	91	76	378	610	508	25.3
51	100	88.6	90.4	54	197	97	83	432	698	584	41
57	113	100.3	102.1	60	219	110	102	486	756	632	55.3
63	125	110.5	112.3	67	219	110	102	498	791	667	64.4
76	151	133.1	134.9	80	235	135	137	603	959	816	114

INFO

## LIFTING SLING FITTINGS FOR WIRE ROPE

# SWIVELS



### Applications

Thrust bearing swivels are used to prevent wire rope or chain from transferring their normal twisting motion to the item being lifted. Green Pin® swivels without bearings are not designed to rotate under load, but are intended as positioning devices only. For rotation under load, thrust bearing swivels should be used. Our swivels can be supplied with two types of end fittings.

### Design

Green Pin® swivels (eye-eye/ jaw-eye) are drop forged. Green Pin® thrust bearing swivels are machined from carbon steel. The range of thrust bearing swivels we supply are fitted with grease nipples to ensure long life and smooth operation. The greasing schedule must be adjusted to the frequency and intensity of use.

Each swivel is generally marked with:

- |  |              |
|--|--------------|
| • Working Load Limit                         | - e.g. 2.4 t |
| • manufacturer's symbol                      | - e.g. GP    |
| • traceability code                          | - e.g. A1    |
| • CE conformity code (conformité Européenne) | - CE         |

### Instructions for use

Swivels should be inspected before use to ensure that:

- all markings are legible;
- a swivel with the correct WLL has been selected;
- the bolt, nut or any other locking system cannot vibrate out of position;
- swivels are free from nicks, gouges and cracks;
- swivels are not distorted or unduly worn.

Also:

- swivels must be used for in-line lifting only;
- swivels may not be heat treated as this may affect their WLL;
- never modify, repair or reshape a swivel by machining, welding, heating or bending as this may affect the WLL.

The WLL should be applied in-line. Avoid overloads. Side loading is not allowed since the swivels are not designed for this purpose. Never replace a swivel pin or nut with a pin other than the one designed for the purpose, as otherwise the swivel may not be suitable for the load imposed. Swivels must be regularly inspected in accordance with the safety standards given in the country of use. This is required because the products in use may be affected by issues such as wear, misuse and overloading, which may lead to deformation and alteration of the material structure. Inspection should take place at least every six months and more frequently when the swivels are used in severe operating conditions.



## Green Pin® EE Swivel

### Swivel with eye-eye end-fitting

- **Material:** high tensile steel, quenched and tempered
- **Safety factor:** MBL equals 5 x WLL
- **Standard:** US Federal Spec. RR-C-271, Type VII, Class 2
- **Finish:** hot dipped galvanized
- **Certification:** 2.1 2.2 CE IIA
- **Article code:** scan QR code to see article codes
- **Note:** for WLL 8.2 t and 20.5 t swivels both eye parts are equipped with a nut



G-7713

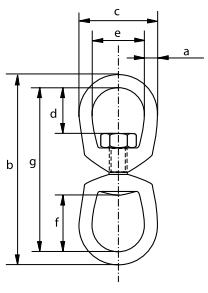

working load limit	diameter	length outside	width outside	length inside	width inside	length inside	length	weight each
t	a mm	b mm	c mm	d mm	e mm	f mm	g mm	kg
0.4	6	87	32	18	19	27	75	0.10
0.6	8	107	41	21	25	32	91	0.18
1.12	10	131	51	24	32	38	111	0.30
1.63	13	164	64	33	38	51	138	0.60
2.4	16	198	76	40	45	61	166	1
3.3	19	221	89	45	51	67	183	1.79
4.54	22	257	102	53	57	78	213	2.55
5.7	25	298	114	59	64	86	248	4.06
8.2	32	357	143	68	80	68	293	8.48
20.5	38	541	198	110	122	110	465	25.7

CAD



## Green Pin® JE Swivel CP

### Swivel with jaw-eye end-fitting and cotter pin

- **Material:** high tensile steel, quenched and tempered
- **Safety factor:** MBL equals 5 x WLL
- **Standard:** US Federal Spec. RR-C-271, Type VII, Class 3
- **Finish:** hot dipped galvanized
- **Certification:** 2.1 2.2 CE IIA
- **Article code:** scan QR code to see article codes



G-7723

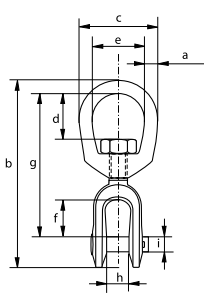

working load limit	diameter	length	width outside	length inside	width inside	length inside	length	width inside	diameter pin	weight each
t	a mm	b mm	c mm	d mm	e mm	f mm	g mm	h mm	i mm	kg
0.4	6	88	32	18	19	22	67	12	6	0.09
0.6	8	99	41	21	25	23	75	13	8	0.16
1.12	10	122	51	24	32	27	92	16	10	0.32
1.63	13	154	64	33	38	33	115	21	13	0.57
2.4	16	184	76	40	45	38	135	26	16	0.98
3.3	19	211	89	45	51	45	154	31	19	1.88
4.54	22	244	102	53	57	52	178	31	23	2.43
5.7	25	297	114	59	64	72	218	47	29	4.02
8.2	32	335	143	68	80	72	240	57	35	7.43
20.5	38	534	198	110	122	116	381	78	51	22.1

CAD



## Green Pin® JE Swivel BN

Swivel with jaw-eye end-fitting and safety bolt



G-7733

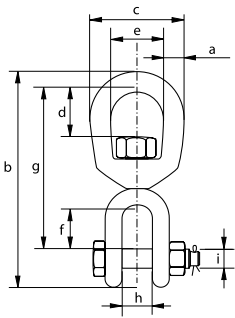

- **Material:** high tensile steel, quenched and tempered
- **Safety factor:** MBL equals 5 x WLL
- **Standard:** US Federal Spec. RR-C-271, Type VII, Class 3
- **Finish:** hot dipped galvanized
- **Certification:** 2.1 2.2 CE IIA
- **Article code:** scan QR code to see article codes

working load limit	diameter	length outside	width outside	length inside	width inside	length inside	length	width inside	diameter pin	weight each
t	a mm	b mm	c mm	d mm	e mm	f mm	g mm	h mm	i mm	kg
0.6	8	99	41	21	25	23	75	13	8	0.16
1.12	10	122	51	24	32	27	92	16	10	0.32
1.63	13	154	64	33	38	33	115	21	13	0.57
2.4	16	184	76	40	45	38	135	26	16	0.98
3.3	19	211	89	45	51	45	154	31	19	1.88
4.54	22	244	102	52	57	53	178	31	22	2.43
5.7	25	297	114	59	64	72	218	47	28	4.02



## Green Pin® Thrust Bearing EE Swivel

Swivel with eye-eye end-fitting and thrust bearings



P-7740

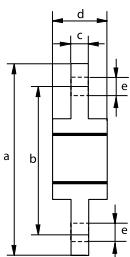

- **Material:** carbon steel
- **Safety factor:** MBL equals 5 x WLL
- **Finish:** painted black
- **Certification:** 2.1 2.2 MTC<sup>2</sup> CE IIA
- **Article code:** scan QR code to see article codes
- **Note:** equipped with two thrust ball bearings to enable rotation under load

working load limit	length	length	thickness	diameter	diameter hole	weight each
t	a mm	b mm	c mm	d mm	e mm	kg
1	174	128	12.5	49	21	1.40
2	223	173	19	68	22	3.50
3	278	210	26	79	29	6.40
5	290	222	26	89	31	7.90
8	366	276	40	106	43	15.2
10	390	300	40	118	49	19.1
15	457	355	40	128	49	26.6
20	474	372	40	118	51	25
30	612	472	64	138	59	50
40	760	600	68	168	65	92

## LIFTING SLING FITTINGS FOR WIRE ROPE

# HOOKS



## Applications

Hooks are used in lifting systems as a connection between the load to be lifted and the wire rope slings.

## Design

There are different types of hooks with specific designs to suit various purposes.

Hooks attachment options to sling:

- Hook with an eye at the top
- Hook with a swivel eye at the top

Hook designs:

- Self-locking hook
- Sling hook
- Sliding Choker Hook

Hooks are generally marked with:

- Working Load Limit (specific products) - e.g. 5.4 t
- manufacturer's symbol - e.g. GP
- traceability code - e.g. H-AB or HA
- steel grade - e.g. 4 or 8
- size in mm and/or inch (specific products) - e.g. 13 and/or 1/2"
- item code (specific products) - e.g. CSO
- origin (specific products) - e.g. France

## Examples of do's and don'ts



A hook cannot be used as a clamp.



Don't use hooks without latch, as an exception is the foundry hook.



Hook body and latch may not be bent. This is a sign the hook is overloaded.

## Instructions for use

Wire rope hooks, should be inspected before use to ensure that:

- all markings are legible.
- a hook with the correct WLL has been selected with respect to the sling design.
- hooks are free from nicks, gouges, and cracks.
- hooks are not heat treated, modified, repaired, or reshaped by machining or bended. (This may affect their Working Load Limit).
- hooks are not distorted or unduly worn. (Maximum allowable wear is 10 % of the original diameter)
- the latch of the hook(s) is present and functional.
- the hook is never side-, tip- or back- loaded.
- the hook is supporting the load correctly.
- the latch should not be supporting any load.
- only use the hook for in-line lifting.

Hooks must be regularly inspected in accordance with the safety standards given in the country of use. This is required because the products in use may be affected by issues such as wear, misuse and overloading, which may lead to deformation and alteration of the material structure. Inspection should take place at least every six months (follow the local rules in the country of use), and more frequently when the links are used in severe operating conditions.

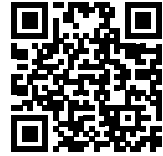

## Green Pin® Sling Hook E EN 1677-2 GR8

### Grade 8 eye sling hook EN 1677-2



- **Material:** alloy steel, grade 8, quenched and tempered
- **Safety factor:** MBL equals 4 x WLL
- **Standard:** EN1677-2 and ASTM A952/A952M
- **Finish:** painted yellow (J), red (R) or white
- **Temperature range:** -40 °C up to +200 °C
- **Certification:** 2.1 2.2 3.1 \* MTC<sup>a</sup> MPI<sup>b</sup> \* DGUV \* CE IIB
- **Article code:** scan QR code to see article codes
- **Note:** from 8.2 t without flat part. For use of this component in a wire rope sling the safety factor must be 5 : 1, see the table on page 84

CSO

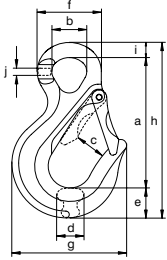

for chain diameter	working load limit	length	diameter inside eye	width opening	thickness	width	diameter eye outside	width outside	length outside	width	thickness	weight each
mm	t	a mm	b mm	c mm	d mm	e mm	f mm	g mm	h mm	i mm	j mm	kg
5/6	1.12	86	23	26	15	19	43	72	114	10	6	0.28
7/8	2	103	26	30	20	24	51	87	139	12	8	0.56
10	3.2	129	36	33	24	28	65	106	171	15	10	1.08
13	5.4	152	41	37	32	39	77	133	209	18	12	1.90
16	8.2	191	52	43	40	43	94	165	255	21	17	3.50
18/20	12.8	237	61	61	49	61	115	208	326	28	21	7.04
22	15.5	280	72	75	54	64	132	242	375	30	23	9.95
26**	21.6	251	48	73	55	86	111	236	363	32	32	14.1
32**	32.8	292	58	87	67	104	139	286	435	39	39	21.7

\* Excluding sizes 26 mm and 32 mm

\*\* Different design

INFO CAD



## Green Pin® Sling Hook SE EN 1677-2 GR8

### Grade 8 swivel sling hook EN 1677-2



- **Material:** alloy steel, grade 8, quenched and tempered
- **Safety factor:** MBL equals 4 x WLL
- **Standard:** EN1677-2 and ASTM A952/A952M
- **Finish:** painted yellow (J), red (R) or white
- **Temperature range:** -40 °C up to +200 °C
- **Certification:** 2.1 2.2 3.1 MTC<sup>a</sup> MPI<sup>b</sup> DGUV CE IIB
- **Article code:** scan QR code to see article codes
- **Note:** equipped with thrust needle roller bearings to enable rotation under load and need to be used with rotating resistant wires. For use of this component in a wire rope sling the safety factor must be 5 : 1, see the table on page 84

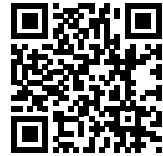

CSE

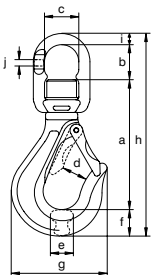

for chain diameter	working load limit	length	length inside	width inside	width opening	thickness	width	width outside	length outside	diameter	thickness	weight each
mm	t	a mm	b mm	c mm	d mm	e mm	f mm	g mm	h mm	i mm	j mm	kg
5/6	1.12	100	33	32	26	15	20	72	164	12	6	0.54
7/8	2	126	40	37	30	20	25	87	204	14	8	1
10	3.2	158	47	48	33	24	29	106	250	16	11	1.90
13	5.4	189	59	58	37	32	39	133	308	21	14	3.40
16	8.2	221	67	73	44	40	44	165	356	25	17	6.35
18/20	12.8	263	87	82	61	49	62	209	437	25	21	10.4

INFO CAD



P-6714A

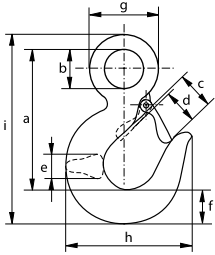

## Green Pin® Hook E GR8

### Grade 8 large eye hook with safety latch

- **Material:** alloy steel, grade 8, quenched and tempered
- **Safety factor:** MBL equals 4 x WLL
- **Standard:** generally to EN 1677-2
- **Finish:** painted red
- **Temperature range:** -20 °C up to +200 °C
- **Certification:** 2.1 2.2 3.1 CE IIA
- **Article code:** scan QR code to see article codes
- **Note:** for use of this component in a wire rope sling the safety factor must be 5 : 1, see the table on page 84

Scan for additional product details



working load limit	length	diameter eye inside	opening hook	opening hook	thickness	width	diameter eye outside	width outside	length outside	weight each
t	a mm	b mm	c mm	d mm	e mm	f mm	g mm	h mm	i mm	kg
1.25	81	19	24	20	16	19	37	70	109	0.30
1.6	91	23	26	22	18	22	46	79	124	0.44
2.5	105	27	32	27	20	27	52	93	145	0.63
3.2	124	32	34	30	24	30	62	109	169	1.08
5.4	147	39	44	37	31	36	74	127	201	1.56
8.2	190	50	55	48	37	48	96	168	261	3.95
12.8	230	64	64	53	48	61	126	198	322	7.75
16	254	71	70	60	58	69	139	223	357	10.8
22	316	89	91	77	63	81	169	283	437	16.9

CAD



## Green Pin® Hook SE GR8

### Grade 8 swivel eye hook with safety latch

Scan for additional product details

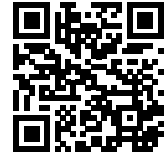

P-6703A

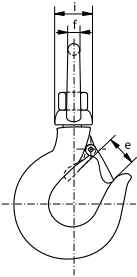
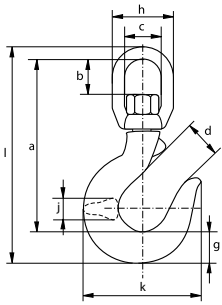

- **Material:** alloy steel, grade 8, quenched and tempered
- **Safety factor:** MBL equals 4 x WLL
- **Finish:** painted red
- **Temperature range:** -20 °C up to +200 °C
- **Certification:** 2.1 2.2 3.1 CE IIA
- **Article code:** scan QR code to see article codes
- **Note:** for use of this component in a wire rope sling the safety factor must be 5 : 1, see the table on page 84

working load limit	length	length inside	width inside	opening hook	opening hook	diameter	width	width	width	thickness	width outside	length outside	weight each
t	a	b	c	d	e	f	g	h	i	j	k	l	kg
1.25	118	28	31	24	20	11	19	53	30	16	70	147	0.49
1.6	145	35	40	26	22	14	22	68	37	18	79	181	0.95
2.5	167	43	47	32	27	17	27	81	43	20	93	210	1.48
3.2	180	47	47	34	30	17	31	81	43	24	109	228	1.78
5.4	217	54	64	44	37	21	36	106	64	31	127	275	3.70
8.2	275	69	78	55	45	26	48	130	77	37	168	349	7.36
11.5	310	68	82	58	53	22	60	150	82	43	198	398	9.69
16	352	84	92	66	58	24	67	154	92	52	222	452	14.9
22	434	107	115	87	78	29	80	191	108	64	283	552	26
31.5	512	117	132	97	87	34	94	222	132	80	339	655	46

CAD



## Green Pin® Self Locking Hook E EN 1677-3 GR8

### Grade 8 eye self locking hook EN 1677-3



XLO

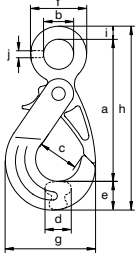

- **Material:** alloy steel, grade 8, quenched and tempered
- **Safety factor:** MBL equals 4 x WLL
- **Standard:** EN1677-3 and ASTM A952/A952M
- **Finish:** painted yellow (J), red (R) or white
- **Temperature range:** -40 °C up to +200 °C
- **Certification:** 2.1 2.2 3.1 MTC<sup>a</sup> MPI<sup>b</sup> DGUV CE IIB
- **Article code:** scan QR code to see article codes
- **Note:** from 12.8 t without flat part  
for use of this component in a wire rope sling the safety factor must be 5 : 1, see the table on page 84



for chain diameter	working load limit	length	diameter inside eye	width opening	thickness	width	width outside	width outside	length	width	thickness	weight each
mm	t	a mm	b mm	c mm	d mm	e mm	f mm	g mm	h mm	i mm	j mm	kg
5/6	1.12	113	24	32	16	24	47	75	148	11	6	0.51
7/8	2	136	30	43	24	28	57	91	178	14	8	0.91
10	3.2	168	36	48	32	34	68	111	218	16	10	1.79
13	5.4	201	47	63	37	43	87	141	264	20	13	3.36
16	8.2	251	60	75	43	56	111	182	332	26	16	7
18/20	12.8	283	70	90	52	62	126	203	373	28	21	9.22

CAD INFO



## Green Pin® Self Locking Hook E GR8

### Grade 8 eye self locking hook



GKO

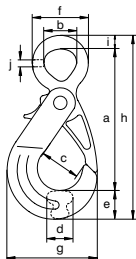

- **Material:** alloy steel, grade 8, quenched and tempered
- **Safety factor:** MBL equals 4 x WLL
- **Finish:** painted yellow (J), red (R) or white
- **Temperature range:** -40 °C up to +200 °C
- **Certification:** 2.1 2.2 MTC<sup>a</sup> MPI<sup>b</sup> CE IIB
- **Article code:** scan QR code to see article codes
- **Note:** GK hooks are more compact than XL hooks  
for use of this component in a wire rope sling the safety factor must be 5 : 1, see the table on page 84

for chain diameter	working load limit	length	diameter inside eye	width opening	thickness	width	width outside	width outside	length	width	thickness	weight each
mm	t	a mm	b mm	c mm	d mm	e mm	f mm	g mm	h mm	i mm	j mm	kg
7/8	2	112	26	32	17	24	48	75	147	11	9	0.53
10	3.2	136	31	44	24	28	60	91	179	15	10	0.96
13	5.4	174	40	48	32	33	76	111	226	18	12	1.86
16	8.2	209	50	63	37	42	93	141	273	22	16	3.49
18/20	12.8	254	61	75	44	55	116	184	337	28	20	7.33
22	15.5	288	72	90	52	61	132	205	379	30	21	9.91

CAD INFO



## Green Pin® Self Locking Hook SE EN 1677-3 GR8

### Grade 8 swivel self locking hook EN 1677-3



XLE

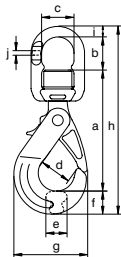

- **Material:** alloy steel, grade 8, quenched and tempered
- **Safety factor:** MBL equals 4 x WLL
- **Standard:** EN1677-3 and ASTM A952/A952M
- **Finish:** painted yellow (J), red (R) or white
- **Temperature range:** -40 °C up to +200 °C
- **Certification:** 2.1 2.2 3.1 MTC<sup>a</sup> MPI<sup>b</sup> DGVV CE IIB
- **Article code:** scan QR code to see article codes
- **Note:** equipped with thrust needle roller bearings to enable rotation under load and need to be used with rotating resistant wires for use of this component in a wire rope sling the safety factor must be 5 : 1, see the table on page 84



for chain diameter	working load limit	length	length inside	width inside	width opening	thickness	width	width outside	length	diameter	thickness	weight each
mm	t	a mm	b mm	c mm	d mm	e mm	f mm	g mm	h mm	i mm	j mm	kg
5/6	1.12	123	33	32	32	16	24	75	191	12	6	0.78
7/8	2	149	41	37	43	24	28	91	232	14	8	1.39
10	3.2	186	47	48	48	32	34	112	283	16	11	2.56
13	5.4	214	60	58	63	37	44	141	337	21	14	4.56
16	8.2	273	67	73	75	43	56	182	420	25	17	9.50
18/20	12.8	304	87	82	90	52	62	205	478	25	22	12.7

CAD INFO



## Green Pin® Self Locking Hook SE GR8

### Grade 8 swivel self locking hook



GKE

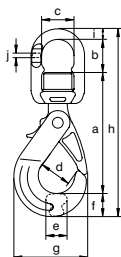

- **Material:** alloy steel, grade 8, quenched and tempered
- **Safety factor:** MBL equals 4 x WLL
- **Finish:** painted yellow (J), red (R) or white
- **Temperature range:** -40 °C up to +200 °C
- **Certification:** 2.1 2.2 MTC<sup>a</sup> MPI<sup>b</sup> CE IIB
- **Article code:** scan QR code to see article codes
- **Note:** equipped with thrust needle roller bearings to enable rotation under load and need to be used with rotating resistant wires GK hooks are more compact than XL hooks for use of this component in a wire rope sling the safety factor must be 5 : 1, see the table on page 84



for chain diameter	working load limit	length	length inside	width inside	width opening	thickness	width	width outside	length	diameter	thickness	weight each
mm	t	a mm	b mm	c mm	d mm	e mm	f mm	g mm	h mm	i mm	j mm	kg
7/8	2	123	33	32	32	17	24	75	191	12	6	0.77
10	3.2	149	41	37	44	24	28	91	231	14	8	1.38
13	5.4	186	47	48	48	32	33	111	282	16	11	2.56
16	8.2	214	60	58	63	37	42	141	336	21	14	4.58
18/20	12.8	272	67	73	75	45	55	184	418	25	17	9.51

CAD INFO



P-6706A

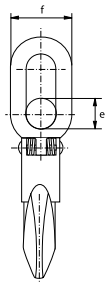
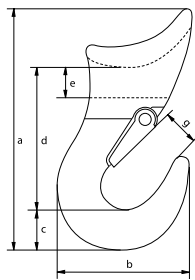

## Green Pin® Alloy Sliding Choker Hook

### Grade 8 sliding choker hook with safety latch

- **Material:** alloy steel, grade 8, quenched and tempered
- **Safety factor:** MBL equals 5 x WLL
- **Finish:** painted red
- **Temperature range:** -20 °C up to +200 °C
- **Certification:** 2.1 2.2 3.1 CE IIA
- **Article code:** scan QR code to see article codes

Scan for additional product details



working load limit	diameter rope	length	width	thickness	length	diameter	thickness	opening hook	weight each
t	mm	a mm	b mm	c mm	d mm	e mm	f mm	g mm	kg
0.8	6 - 11	112	63	19	65	14	30	16	0.40
1.6	10 - 13	143	82	26	83	17	30	18	0.76
2.5	14 - 16	170	98	30	97	19	33	24	1.28
3.2	16 - 20	196	115	36	110	22	40	27	1.91
5.4	22 - 26	260	142	46	145	36	60	35	4.20

CAD

C

## Eye hook

### Grade 4 large eye hook with safety latch

- **Material:** carbon steel, grade 4
- **Safety factor:** MBL equals 5 x WLL
- **Finish:** painted green
- **Certification:** 2.1 2.2 3.1 CE IIA



P-6714C

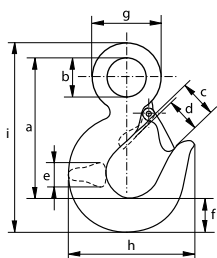

working load limit	length	diameter eye inside	opening hook	opening hook	thickness	width	diameter eye outside	width outside	length outside	weight each
t	a mm	b mm	c mm	d mm	e mm	f mm	g mm	h mm	i mm	kg
0.8	81	19	24	20	16	19	37	70	109	0.29
1	91	23	26	22	18	22	46	79	124	0.44
1.6	105	27	32	27	20	27	52	93	145	0.64
2	124	32	34	30	24	30	62	109	169	1.08
3.2	147	39	44	37	31	36	74	127	201	1.81
5	190	50	55	48	37	48	96	168	261	3.75

CAD



## Green Pin® ID Tag

### Aluminium identification tag

- Material: aluminium
- Finish: see table below
- Certification: 2.1

Scan for additional product details

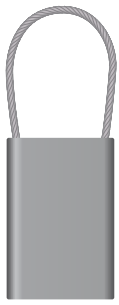

TAG

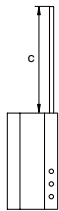
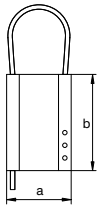

partnumber	finish	width	length	length	weight each
		a mm	b mm	c mm	
TAGVIERGE	self-coloured	51	76	220	0.07
TAGJ	anodized yellow	51	76	220	0.07
TAGGREEN	anodized green	51	76	220	0.07
TAGRED	anodized red	51	76	220	0.07
TAGBLUE	anodized blue	51	76	220	0.07
TAGDEMI	self-coloured	51	38	220	0.04
TAGB without wire rope	self-coloured	51	76		0.06



TAGVIERGE

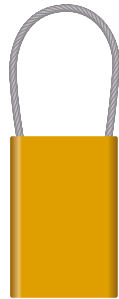

TAGJ



TAGGREEN



TAGRED



TAGBLUE

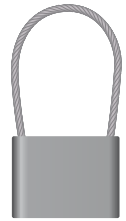

TAGDEMI

Scan for additional product details

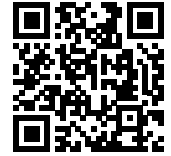

## Green Pin® RFID Tag

### Accessory for radio-frequency identification of slings

- **Material:** stainless steel
- **Standard:** RF Protocol ISO 15693 Operating Frequency HF - 13.56 MHz with individual serial number
- **Finish:** polymer
- **Temperature range:** -40 °C up to +125 °C
- **Certification:** 2.1
- **Note:** IP68; water and ice proof

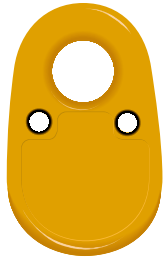

TAGRfid

length	width	diameter	diameter	weight per 100 pcs
a mm	b mm	c mm	d mm	kg
53	33	12	4	1.80

RFID INFO

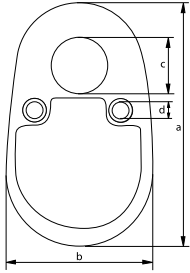

## Green Pin® RFID Chip

### Accessory for radio-frequency identification of slings

- **Material:** polymer
- **Standard:** RF Protocol ISO 15693 Operating Frequency HF - 13.56 MHz with individual serial number
- **Temperature range:** -40 °C up to +125 °C
- **Certification:** 2.1
- **Note:** IP68; water and ice proof



CHIPRFID

diameter	thickness	weight per 100 pcs
a mm	b mm	kg
6	2	0.02

RFID INFO

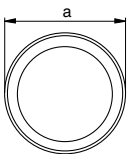

# LIFTING SLING FITTINGS FOR GRADE 8 CHAIN



## Applications

Green Pin® grade 8 lifting sling fittings enable the assembly of a complete sling from the top master link to the hooks.

For specific product information the following product groups can be found on the mentioned page:







Top links					
					
<b>MS</b> page 150	<b>MTS</b> page 151				
Connectors					
					
<b>MP</b> page 152	<b>CO</b> page 152	<b>MJ</b> page 153			
Chain					
					
<b>CHAIN</b> page 153					

Table continues on next page

Shorteners					
					
<b>CRO</b> page 154	<b>CRC</b> page 154	<b>GC</b> page 155	<b>GCV</b> page 155	<b>GDV</b> page 156	
End-fittings					
					
<b>ELR</b> page 156	<b>CSO</b> page 157	<b>CSC</b> page 157	<b>CSE</b> page 158	<b>CSECA</b> page 158	<b>P-6714A</b> page 159
					
<b>P-6703A</b> page 161	<b>P-6731</b> page 161	<b>XLO</b> page 162	<b>GKO</b> page 162	<b>XLC</b> page 163	<b>GKC</b> page 163
					
<b>XLE</b> page 164	<b>GKE</b> page 164	<b>XLBA</b> page 165	<b>GH</b> page 166	<b>CFO</b> page 166	
Accessories					
					
<b>TAG</b> page 167	<b>TAGF</b> page 167	<b>TAGRFID</b> page 168	<b>CHIPRFID</b> page 168	<b>VR</b> page 169	<b>AC</b> page 170
					
<b>RMJ</b> page 171	<b>LF</b> page 172	<b>RCOS</b> page 173			

## Range

Green Pin® supplies a range of grade 8 lifting sling fittings for 5 mm to 32 mm chain diameters.

Below lifting sling fittings can be found:

- Links, e.g. Green Pin® Master Link, Connecting Link
- Chain, e.g. Green Pin® Lifting Chain EN818-2 Grade 8
- Swivel, e.g. Green Pin® Needle Bearing Swivel Eye-Eye
- Hooks, e.g. Green Pin® Sling Hook, Self Locking Hook

## Design

Connecting links and lifting sling fittings with clevis connection are supplied unassembled and ready for immediate use. Assembly is quick and easy.

Master links, eye hooks and eye swivels are generally supplied with a flat part for easy connection to the sling or for easy assembly with the omega link.

There are different types of hooks with specific designs to suit various purposes.

### Hooks attachment options to sling:

- Hook with an eye at the top
- Hook with a swivel eye at the top
- Hook with a clevis at the top
- Hook with a clevis swivel eye at the top

### Hook designs:

- Self-locking hook
- Compact self-locking hook
- Sling hook
- Grab hook
- Foundry hook
- Excavator hook
- Pipe line hook

### Clevis fittings for hoist chains:

- Specific load pins designed for 5, 7 and 9 mm hoist chains available on request.
- Specific load pins can be mounted only on Green Pin chain fittings: CO omega links, MP pear shape links, Green Pin® clevis sling hooks and Green Pin® clevis self locking hooks.
- WLL of the fitting must be decreased according to the hoist chain WLL. Please refer to the WLL indicated by the hoist chain manufacturer. The lowest WLL has to be considered.
- These specific load pins must be exclusively used with a hoist chain.

### Self locking hooks GK vs XL:

- The GK hook is more compact/smaller than the self locking XL hook at the equivalent chain diameter.
- The GK hook is lighter than the XL hook at the equivalent chain diameter.

Chain slings can be shortened by using a grab hook or a shortening clutch.

### Grade 8 lifting sling fittings are generally marked with:

- manufacturer's symbol - e.g. GP
- size in mm and inch - e.g. 13 and 1/2"
- traceability code - e.g. HA
- steel grade - e.g. 8
- item code (specific products) - e.g. MJ
- origin (specific products) - e.g. France
- DGUV certified (specific products) - e.g. H94

As prescribed by the Machinery Directive 2006/42/EC our hooks, master links and connecting links are supplied with a CE Declaration of Incorporation (CE IIB), stating the products are in compliance with the requirements of the machinery directive. These products do not have a CE marking, since CE markings are only to be provided for machines, whereas hooks, master links and connecting links are components of machines, and not machines themselves. Providing components with a CE marking is an incorrect interpretation of the Machinery Directive.

Machinery definition according to Machinery Directive 2006/42/EC – Article 2 – definitions (a) and Machinery Regulation 2023/1230/EU:

"An assembly of linked parts or components, at least one of which moves and which are joined together, intended for lifting loads and whose only power source is directly applied human effort."

"The maximum working load shall be prominently marked on the lifting machinery. The marking shall be legible, indelible and in an un-coded form. Where the maximum working load depends on the configuration of the lifting machinery, each operating position shall be provided with a load plate indicating, preferably in diagrammatic form or by means of tables, the working load permitted for each configuration."

This definition means that a sling is a Machine and that the hooks, master links and connecting links are not considered as a machine themselves, but as components of a machine. The CE and the WLL markings in consequence, are mandatory only on the assembled sling tag as the sling is the machine according to MD 2006/42/EC. This rule is still valid with the new Machine Regulation 2023/1230 which will replace the MD cited previously within early 2027.

## Finish

All grade 8 lifting sling fittings are painted. Grade 8 lifting sling fittings under the Green Pin® brand will be painted white.

Some products are mentioned as painted white\*, but could be for some sizes delivered with a yellow or red finish. The P-6714A, P-6703A and P-6731 hooks are painted red.

## Certification

Specific details of certificate availability can be found on each product page. Please verify your certification requirements with Green Pin® at the time of order.

## Instructions for use

Grade 8 lifting sling fittings, should be inspected before use to ensure that:

- all markings are legible.
- all lifting sling fittings of the complete sling are made of the same steel grade 8.
- a lifting sling fitting with the correct WLL has been selected with respect to the sling design. For further details, refer to the EN 818-4 and ASME B30.9 standard for Chain Slings.
- the pin, bolt, nut, bush or any other locking system cannot move, or vibrate out of position.
- lifting sling fittings are free from nicks, gouges, and cracks.
- lifting sling fittings are not heat treated, modified, repaired or reshaped by machining or bent. (This may affect their Working Load Limit).
- lifting sling fittings items are not distorted or unduly worn. (Maximum allowable wear is 10 % of the original diameter)
- the latch of the hook(s) is present and functional.
- the hook is never side-, tip- or back- loaded.
- the hook is supporting the load correctly.
- the latch should not be supporting any load.
- only use the lifting sling fittings for in-line lifting.

Grade 8 lifting sling fittings must be regularly inspected in accordance with the safety standards given in the country of use. This is required because the products in use may be affected by issues such as wear, misuse and overloading, which may lead to deformation and alteration of the material structure. Inspection should take place at least every six months (follow the local rules in the country of use), and more frequently when the links are used in severe operating conditions.

## Testing

Generally load rated products are proof load and/or MPI tested. For specific information on certificates we refer to the separate paragraph on certification.

Green Pin® grade 8 lifting sling fittings are proof load tested at the following loads:

for chain diameter	Working Load Limit (WLL)	Proofload (PL)
mm	t	t
6	1.12	2.8
7	1.57	3.93
8	2	5
10	3.2	8
13	5.4	13.5
16	8.2	20.5
20	12.8	32
22	15.5	38.75
26	21.6	54
32	32.8	82

### Temperature

If extreme temperature situations occur, the following load reductions must be taken into account:

Temperature °Celsius	Temperature °Fahrenheit	Reduction for elevated temperatures New Working Load Limit
-40 °C up to 200 °C	-40 °F up to 392 °F	100 % of original WLL
200 - 300 °C	392 - 572 °F	90 % of original WLL
300 - 400 °C	572 - 752 °F	75 % of original WLL
> 400 °C	> 752 °F	not allowed

Note: P-6714A, P-6703A and P-6731 temperature range -20 °C up to +200 °C cannot be used above +200 °C.

### Working Load Limit table for Grade 8 Chain Slings to EN 818-4

Chain Ø						
	1 leg sling	2 leg sling		3 or 4 leg sling		Endless Sling
	90°	0° <math>\beta \le 45^\circ</math> Safety factor 1.4	45° <math>\beta \le 60^\circ</math> Safety factor 1.0	0° <math>\beta \le 45^\circ</math> Safety factor 2.1	45° <math>\beta \le 60^\circ</math> Safety factor 1.5	Safety factor 1.6
mm	t	t	t	t	t	t
6	1.12	1.60	1.12	2.36	1.70	1.80
7	1.50	2.12	1.50	3.15	2.24	2.50
8	2.00	2.80	2.00	4.25	3.00	3.15
10	3.15	4.25	3.15	6.70	4.75	5.00
13	5.30	7.50	5.30	11.20	8.00	8.50
16	8.00	11.20	8.00	17.00	11.80	12.50
20	12.50	17.00	12.50	26.50	19.00	20.00
22	15.00	21.20	15.00	31.50	22.40	23.60
26	21.20	30.00	21.20	45.00	31.50	33.50
32	31.50	45.00	31.50	67.00	47.50	50.00

When using multi leg slings make sure that the angles between the lifting points and sling legs are within the range marked on the sling. The angle  $\beta$ , which is the angle between the sling leg and the vertical, should never exceed 60°.

### Symmetry of loading

The WLL values mentioned are based on symmetrical loading of the sling. This means that when the load is lifted, the sling legs are symmetrically distributed in the plane and all legs of the sling have the same angle to the vertical. For more details on chain slings refer to EN 818-6:2000+A1:2008.

The loading can be assumed to be symmetric if all the following conditions are met:

- the load is less than 80% of marked WLL, and
- sling leg angles to the vertical are all more than 15°, and
- sling leg angles to the vertical are all within 15° to each other, and
- in the case of three- and four-leg slings, the plane angles are within 15° of each other.

If one of the above parameters is not met, the loading should be considered to be asymmetric, and the lift should be referred to a competent engineer to establish the safe rating for the sling. Alternatively, in the case of asymmetric loading, the sling should be derated to half the marked WLL. If the load tends to tilt during the lift, it should be lowered, and the attachments changed by repositioning the attachment points or by using compatible shortening devices. The safety factor of 4 on the individual components is designed for safety only. Never exceed the indicated WLL.

Use the below reduction table if a multi leg sling is not used for the purpose for which it has been designed, for example for a lifting operation with fewer legs than the number of legs of the sling:

Types of chain sling	Number of legs used	Factor to apply to marked WLL
Two-leg	1	1/2
Three- and four-leg	2	2/3
Three- and four-leg	1	1/3

Examples of do's and don'ts



A hook cannot be used as a clamp.



Don't use hooks without latch, as an exception is the foundry hook.



Hook body and latch may not be bent. This is a sign the hook is overloaded.



Position the chain properly in the throat.



Do not tip load hooks.



Correct positioned or mounted

Wrong applied

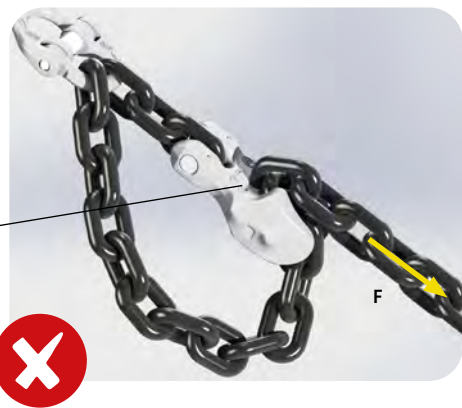

Load (F) bearing chain always needs to be at the bottom of the shortening clutch.



MS

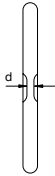
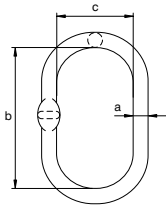

# Green Pin® Master Link EN 1677-4 GR8

## Grade 8 master link EN 1677-4

- **Material:** alloy steel, grade 8, quenched and tempered
- **Safety factor:** MBL equals 4 x WLL
- **Standard:** EN 1677-4, ASTM A952/952M and ASME B30.9
- **Finish:** painted white\*
- **Temperature range:** -40 °C up to +200 °C
- **Certification:** 2.1 2.2 3.1 MTC<sup>®</sup> MPI<sup>®</sup> CE IIB
- **Article code:** scan QR code to see article codes
- **Note:** from 50 t without flat part

Scan for additional product details



diameter	diameter chain 1 leg	diameter chain 2 legs		working load limit	length inside	width inside	thickness	weight each
a mm	mm	$\beta \leq 45^\circ$ mm	$45^\circ < \beta \leq 60^\circ$ mm	t	b mm	c mm	d mm	kg
13	6/7	6	6/7	1.6	115	60	7	0.40
16	8	7/8	8	3.2	120	70	7	0.60
18	10	10	10	4.5	135	75	9	0.84
20	13	-	13	6.2	150	82	11	1.10
22	16	13	16	8.2	170	90	14	1.60
25	18	-	18	10.6	190	103	14	2.30
28	20	16	19	12.8	209	120	17	3.10
30	20/22	18	20/22	15.5	235	125	17	4
36	-	19/20	-	20	270	145	22	6.60
38	26	22	26	25	250	150	22	7.10
45	32	26	32	37	300	200	22	12.1
50	-	32	-	50	380	200	-	18
55	-	-	-	63	360	200	-	21
70	-	-	-	100	500	250	-	44
80	-	-	-	125	503	280	-	60.7

CAD INFO

\* could be delivered with a yellow or red finish



# Green Pin® Master Link Assembly EN 1677-4 GR8

## Grade 8 master link assembly EN 1677-4

Scan for additional product details



MTS

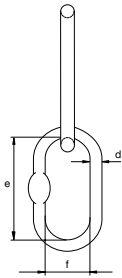
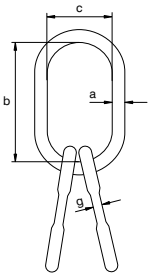

- **Material:** alloy steel, grade 8, quenched and tempered
- **Safety factor:** MBL equals 4 x WLL
- **Standard:** EN 1677-4, ASTM A952/952M and ASME B30.9
- **Finish:** painted white\*
- **Temperature range:** -40 °C up to +200 °C
- **Certification:** 2.1 2.2 3.1 MTC<sup>b</sup> MPI<sup>a</sup> CE IIB
- **Article code:** scan QR code to see article codes
- **Note:** from 60 t without flat part

diameter	diameter chain 3/4 legs		working load limit	length inside	width inside	diameter	length inside	width inside	thickness	weight each
a mm	$\beta \leq 45^\circ$ mm	$45^\circ < \beta \leq 60^\circ$ mm	t	b mm	c mm	d mm	e mm	f mm	g mm	kg
16	6	6/7	2.5	120	70	13	115	60	7	1.20
18	6/7	8	3.5	135	75	16	120	70	7	3.10
22	8	10	6.5	170	90	18	135	75	9	3.30
25	10	13	8.5	190	103	20	150	82	11	4.50
28	-	-	10	209	120	20	150	82	11	5.40
30	13	16	13	235	125	22	170	90	14	7.20
36	16	18/19	17	270	145	25	190	103	14	11.2
38	-	20	20.8	250	150	28	209	120	17	13.3
45	18/20	22	30	300	200	36	270	145	22	25.3
50	22	26	40	380	200	38	250	150	22	32.2
55	26	32	50	360	200	38	250	150	22	35.2
60	-	-	60	430	220	45	300	200	45	54.2
70	32	-	80	500	250	55	360	200	55	86
80	-	-	100	503	250	55	360	200	55	103

CAD INFO

\* could be delivered with a yellow or red finish



## Green Pin® Pear Shaped Link EN 1677-4 GR8

### Grade 8 pear shaped link EN 1677-4



MP

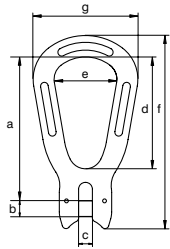

- **Material:** alloy steel, grade 8, quenched and tempered
- **Safety factor:** MBL equals 4 x WLL
- **Standard:** EN1677-1 and ASTM A952/952M
- **Finish:** painted yellow (J), red (R) or white
- **Temperature range:** -40 °C up to +200 °C
- **Certification:** 2.1 2.2 3.1 MTC<sup>a</sup> MPI<sup>b</sup> CE IIB
- **Article code:** scan QR code to see article codes
- **Note:** specific load pins available for 5, 7 and 9 mm hoist chain on request, which can be combined with respectively GPMP6, GPMP7/8, GPMP10

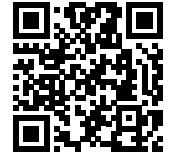

for chain diameter	working load limit	length	diameter pin	width	length inside	width inside	length	width outside	weight each
mm	t	a mm	b mm	c mm	d mm	e mm	f mm	g mm	kg
6	1.12	84	8	7	64	33	109	55	0.14
7/8	2	101	9	9	77	40	132	69	0.35
10	3.2	125	13	12	97	50	165	84	0.76
13	5.4	161	16	15	125	66	213	110	1.61
16	8.2	198	20	19	154	84	262	140	3.05
18/20	12.8	253	24	23	198	104	331	166	4.28

CAD INFO



## Green Pin® Omega Link EN 1677-1 GR8

### Grade 8 omega link EN 1677-1



CO

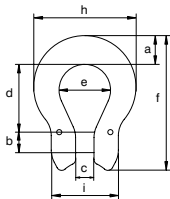

g



- **Material:** alloy steel, grade 8, quenched and tempered
- **Safety factor:** MBL equals 4 x WLL
- **Standard:** EN1677-1 and ASTM A952/952M
- **Finish:** painted white\*
- **Temperature range:** -40 °C up to +200 °C
- **Certification:** 2.1 2.2 3.1 MTC<sup>a</sup> MPI<sup>b</sup> DGUV CE IIB
- **Article code:** scan QR code to see article codes
- **Note:** specific load pins available for 5, 7 and 9 mm hoist chain on request, which can be combined with respectively GPCO6, GPCO7/8, GPCO10

for chain diameter	working load limit	width	diameter pin	width	length inside	width bow	length outside	thickness	width outside	width outside	thickness	weight each
mm	t	a mm	b mm	c mm	d mm	e mm	f mm	g mm	h mm	i mm	j mm	kg
6	1.12	14	8	7	25	20	53	13	41	28	6	0.07
7/8	2	20	9	9	34	24	71	16	55	32	9	0.20
10	3.2	19	13	12	40	31	82	17	63	42	11	0.28
13	5.4	25	16	15	51	40	106	20	84	54	14	0.64
16	8.2	32	20	19	64	48	132	25	104	68	17	1.28
18/20	12.8	38	24	23	80	59	163	30	126	82	22	2.25

CAD INFO

\* could be delivered with a yellow or red finish



## Green Pin® Connecting Link EN 1677-1 GR8

### Grade 8 connecting link EN 1677-1

Scan for additional product details

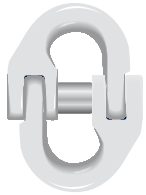
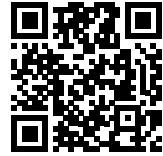

- **Material:** alloy steel, grade 8, quenched and tempered
- **Safety factor:** MBL equals 4 x WLL
- **Standard:** EN1677-1 and ASTM A952/952M
- **Finish:** painted white\*
- **Temperature range:** -40 °C up to +200 °C
- **Certification:** [2.1](#) [2.2](#) [3.1](#) [MTC<sup>a</sup>](#) [MPI<sup>b</sup>](#) [DGUV](#) [CE IIB](#)
- **Article code:** scan QR code to see article codes

MJ

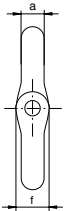
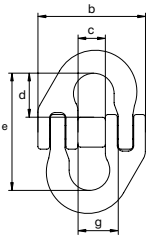

for chain diameter	working load limit	diameter	width outside	width inside	length inside	length inside	diameter eye	width inside	weight each
mm	t	a mm	b mm	c mm	d mm	e mm	f mm	g mm	kg
6	1.12	8	42	11	20	52	11	15	0.09
7/8	2	9	53	14	20	55	13	19	0.15
10	3.2	10	66	18	23	64	18	23	0.28
13	5.4	14	83	21	32	85	24	28	0.64
16	8.2	17	103	25	40	105	28	34	1.16
18/20	12.8	21	120	33	50	129	33	42	1.95
22	15.5	23	143	40	55	140	37	51	2.94
26	21.6	26	169	45	60	153	46	57	4.12
32	32.8	39	197	52	68	174	56	67	8.30

CAD INFO



## Green Pin® Lifting Chain EN818-2 GR8

### Grade 8 lifting chain

- **Material:** alloy steel, grade 8, quenched and tempered
- **Safety factor:** MBL equals 4 x WLL
- **Standard:** EN 818-2
- **Finish:** painted black
- **Temperature range:** -40 °C up to 200 °C
- **Certification:** [2.1](#) [2.2](#) [3.1](#) [MTC<sup>b</sup>](#) [DGUV](#) [CE IIB](#)
- **Article code:** scan QR code to see article codes



CHAIN

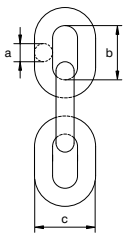

diameter	working load limit	length inside	width outside	links per meter	length per drum	weight per meter
a mm	t	b mm	c mm		m	kg
6	1.12	22	20	55.56	600	0.78
7	1.5	21	26	47.62	500	1.14
8	2	24	30	41.67	350	1.50
10	3.15	30	36	33.33	250	2.27
13	5.3	39	47	25.64	150	3.74
16	8	48	58	20.83	100	5.54
20	12.5	60	72	16.67	60	8.94
22	15	66	79	15.15	50	11.6
26	21.2	78	93	12.82	30	15.3
32	31.5	96	112	10.42	50	22.6

CAD

\* could be delivered with a yellow or red finish



## Green Pin® Grab Hook E EN 1677-1 GR8

### Grade 8 eye grab hook EN 1677-1

Scan for additional product details



CRO

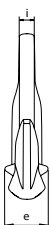
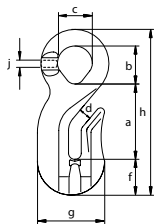

- **Material:** alloy steel, grade 8, quenched and tempered
- **Safety factor:** MBL equals 4 x WLL
- **Standard:** EN1677-1 and ASTM A952/A952M
- **Finish:** painted white\*
- **Temperature range:** -40 °C up to +200 °C
- **Certification:** 2.1 2.2 3.1 \*\* MTC<sup>a</sup> MPI<sup>b</sup> \*\* DGUV \*\* CE IIB
- **Article code:** scan QR code to see article codes

for chain diameter	working load limit	length	inside length eye	inside width eye	opening	thickness	width	width outside	length outside	width	thickness	weight each
mm	t	a mm	b mm	c mm	d mm	e mm	f mm	g mm	h mm	i mm	j mm	kg
6	1.12	41	24	23	8	24	20	42	94	9	6	0.24
7/8	2	53	27	27	10	33	23	53	115	10	8	0.33
10	3.2	67	38	36	12	42	39	66	158	14	10	0.91
13	5.4	84	42	42	15	56	40	87	186	16	12	2.02
16	8.2	104	53	52	19	65	58	106	236	17	16	2.49
20	12.8	130	37	37	22	75	48	128	241	26	26	6.28
22	15.5	120	44	44	25	77	57	132	247	26	26	6.09
26***	21.6	158	46	46	30	100	82	177	320	32	32	14.7
32***	32.8	210	57	57	38	91	88	215	395	39	39	18

\*\* Excluding sizes 20 mm, 22 mm, 26 mm and 32 mm

\*\*\* Different design

CAD

3.2



## Green Pin® Grab Hook CL EN 1677-1 GR8

### Grade 8 clevis grab hook EN 1677-1



CRC

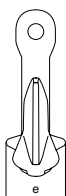
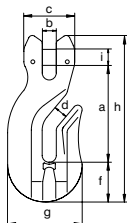

- **Material:** alloy steel, grade 8, quenched and tempered
- **Safety factor:** MBL equals 4 x WLL
- **Standard:** EN1677-1 and ASTM A952/A952M
- **Finish:** painted white\*
- **Temperature range:** -40 °C up to +200 °C
- **Certification:** 2.1 2.2 3.1 MTC<sup>a</sup> MPI<sup>b</sup> CE IIB
- **Article code:** scan QR code to see article codes

for chain diameter	working load limit	length	width	width outside	opening	thickness	width	width outside	length outside	diameter pin	weight each
mm	t	a mm	b mm	c mm	d mm	e mm	f mm	g mm	h mm	i mm	kg
6	1.12	52	7	28	8	24	19	42	85	8	0.23
7/8	2	64	9	33	10	33	23	53	103	9	0.45
10	3.2	89	11	42	12	42	39	66	151	13	1.05
13	5.4	103	15	54	15	56	40	78	173	16	2.05
16	8.2	120	18	67	19	65	58	106	214	20	3.03

CAD INFO

\* could be delivered with a yellow or red finish



## Green Pin® Shortening Clutch EN 1677-1 GR8

### Grade 8 shortening clutch EN 1677-1

Scan for additional product details

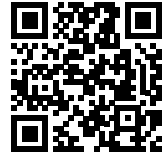

GC

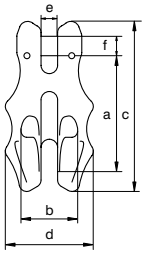

- **Material:** alloy steel, grade 8, quenched and tempered
- **Safety factor:** MBL equals 4 x WLL
- **Standard:** EN 1677-1, DIN 5692 and ASTM A952/A952M
- **Finish:** painted white\*
- **Temperature range:** -40 °C up to +200 °C
- **Certification:** [2.1](#) [2.2](#) [3.1](#) [MTC<sup>a</sup>](#) [MPI<sup>b</sup>](#) [DGUV](#) [CE IIB](#)
- **Article code:** scan QR code to see article codes

for chain diameter	working load limit	length	width inside	length	width outside	width	diameter pin	weight each
mm	t	a mm	b mm	c mm	d mm	e mm	f mm	kg
6	1.12	52	23	75	42	7	8	0.23
7/8	2	67	30	94	50	9	9	0.44
10	3.2	83	38	116	63	11	13	0.87
13	5.4	104	49	149	79	14	16	1.76
16	8.2	127	60	184	99	18	20	3.20
18/20	12.8	154	75	215	124	22	24	5.78

CAD INFO



## Green Pin® Shortening Clutch with Lock EN 1677-1 GR8

### Grade 8 shortening clutch with locking pin EN 1677-1

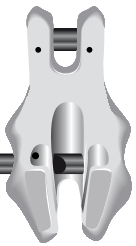

GCV

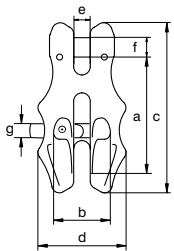

- **Material:** alloy steel, grade 8, quenched and tempered
- **Safety factor:** MBL equals 4 x WLL
- **Standard:** EN 1677-1, DIN 5692 and ASTM A952/A952M
- **Finish:** painted white\*
- **Temperature range:** -40 °C up to +200 °C
- **Certification:** [2.1](#) [2.2](#) [3.1](#) [MTC<sup>a</sup>](#) [MPI<sup>b</sup>](#) [DGUV](#) [CE IIB](#)
- **Article code:** scan QR code to see article codes

for chain diameter	working load limit	length	width inside	length	width outside	width	diameter pin	diameter pin	weight each
mm	t	a mm	b mm	c mm	d mm	e mm	f mm	g mm	kg
6	1.12	52	23	75	42	7	8	7	0.25
8	2	67	30	94	50	9	9	8	0.45
10	3.2	83	38	116	63	11	13	12	0.87
13	5.4	104	49	149	79	14	16	16	1.74
16	8.2	127	60	184	99	18	20	20	3.10
20	12.8	154	75	215	124	22	24	20	5.72

CAD INFO

\* could be delivered with a yellow or red finish

Scan for additional product details



## Green Pin® Shortening Clutch with Double Lock EN 1677-1 GR8

### Grade 8 shortening clutch with double locking pin EN 1677-1



GDV

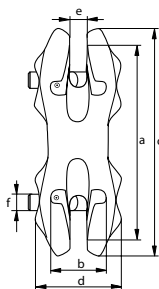

- **Material:** alloy steel, grade 8, quenched and tempered
- **Safety factor:** MBL equals 4 x WLL
- **Standard:** EN 1677-1, DIN 5692 and ASTM A952/A952M
- **Finish:** painted yellow (J), red (R) or white
- **Temperature range:** -40 °C up to +200 °C
- **Certification:** 2.1 2.2 3.1 MTC<sup>®</sup> MPI<sup>®</sup> DGVV CE IIA
- **Article code:** scan QR code to see article codes



for chain diameter	working load limit	length	width inside	length	width outside	width	diameter pin	weight each
mm	t	a mm	b mm	c mm	d mm	e mm	f mm	kg
6	1.12	99	23	120	42	7	7	0.49
8	2	112	30	140	50	9	8	0.77
13	5.4	178	49	208	79	15	16	2.85

CAD INFO



## Green Pin® Needle Bearing Swivel EE GR8

### Grade 8 needle bearing eye-eye swivel



ELR

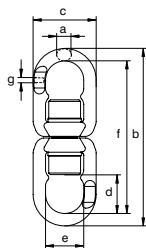

- **Material:** alloy steel, grade 8, quenched and tempered
- **Safety factor:** MBL equals 4 x WLL
- **Standard:** EN1677-1 and ASTM A952/A952M
- **Finish:** painted white\*
- **Temperature range:** -40 °C up to +200 °C
- **Certification:** 2.1 2.2 3.1 MTC<sup>®</sup> MPI<sup>®</sup> CE IIB
- **Article code:** scan QR code to see article codes
- **Note:** equipped with two thrust needle roller bearings to enable rotation under load



for chain diameter	working load limit	diameter	length outside	width outside	length inside	width inside	length	thickness	weight each
mm	t	a mm	b mm	c mm	d mm	e mm	f mm	g mm	kg
5/6	1.12	12	149	56	33	32	126	6	0.61
7/8	2	14	181	65	40	37	153	8	1.07
10	3.2	16	226	79	48	48	195	11	1.90
13	5.4	20	268	96	60	58	227	14	3.17
16	8.2	25	329	121	67	73	279	17	6.44
18/20	12.8	25	378	132	88	82	328	22	7.75

CAD

\* could be delivered with a yellow or red finish

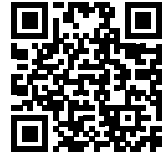

## Green Pin® Sling Hook E EN 1677-2 GR8

### Grade 8 eye sling hook EN 1677-2

- **Material:** alloy steel, grade 8, quenched and tempered
- **Safety factor:** MBL equals 4 x WLL
- **Standard:** EN1677-2 and ASTM A952/A952M
- **Finish:** painted white
- **Temperature range:** -40 °C up to +200 °C
- **Certification:** 2.1 2.2 3.1 \* MTC<sup>a</sup> MPI<sup>b</sup> \* DGUV \* CE IIB
- **Article code:** scan QR code to see article codes
- **Note:** from 8.2 t without flat part



CSO

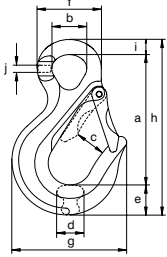

for chain diameter	working load limit	length	diameter inside eye	width opening	thickness	width	diameter eye outside	width outside	length outside	width	thickness	weight each
mm	t	a mm	b mm	c mm	d mm	e mm	f mm	g mm	h mm	i mm	j mm	kg
5/6	1.12	86	23	26	15	19	43	72	114	10	6	0.28
7/8	2	103	26	30	20	24	51	87	139	12	8	0.56
10	3.2	129	36	33	24	28	65	106	171	15	10	1.09
13	5.4	152	41	37	32	39	77	133	209	18	12	1.98
16	8.2	191	52	43	40	43	94	165	255	21	17	3.55
18/20	12.8	237	61	61	49	61	115	208	326	28	21	7.10
22	15.5	280	72	75	54	64	132	242	375	30	23	9.90
26**	21.6	251	48	73	55	86	111	236	363	32	32	13.3
32**	32.8	292	58	87	67	104	139	286	435	39	39	21.6

\* Excluding sizes 26 mm and 32 mm

\*\* Different design

CAD INFO



## Green Pin® Sling Hook CL EN 1677-2 GR8

### Grade 8 clevis sling hook EN 1677-2

- **Material:** alloy steel, grade 8, quenched and tempered
- **Safety factor:** MBL equals 4 x WLL
- **Standard:** EN1677-2 and ASTM A952/A952M
- **Finish:** painted white\*
- **Temperature range:** -40 °C up to +200 °C
- **Certification:** 2.1 2.2 3.1 MTC<sup>a</sup> MPI<sup>b</sup> DGUV CE IIB
- **Article code:** scan QR code to see article codes
- **Note:** specific load pins available for 5, 7 and 9 mm hoist chain on request, which can be combined with respectively GPCSC6, GPCSC7/8, GPCSC10



CSC

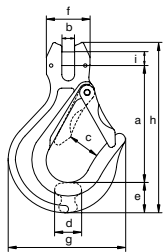

for chain diameter	working load limit	length	width	width opening	thickness	width	width outside	width outside	length outside	diameter pin	weight each
mm	t	a mm	b mm	c mm	d mm	e mm	f mm	g mm	h mm	i mm	kg
6	1.12	74	7	26	15	20	28	72	108	8	0.29
7/8	2	95	9	30	20	24	32	87	136	9	0.58
10	3.2	113	12	33	24	29	42	106	164	13	1.08
13	5.4	139	15	37	32	39	54	133	208	16	2.12
16	8.2	162	19	44	40	44	68	165	240	20	3.67
18/20	12.8	199	23	61	49	62	82	208	305	24	7.32
22	15.5	239	25	75	54	65	97	242	350	28	10.7

CAD INFO

\* could be delivered with a yellow or red finish

Scan for additional product details



## Green Pin® Sling Hook SE EN 1677-2 GR8

### Grade 8 swivel sling hook EN 1677-2

- **Material:** alloy steel, grade 8, quenched and tempered
- **Safety factor:** MBL equals 4 x WLL
- **Standard:** EN1677-2 and ASTM A952/A952M
- **Finish:** painted white\*
- **Temperature range:** -40 °C up to +200 °C
- **Certification:** 2.1 2.2 3.1 MTC<sup>a</sup> MPI<sup>b</sup> DGUV CE IIB
- **Article code:** scan QR code to see article codes
- **Note:** equipped with thrust needle roller bearing to enable rotation under load



CSE

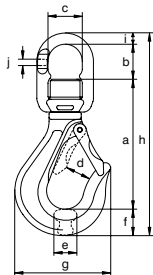

for chain diameter	working load limit	length	length inside	width inside	width opening	thickness	width	width outside	length outside	diameter	thickness	weight each
mm	t	a mm	b mm	c mm	d mm	e mm	f mm	g mm	h mm	i mm	j mm	kg
5/6	1.12	100	33	32	26	15	20	72	164	12	6	0.54
7/8	2	126	40	37	30	20	25	87	204	14	8	1
10	3.2	158	47	48	33	24	29	106	250	16	11	1.90
13	5.4	189	59	58	37	32	39	133	308	21	14	3.40
16	8.2	221	67	73	44	40	44	165	356	25	17	6.35
18/20	12.8	263	87	82	61	49	62	209	437	25	21	10.4

CAD INFO



## Green Pin® Sling Hook SCL EN 1677-2 GR8

### Grade 8 swivel sling hook with clevis EN 1677-2

- **Material:** alloy steel, grade 8, quenched and tempered
- **Safety factor:** MBL equals 4 x WLL
- **Standard:** EN1677-2 and ASTM A952/A952M
- **Finish:** painted yellow (J), red (R) or white
- **Temperature range:** -40 °C up to +200 °C
- **Certification:** 2.1 2.2 3.1 MTC<sup>a</sup> MPI<sup>b</sup> DGUV CE IIB
- **Article code:** scan QR code to see article codes
- **Note:** specific load pins available for 5, 7 and 9 mm hoist chain on request, which can be combined with respectively GPCSECA6, GPCSECA7/8, GPCSECA10 equipped with thrust needle roller bearing to enable rotation under load



CSECA

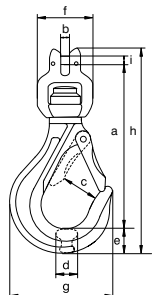

for chain diameter	working load limit	length	width	width opening	thickness	width	width outside	width outside	length	diameter pin	weight each
mm	t	a mm	b mm	c mm	d mm	e mm	f mm	g mm	h mm	i mm	kg
6	1.12	126	7	26	15	20	56	72	159	8	0.56
7/8	2	154	9	30	20	25	65	87	196	9	0.99
10	3.2	190	12	33	24	29	79	106	240	13	1.95
13	5.4	224	14	37	32	39	96	133	293	16	3.54
16	8.2	270	18	44	40	44	121	165	350	20	6.61

CAD INFO

\* could be delivered with a yellow or red finish



## Green Pin® Hook E GR8

### Grade 8 large eye hook with safety latch

Scan for additional product details



P-6714A

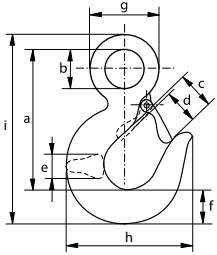

- **Material:** alloy steel, grade 8, quenched and tempered
- **Safety factor:** MBL equals 4 x WLL
- **Standard:** generally to EN 1677-2
- **Finish:** painted red
- **Temperature range:** -20 °C up to +200 °C
- **Certification:** 2.1 2.2 3.1 CE IIA
- **Article code:** scan QR code to see article codes

working load limit	length	diameter eye inside	opening hook	opening hook	thickness	width	diameter eye outside	width outside	length outside	weight each
t	a mm	b mm	c mm	d mm	e mm	f mm	g mm	h mm	i mm	kg
1.25	81	19	24	20	16	19	37	70	109	0.30
1.6	91	23	26	22	18	22	46	79	124	0.44
2.5	105	27	32	27	20	27	52	93	145	0.63
3.2	124	32	34	30	24	30	62	109	169	1.08
5.4	147	39	44	37	31	36	74	127	201	1.56
8.2	190	50	55	48	37	48	96	168	261	3.95
12.8	230	64	64	53	48	61	126	198	322	7.75
16	254	71	70	60	58	69	139	223	357	10.8
22	316	89	91	77	63	81	169	283	437	16.9

CAD

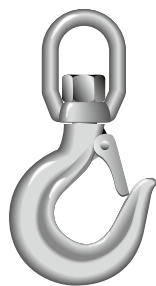

P-6703A

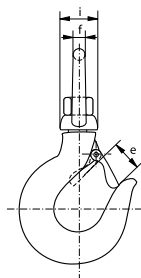
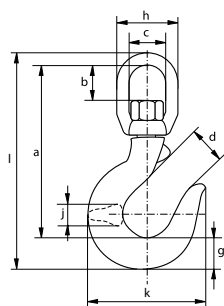

## Green Pin® Hook SE GR8

### Grade 8 swivel eye hook with safety latch

- **Material:** alloy steel, grade 8, quenched and tempered
- **Safety factor:** MBL equals 4 x WLL
- **Finish:** painted red
- **Temperature range:** -20 °C up to +200 °C
- **Certification:** 2.1 2.2 3.1 CE IIA
- **Article code:** scan QR code to see article codes



working load limit	length	length inside	width inside	opening hook	opening hook	diameter	width	width	width	thickness	width outside	length outside	weight each
t	a mm	b mm	c mm	d mm	e mm	f mm	g mm	h mm	i mm	j mm	k mm	l mm	kg
1.25	118	28	31	24	20	11	19	53	30	16	70	147	0.49
1.6	145	35	40	26	22	14	22	68	37	18	79	181	0.95
2.5	167	43	47	32	27	17	27	81	43	20	93	210	1.48
3.2	180	47	47	34	30	17	31	81	43	24	109	228	1.78
5.4	217	54	64	44	37	21	36	106	64	31	127	275	3.70
8.2	275	69	78	55	45	26	48	130	77	37	168	349	7.36
11.5	310	68	82	58	53	22	60	150	82	43	198	398	9.69
16	352	84	92	66	58	24	67	154	92	52	222	452	14.9
22	434	107	115	87	78	29	80	191	108	64	283	552	26
31.5	512	117	132	97	87	34	94	222	132	80	339	655	46

CAD



## Green Pin® Pipe Line Hook

Hook for handling cylindrical objects (pipes, tubes)

Scan for additional product details



P-6731

- **Material:** alloy steel, grade 8, quenched and tempered
- **Safety factor:** MBL equals 5 x WLL
- **Finish:** painted red
- **Temperature range:** -20 °C up to +200 °C
- **Certification:** 2.1 2.2 3.1 CE IIA
- **Article code:** scan QR code to see article codes

working load limit at hook		length	diameter eye inside	opening hook	diameter	thickness	diameter eye outside	width	weight each
top t	bottom t	a mm	b mm	c mm	d mm	e mm	f mm	g mm	kg
2	7.5	167	35	74	30	31	73	60	2.94

CAD

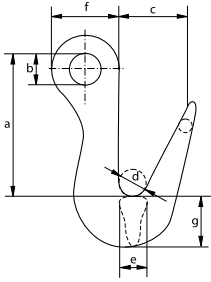



## Green Pin® Self Locking Hook E EN 1677-3 GR8

### Grade 8 eye self locking hook EN 1677-3

- **Material:** alloy steel, grade 8, quenched and tempered
- **Safety factor:** MBL equals 4 x WLL
- **Standard:** EN1677-3 and ASTM A952/A952M
- **Finish:** painted white\*
- **Temperature range:** -40 °C up to +200 °C
- **Certification:** 2.1 2.2 3.1 MTC<sup>a</sup> MPI<sup>b</sup> DGUV CE IIB
- **Article code:** scan QR code to see article codes
- **Note:** from 12.8 t without flat part



XLO

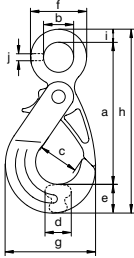

for chain diameter	working load limit	length	diameter inside eye	width opening	thickness	width	width outside	width outside	length	width	thickness	weight each
mm	t	a mm	b mm	c mm	d mm	e mm	f mm	g mm	h mm	i mm	j mm	kg
5/6	1.12	113	24	32	16	24	47	75	148	11	6	0.51
7/8	2	136	30	43	24	28	57	91	178	14	8	0.91
10	3.2	168	36	48	32	34	68	111	218	16	10	1.79
13	5.4	201	47	63	37	43	87	141	264	20	13	3.36
16	8.2	251	60	75	43	56	111	182	332	26	16	7
18/20	12.8	283	70	90	52	62	126	203	373	28	21	9.22

CAD INFO



## Green Pin® Self Locking Hook E GR8

### Grade 8 eye self locking hook

- **Material:** alloy steel, grade 8, quenched and tempered
- **Safety factor:** MBL equals 4 x WLL
- **Finish:** painted white\*
- **Temperature range:** -40 °C up to +200 °C
- **Certification:** 2.1 2.2 MTC<sup>a</sup> MPI<sup>b</sup> CE IIB
- **Article code:** scan QR code to see article codes



GKO

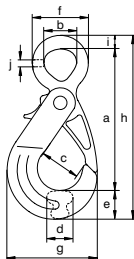

for chain diameter	working load limit	length	diameter inside eye	width opening	thickness	width	width outside	width outside	length	width	thickness	weight each
mm	t	a mm	b mm	c mm	d mm	e mm	f mm	g mm	h mm	i mm	j mm	kg
7/8	2	112	26	32	17	24	48	75	147	11	9	0.53
10	3.2	136	31	44	24	28	60	91	179	15	10	0.96
13	5.4	174	40	48	32	33	76	111	226	18	12	1.86
16	8.2	209	50	63	37	42	93	141	273	22	16	3.49
18/20	12.8	254	61	75	44	55	116	184	337	28	20	7.33
22	15.5	288	72	90	52	61	132	205	379	30	21	9.91

CAD INFO

\* could be delivered with a yellow or red finish



## Green Pin® Self Locking Hook CL EN 1677-3 GR8

### Grade 8 clevis self locking hook EN 1677-3

- **Material:** alloy steel, grade 8, quenched and tempered
- **Safety factor:** MBL equals 4 x WLL
- **Standard:** EN1677-3 and ASTM A952/A952M
- **Finish:** painted white\*
- **Temperature range:** -40 °C up to +200 °C
- **Certification:** 2.1 2.2 3.1 MTC<sup>a</sup> MPI<sup>b</sup> DGVV CE IIB
- **Article code:** scan QR code to see article codes
- **Note:** specific load pins available for 5, 7 and 9 mm hoist chain on request, which can be combined with respectively GPXLC0, GPXLC1, GPXLC2



XLC

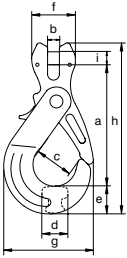

for chain diameter	working load limit	length	width	width opening	thickness	width	width outside	width outside	length	diameter pin	weight each
mm	t	a mm	b mm	c mm	d mm	e mm	f mm	g mm	h mm	i mm	kg
6	1.12	93	7	32	17	24	28	75	130	8	0.49
7/8	2	116	9	43	24	28	32	91	161	9	0.91
10	3.2	144	12	48	32	34	42	112	201	13	1.77
13	5.4	169	15	63	37	44	54	141	242	16	3.33
16	8.2	204	18	75	43	56	68	182	296	20	6.75
18/20	12.8	234	22	90	52	62	82	205	341	24	9.57

CAD INFO



## Green Pin® Self Locking Hook CL GR8

### Grade 8 clevis self locking hook

- **Material:** alloy steel, grade 8, quenched and tempered
- **Safety factor:** MBL equals 4 x WLL
- **Finish:** painted white\*
- **Temperature range:** -40 °C up to +200 °C
- **Certification:** 2.1 2.2 MTC<sup>a</sup> MPI<sup>b</sup> CE IIB
- **Article code:** scan QR code to see article codes
- **Note:** specific load pins available for 7 and 9 mm hoist chain on request, which can be combined with respectively GPGKC1, GPGKC2



GKC

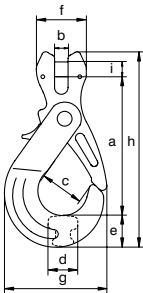

for chain diameter	working load limit	length	width	width opening	thickness	width	width outside	width outside	length	diameter pin	weight each
mm	t	a mm	b mm	c mm	d mm	e mm	f mm	g mm	h mm	i mm	kg
7/8	2	96	9	32	17	24	32	75	136	9	0.55
10	3.2	117	12	44	24	28	42	91	167	13	1.02
13	5.4	153	15	48	32	33	54	111	217	16	2.01
16	8.2	175	18	63	37	42	68	141	253	20	3.70
18/20	12.8	216	22	75	44	55	82	184	316	24	7.54
22	15.5	243	25	90	52	61	97	205	351	28	10.3

CAD INFO

\* could be delivered with a yellow or red finish



## Green Pin® Self Locking Hook SE EN 1677-3 GR8

### Grade 8 swivel self locking hook EN 1677-3



XLE

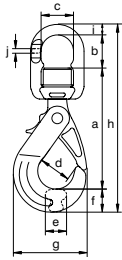

- **Material:** alloy steel, grade 8, quenched and tempered
- **Safety factor:** MBL equals 4 x WLL
- **Standard:** EN1677-3 and ASTM A952/A952M
- **Finish:** painted white\*
- **Temperature range:** -40 °C up to +200 °C
- **Certification:** 2.1 2.2 3.1 MTC<sup>a</sup> MPI<sup>b</sup> DGUV CE IIB
- **Article code:** scan QR code to see article codes
- **Note:** equipped with thrust needle roller bearing to enable rotation under load

for chain diameter	working load limit	length	length inside	width inside	width opening	thickness	width	width outside	length	diameter	thickness	weight each
mm	t	a mm	b mm	c mm	d mm	e mm	f mm	g mm	h mm	i mm	j mm	kg
5/6	1.12	123	33	32	32	16	24	75	191	12	6	0.78
7/8	2	149	41	37	43	24	28	91	232	14	8	1.39
10	3.2	186	47	48	48	32	34	112	283	16	11	2.56
13	5.4	214	60	58	63	37	44	141	337	21	14	4.56
16	8.2	273	67	73	75	43	56	182	420	25	17	9.50
18/20	12.8	304	87	82	90	52	62	205	478	25	22	12.7

CAD INFO



## Green Pin® Self Locking Hook SE GR8

### Grade 8 swivel self locking hook



GKE

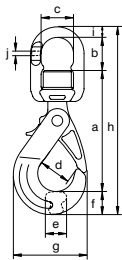

- **Material:** alloy steel, grade 8, quenched and tempered
- **Safety factor:** MBL equals 4 x WLL
- **Finish:** painted white\*
- **Temperature range:** -40 °C up to +200 °C
- **Certification:** 2.1 2.2 MTC<sup>a</sup> MPI<sup>b</sup> CE IIB
- **Article code:** scan QR code to see article codes
- **Note:** equipped with thrust needle roller bearing to enable rotation under load

for chain diameter	working load limit	length	length inside	width inside	width opening	thickness	width	width outside	length	diameter	thickness	weight each
mm	t	a mm	b mm	c mm	d mm	e mm	f mm	g mm	h mm	i mm	j mm	kg
7/8	2	123	33	32	32	17	24	75	191	12	6	0.77
10	3.2	149	41	37	44	24	28	91	231	14	8	1.38
13	5.4	186	47	48	48	32	33	111	282	16	11	2.56
16	8.2	214	60	58	63	37	42	141	336	21	14	4.58
18/20	12.8	272	67	73	75	45	55	184	418	25	17	9.51

CAD INFO

\* could be delivered with a yellow or red finish



# Green Pin® Self Locking Hook SCL EN 1677-3 GR8

## Grade 8 swivel clevis self locking hook EN 1677-3

Scan for additional product details



- **Material:** alloy steel, grade 8, quenched and tempered
- **Safety factor:** MBL equals 4 x WLL
- **Standard:** EN1677-3 and ASTM A952/A952M
- **Finish:** painted red (R) or white
- **Temperature range:** -40 °C up to +200 °C
- **Certification:** [2.1](#) [2.2](#) [3.1](#) [MTC<sup>a</sup>](#) [MPI<sup>b</sup>](#) [DGUV](#) [CE IIB](#)
- **Article code:** scan QR code to see article codes
- **Note:** specific load pins available for 5, 7 and 9 mm hoist chain on request, which can be combined with respectively GPXLBA0, GPXLBA1, GPXLBA2

XLBA

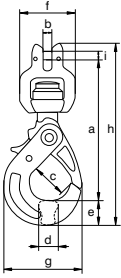

for chain diameter	working load limit	length	width	width opening	thickness	width	width outside	width outside	length	diameter pin	weight each
mm	t	a mm	b mm	c mm	d mm	e mm	f mm	g mm	h mm	i mm	kg
6	1.12	149	7	32	17	24	56	75	186	8	0.79
7/8	2	178	9	43	24	28	65	91	223	9	1.37
10	3.2	218	12	48	32	34	79	112	274	13	2.6
13	5.4	250	15	63	37	44	96	141	324	16	4.72
16	8.2	322	19	75	43	56	121	182	414	20	9.80

CAD INFO



GH

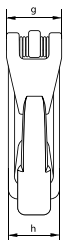
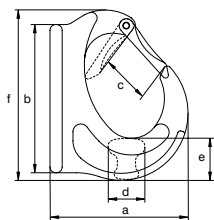

## Green Pin® Excavator Hook GR8

### Grade 8 excavator hook

- **Material:** alloy steel, grade 8, quenched and tempered
- **Safety factor:** MBL equals 4 x WLL
- **Standard:** EN1677-1
- **Finish:** painted white\*
- **Temperature range:** -40 °C up to +200 °C
- **Certification:** 2.1 2.2 3.1 MTC<sup>a</sup> MPI<sup>b</sup> CE IIA
- **Article code:** scan QR code to see article codes
- **Note:** welding must be done in accordance with DIN 5817 resp. 15429, by a qualified welder according to EN 287-1

Scan for additional product details



working load limit	width	length	width opening	thickness	width	length	width	width	weight each
t	a mm	b mm	c mm	d mm	e mm	f mm	g mm	h mm	kg
1	72	78	25	19	28	108	31	26	0.52
2	178	197	60	46	61	227	50	66	0.75
3	185	223	65	60	70	251	55	80	1.15
4	91	83	33	20	28	113	31	34	1.66
5	105	105	33	26	32	128	31	34	2.50
8	121	130	35	27	36	148	40	38	3.32
10	138	149	43	28	45	166	40	44	6.44
15	145	148	43	41	52	173	40	51	9.70

CAD INFO



CFO

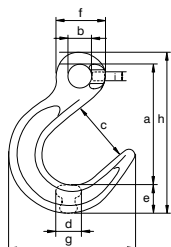

## Green Pin® Foundry Hook E GR8

### Grade 8 eye foundry hook

- **Material:** alloy steel, grade 8, quenched and tempered
- **Safety factor:** MBL equals 4 x WLL
- **Standard:** EN1677-1 and ASTM A952/A952M
- **Finish:** painted yellow (J), red (R) or white
- **Temperature range:** -40 °C up to +200 °C
- **Certification:** 2.1 2.2 3.1 \* MTC<sup>a</sup> \* MPI<sup>b</sup> \* DGUV \* CE IIB
- **Article code:** scan QR code to see article codes
- **Note:** from 8.2 t without flat part



for chain diameter	working load limit	length	diameter eye inside	width opening	thickness	width	diameter eye outside	width outside	length	thickness	weight each
mm	t	a mm	b mm	c mm	d mm	e mm	f mm	g mm	h mm	i mm	kg
6	1.12	93	19	48	17	21	38	97	124	7	0.33
7/8	2	125	25	64	22	28	50	129	165	9	0.78
10	3.2	157	34	79	27	35	65	161	208	11	1.50
13	5.4	190	44	95	35	45	84	198	254	13	3
16**	8.2	205	35	95	45	52	88	204	284	24	4.16
18/20**	12.8	235	40	111	53	55	92	228	315	25	7.80
22**	15.5	265	46	123	66	71	110	258	268	32	9.87
26**	21.6	305	54	133	65	81	120	277	420	33	13.8
32**	32.8	327	60	155	84	96	131	333	459	35	24.5

\* Excluding sizes 16 mm, 18/20 mm, 22 mm, 26 mm and 32 mm

\*\* Different design

\* could be delivered with a yellow or red finish

Scan for additional product details



## Green Pin® ID Tag

### Aluminium identification tag

- **Material:** aluminium
- **Finish:** see table below
- **Certification:** 2.1

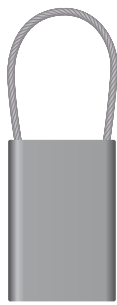

TAG

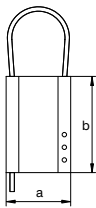

partnumber	finish	width	length	length	weight each
		a mm	b mm	c mm	
TAGVIERGE	self-coloured	51	76	220	0.07
TAGJ	anodized yellow	51	76	220	0.07
TAGGREEN	anodized green	51	76	220	0.07
TAGRED	anodized red	51	76	220	0.07
TAGBLUE	anodized blue	51	76	220	0.07
TAGDEMI	self-coloured	51	38	220	0.04
TAGB without wire rope	self-coloured	51	76		0.06

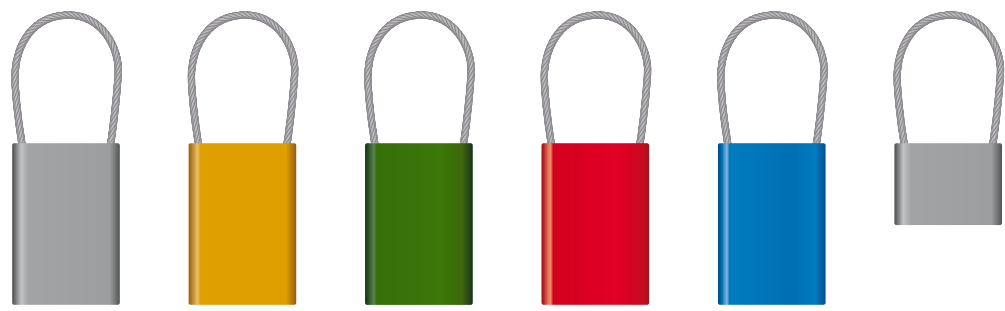

TAGVIERGE TAGJ TAGGREEN TAGRED TAGBLUE TAGDEMI

3.2



## Green Pin® ID Tag for Grade 8 Slings

### Forged identification tag for grade 8 slings

- **Material:** drop forged mild steel
- **Finish:** electro galvanized
- **Certification:** 2.1



TAGF

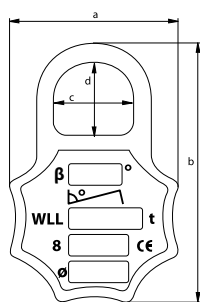

width	length	width inside	length inside	weight each
a mm	b mm	c mm	d mm	kg
75	115	35	32	0.28

RFID

Scan for additional product details



### Green Pin® RFID Tag

Accessory for radio-frequency identification of slings

- **Material:** stainless steel
- **Standard:** RF Protocol ISO 15693 Operating Frequency HF - 13.56 MHz with individual serial number
- **Finish:** polymer
- **Temperature range:** -40 °C up to +125 °C
- **Certification:** 2.1
- **Note:** IP68; water and ice proof

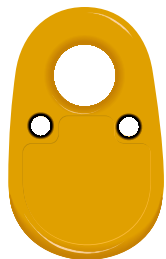

TAGRFID

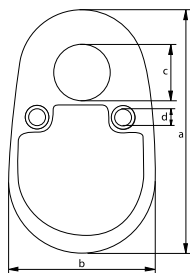

length	width	diameter	diameter	weight per 100 pcs
a mm	b mm	c mm	d mm	kg
53	33	12	4	1.80

RFID INFO

3.2



### Green Pin® RFID Chip

Accessory for radio-frequency identification of slings

- **Material:** polymer
- **Standard:** RF Protocol ISO 15693 Operating Frequency HF - 13.56 MHz with individual serial number
- **Temperature range:** -40 °C up to +125 °C
- **Certification:** 2.1
- **Note:** IP68; water and ice proof



CHIPRFID

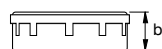
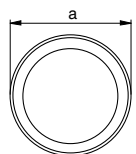

diameter	thickness	weight per 100 pcs
a mm	b mm	kg
6	2	0.02

RFID INFO



# Green Pin® Self Locking Hooks GR8/GR10 Spare Kit

## Replacement kit for grade 8 and 10 self locking hooks

- **Material:** steel
- **Finish:** self-coloured
- **Temperature range:** -40 °C up to +200 °C
- **Certification:** 2.1 CE IIB
- **Note:** plastic tube included, to make assembly easier

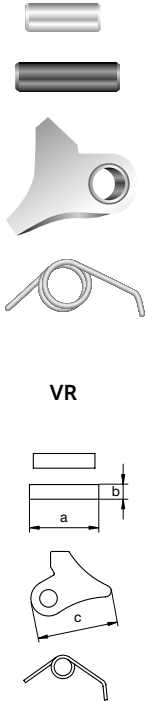

VR

partnumber	length pin	diameter pin	width	weight each
	a mm	b mm	c mm	kg
VR1	22	6	28	0.02
VR2	26	6	31	0.03
VR3	32	8	37	0.05
VR4	40	10	47	0.10
VR5	55	10	58	0.20

partnumber	for fitting							
	GKO	XLO	GKC	XLC	GKE	XLE	XLBA	XLS
VR1	GPGKO1	GPXLO0	GPGKC1	GPXLC0	GPGKE1	GPXLE0	GPXLBA0	
VR2	GPGKO2	GPXLO1	GPGKC2	GPXLC1	GPGKE2	GPXLE1	GPXLBA1	
VR3	GPGKO3	GPXLO2	GPGKC3	GPXLC2	GPGKE3	GPXLE2	GPXLBA2	GPXLS60
VR4	GPGKO4	GPXLO3	GPGKC4	GPXLC3	GPGKE4	GPXLE3	GPXLBA3	
VR5	GPGKO5	GPXLO4	GPGKC5	GPXLC4	GPGKE5	GPXLE4	GPXLBA4	
	GPGKO6	GPXLO5	GPGKC6	GPXLC5	GPGKE6	GPXLE5		

INFO

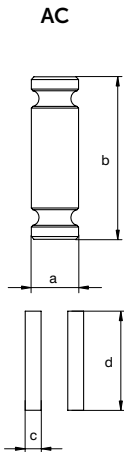
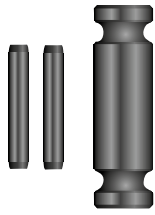

# Green Pin® Clevis Fittings GR8 Spare Kit

## Grade 8 spare kit for clevis fittings

- **Material:** alloy steel, grade 8, quenched and tempered
- **Finish:** self-coloured
- **Temperature range:** -40 °C up to +200 °C
- **Certification:** 2.1 3.1 CE IIB
- **Note:** GPAC5 is suitable for 6 mm clevis components and fits 5 mm hoist chain, GPAC7 is suitable for 8 mm clevis components and fits 7 mm hoist chain, GPAC9 is suitable for 10 mm clevis components and fits 9 mm hoist chain

partnumber	diameter pin	length pin	diameter pin	length pin	weight each
	a mm	b mm	c mm	d mm	kg
GPAC5	6	28	3	14	0.01
GPAC6	8	28	3	14	0.01
GPAC7	8	32	3	22	0.02
GPAC7/8	9	32	3	22	0.02
GPAC9	10	41	4	24	0.04
GPAC10	13	41	4	24	0.04
GPAC13	16	53	4	32	0.08
GPAC16	20	66	5	35	0.16
GPAC18/20	24	80	6	45	0.28
GPAC22	28	95	8	50	0.45

partnumber	for fitting									
	MP	CO	CSC	CSECA	XLC	GKC	GC	GCV	CRC	XLBA
GPAC5	GPMP5	GPCO5	GPCSC5	GPCSECA5	GPXLC05		GPGC5	GPGCV5		GPXLBA05
GPAC6	GPMP6	GPCO6	GPCSC6	GPCSECA6	GPXLC0		GPGC6	GPGCV6	GPCRC6	GPXLBA0
GPAC7	GPMP7/8	GPCO7/8	GPCSC7/8	GPCSECA7/8	GPXLC1	GPGKC1	GPGC7/8		GPCRC7/8	GPXLBA1
GPAC7/8	GPMP7/8	GPCO7/8	GPCSC7/8	GPCSECA7/8	GPXLC1	GPGKC1	GPGC7/8	GPGCV8	GPCRC7/8	GPXLBA1
GPAC9	GPMP10	GPCO10	GPCSC10	GPCSECA10	GPXLC2	GPGKC2	GPGC10	GPGCV10	GPCRC10	GPXLBA2
GPAC10	GPMP10	GPCO10	GPCSC10	GPCSECA10	GPXLC2	GPGKC2	GPGC10	GPGCV10	GPCRC10	GPXLBA2
GPAC13	GPMP13	GPCO13	GPCSC13	GPCSECA13	GPXLC3	GPGKC3	GPGC13	GPGCV13	GPCRC13	GPXLBA3
GPAC16	GPMP16	GPCO16	GPCSC16	GPCSECA16	GPXLC4	GPGKC4	GPGC16	GPGCV16	GPCRC16	GPXLBA4
GPAC18/20	GPMP18/20	GPCO18/20	GPCSC18/20		GPXLC5	GPGKC5	GPGC18/20	GPGCV20		
GPAC22			GPCSC22			GPGKC6				

INFO



# Green Pin® Connecting Link Spare Kit GR8

## Grade 8 spare kit for connecting link

- **Material:** alloy steel, grade 8, quenched and tempered
- **Finish:** self-coloured
- **Temperature range:** -40 °C up to +200 °C
- **Certification:** 2.1 3.1 CE IIB

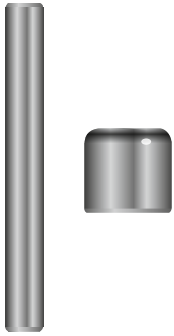

RMJ

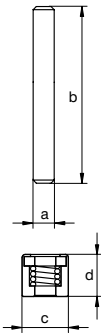

partnumber	diameter pin	length pin	diameter	width	weight each
	a mm	b mm	c mm	d mm	kg
GPRMJ6	5	41	12	10	0.01
GPRMJ7/8	6	54	13	14	0.02
GPRMJ10	8	66	16	18	0.04
GPRMJ13	10	84	22	22	0.10
GPRMJ16	12	105	25	25	0.15
GPRMJ18/20	15	122	28	32	0.25
GPRMJ22	17	141	32	35	0.38
GPRMJ26	20	169	38	40	0.54
GPRMJ32	22	199	45	50	1

partnumber	for fitting	
	MJ	MJS
GPRMJ6	GPMJ6	
GPRMJ7/8	GPMJ7/8	GPMJS7/8
GPRMJ10	GPMJ10	GPMJS10
GPRMJ13	GPMJ13	GPMJS13
GPRMJ16	GPMJ16	
GPRMJ18/20	GPMJ18/20	
GPRMJ22	GPMJ22	
GPRMJ26	GPMJ26	
GPRMJ32	GPMJ32	

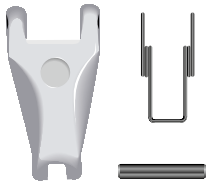

LF

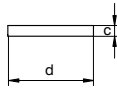
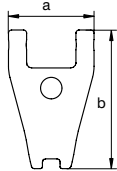

## Green Pin® Latch GR8

### Forged latch for grade 8

- **Material:** steel
- **Finish:** painted white\*, GPLF8 is self-coloured
- **Temperature range:** -40 °C up to +200 °C
- **Certification:** 2.1 CE IIB

partnumber	width	length	diameter pin	length pin	weight each
	a mm	b mm	c mm	d mm	kg
GPLF0	24	44	4	24	0.03
GPLF1	31	59	5	30	0.07
GPLF2	41	65	5	40	0.11
GPLF3	41	79	6	40	0.18
GPLF4	46	81	6	45	0.22
GPLF5	50	100	8	50	0.33
GPLF6	55	119	10	55	0.55
GPLF8	60	141	8	74	0.34

partnumber	for fitting					
	CSO	CSC	CSE	CSECA	GH	CST
GPLF0	GPCSO5/6	GPCSC5	GPCSE5/6	GPCSECA5		
		GPCSC6		GPCSECA6		
GPLF1	GPCSO7/8	GPCSC7/8	GPCSE7/8	GPCSECA7/8	GPGH1-GPGH2-GPGH3	GPCST75
GPLF2	GPCSO10	GPCSC10	GPCSE10	GPCSECA10	GPGH4	
GPLF3	GPCSO13	GPCSC13	GPCSE13	GPCSECA13	GPGH5 - GPGH8	
GPLF4	GPCSO16	GPCSC16	GPCSE16	GPCSECA16		
GPLF5	GPCSO18/20	GPCSC18/20	GPCSE18/20		GPGH10	
GPLF6	GPCSO22	GPCSC22			GPGH15	
GPLF8	GPCSO26 - GPCSO32					

INFO

\* could be delivered with a yellow or red finish



# Green Pin® Clevis For Web Sling Connector GR8 Spare Kit

## Grade 8 spare kit for clevis for web sling connector

- **Material:** alloy steel, grade 8, quenched and tempered
- **Finish:** self-coloured
- **Temperature range:** -40 °C up to +200 °C
- **Certification:** 2.1 3.1 CE IIB

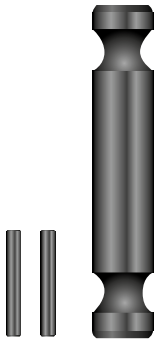

RCOS

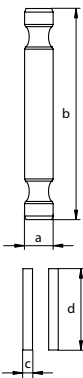

partnumber	diameter pin	length pin	diameter pin	length pin	weight each
	a mm	b mm	c mm	d mm	kg
GPRCOS7/8	9	58	3	22	0.03
GPRCOS10	13	74	4	24	0.08
GPRCOS13	16	94	4	32	0.15
GPRCOS16	20	116	5	35	0.25

partnumber	for fitting	
	COS	XLS
GPRCOS7/8	GPCOS60	
GPRCOS10	GPCOS90	
GPRCOS13	GPCOS150	GPXLS60
GPRCOS16	GPCOS240	

LIFTING SLING FITTINGS

# FOR GRADE 10 CHAIN



## Applications

Green Pin® grade 10 lifting sling fittings enable the assembly of a complete sling from the top master link to the hook, with a 25 % WLL higher than grade 8.

For specific product information the following product groups can be found on the mentioned page:































Top links					
					
<b>UMS</b> page 180	<b>UMTS</b> page 181	<b>UMSW</b> page 182	<b>UMTSW</b> page 183		
Connectors					
					
<b>UMP</b> page 184	<b>UCO</b> page 184	<b>UMJ</b> page 185			
Chain					
					
<b>UCHAIN</b> page 185					

Table continues on next page

Shorteners					
					
<b>UCRO</b> page 186	<b>UCRC</b> page 186	<b>UGC</b> page 187	<b>UGCV</b> page 187	<b>UGDV</b> page 188	
End-fittings					
					
<b>UELRL</b> page 189	<b>UCSO</b> page 190	<b>UCSC</b> page 190	<b>UXLO</b> page 191	<b>UXLORT</b> page 191	<b>UXLC</b> page 192
					
<b>UXLCRT</b> page 192	<b>UXLE</b> page 193	<b>UXLERT</b> page 193	<b>UCFO</b> page 194		
Accessories					
					
<b>TAG</b> page 195	<b>UTAGF</b> page 195	<b>TAGRFID</b> page 196	<b>CHIPRFID</b> page 196	<b>VR</b> page 197	<b>VRRT</b> page 197
					
<b>UAC</b> page 198	<b>URMJ</b> page 198	<b>ULF</b> page 199			

## Range

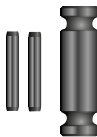
Green Pin® supplies a range of grade 10 lifting sling fittings generally from 6 mm to 20 mm chain diameters.

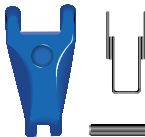
Below lifting sling fittings can be found:

- Links, e.g. Green Pin® Master Link, Connecting Link
- Chain, e.g. Green Pin® Lifting Chain Grade 10
- Swivel, e.g. Green Pin® Needle Bearing Swivel Eye-Eye
- Hooks, e.g. Green Pin® Sling Hook, Self Locking Hook

## Design

Grade 10 lifting sling fittings has **up to 25% higher load capacity than grade 8** lifting sling fittings. Connecting links and lifting sling fittings with clevis connection are supplied unassembled and ready for immediate use. Assembly is quick and easy.

Master links, eye hooks, eye swivels are generally supplied with a flat part for easy connection to the sling or for easy assembly with the omega link.

There are different types of hooks with specific designs to suit various purposes.

### Hooks attachment options to sling:

- Hook with an eye at the top
- Hook with a swivel eye at the top
- Hook with a clevis at the top

### Hook designs:

- Self-locking hook
- Self-locking hook with a recessed trigger
- Sling hook
- Grab hook
- Foundry hook

Chain slings can be shortened by using a grab hook or a shortening clutch.

### Grade 10 lifting sling fittings are generally marked with:

- manufacturer's symbol - e.g. GP
- size in mm and/ or inch - e.g. 13 and/or 1/2"
- traceability code - e.g. HA
- steel grade - e.g. 10
- item code (specific products) - e.g. UMJ
- origin (specific products) - e.g. France
- DGUV certified (specific products) - e.g. H94

As prescribed by the Machinery Directive 2006/42/EC our hooks, master links and connecting links are supplied with a CE Declaration of Incorporation (CE IIB), stating the products are in compliance with the requirements of the machinery directive. These products do not have a CE marking, since CE markings are only to be provided for machines, whereas hooks, master links and connecting links are components of machines, and not machines themselves. Providing components with a CE marking is an incorrect interpretation of the Machinery Directive.

Machinery definition according to Machinery Directive 2006/42/EC – Article 2 – definitions (a) and Machinery Regulation 2023/1230/EU:

"An assembly of linked parts or components, at least one of which moves and which are joined together, intended for lifting loads and whose only power source is directly applied human effort."

"The maximum working load shall be prominently marked on the lifting machinery. The marking shall be legible, indelible and in an un-coded form. Where the maximum working load depends on the configuration of the lifting machinery, each operating position shall be provided with a load plate indicating, preferably in diagrammatic form or by means of tables, the working load permitted for each configuration."

This definition means that a sling is a Machine and that the hooks, master links and connecting links are not considered as a machine themselves, but as components of a machine. The CE and the WLL markings in consequence, are mandatory only on the assembled sling tag as the sling is the machine according to MD 2006/42/EC. This rule is still valid with the new Machine Regulation 2023/1230 which will replace the MD cited previously within early 2027.

## Finish

All grade 10 lifting sling fittings are painted. Grade 10 lifting sling fittings under the Green Pin® brand are painted blue.

## Certification

Specific details of certificate availability can be found on each product page. Please verify your certification requirements with Green Pin® at the time of order.

## Instructions for use

Grade 10 lifting sling fittings, should be inspected before use to ensure that:

- all markings are legible.
- all lifting sling fittings of the complete sling are made of the same steel grade 10.
- a lifting sling fitting with the correct WLL has been selected with respect to the sling design.  
For further details, refer to the EN 818-4 with values for grade 10 and ASME B30.9 standard for Chain Slings.
- the pin, bolt, nut, bush or any other locking system cannot move or vibrate out of position.
- lifting sling fittings are free from nicks, gouges, and cracks.
- lifting sling fittings are not heat treated, modified, repaired or reshaped by machining or bent.  
(This may affect their Working Load Limit).
- lifting sling fittings items are not distorted or unduly worn. (Maximum allowable wear is 10 % of the original diameter)
- the latch of the hook(s) is present and functional.
- the hook is never side-, tip- or back- loaded.
- the hook is supporting the load correctly.
- the latch should not be supporting any load.
- only use the lifting sling fittings for in-line lifting.

Grade 10 lifting sling fittings must be regularly inspected in accordance with the safety standards given in the country of use. This is required because the products in use may be affected by issues such as wear, misuse, and overloading, which may lead to deformation and alteration of the material structure. Inspection should take place at least every six months (follow the local rules in the country of use), and more frequently when the links are used in severe operating conditions.

## Testing

Generally load rated products are proof load and MPI tested.

For specific information on certificates we refer to the separate paragraph on certification.

Green Pin® grade 10 lifting sling fittings are proof load tested at the following loads:

for chain diameter	Working Load Limit (WLL)	Proofload (PL)
mm	t	t
6	1.4	3.5
7	1.95	4.88
8	2.6	6.5
10	4	10
13	6.8	17
16	10.3	25.75
20	16	40



## Temperature

If extreme temperature situations occur, the following load reductions must be taken into account:

Temperature °Celsius	Temperature °Fahrenheit	Reduction for elevated temperatures New Working Load Limit
-40 °C up to 200 °C	-40 °F up to 392 °F	100 % of original WLL
200 - 300 °C	392 - 572 °F	90 % of original WLL
300 - 400 °C	572 - 752 °F	75 % of original WLL
> 400 °C	> 752 °F	not allowed

Note: Grade 10 lifting chain, designation UCHAIN temperature range is -40 °C up to +200 °C. This chain cannot be used above +200 °C.

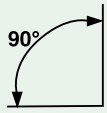
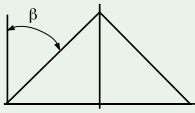
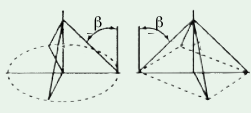
**Working Load Limit table for Grade 10 Chain Slings to EN 818-4 with values for grade 10**

Chain Ø						
	1 leg sling	2 leg sling		3 or 4 leg sling		Endless Sling
	90°	0° < β ≤ 45° Safety factor 1.4	45° < β ≤ 60° Safety factor 1.0	0° < β ≤ 45° Safety factor 2.1	45° < β ≤ 60° Safety factor 1.5	Safety factor 1.6
mm	t	t	t	t	t	t
6	1.4	1.95	1.40	2.95	2.10	2.24
8	2.6	3.69	2.60	5.50	3.90	4.16
10	4	5.65	4.00	8.50	6.00	6.40
13	6.8	9.60	6.80	14.20	10.20	10.88
16	10.3	14.50	10.30	21.80	15.45	16.48
20	16	22.40	16.00	33.60	24.00	25.60
22	19	26.50	19.00	40.00	28.00	30.40

When using multi leg slings make sure that the angles between the lifting points and sling legs are within the range marked on the sling. The angle β, which is the angle between the sling leg and the vertical, should never exceed 60°.

### Symmetry of loading

The WLL values mentioned have been determined are based on symmetrical loading of the sling. This means that when the load is lifted, the sling legs are symmetrically distributed in the plane and all legs of the sling have the same angles to the vertical. For more details on chain slings refer to EN 818-6:2000+A1:2008.

The loading can be assumed to be symmetric if all the following conditions are met:

- the load is less than 80 % of marked WLL and
- sling leg angles to the vertical are all more than 15° and
- sling leg angles to the vertical are all within 15° to each other and
- in the case of three- and four- leg slings, the plane angles are within 15° of each other.

If one of the above parameters is not met, the loading should be considered to be asymmetric, and the lift should be referred to a competent engineer to establish the safe rating for the sling. Alternatively, in the case of asymmetric loading, the sling should be derated to half the marked WLL. If the load tends to tilt during the lift, it should be lowered, and the attachments changed by repositioning the attachment points or by using compatible shortening devices. The safety factor of 4 on the individual components is designed for safety only. Never exceed the indicated WLL.

Use the below reduction table if a multi leg sling is not used for the purpose for which it has been designed, for example for a lifting operation with fewer legs than the number of legs of the sling:

Types of chain sling	Number of legs used	Factor to apply to marked WLL
Two-leg	1	1/2
Three- and four-leg	2	2/3
Three- and four-leg	1	1/3

Examples of do's and don'ts



A hook cannot be used as a clamp.

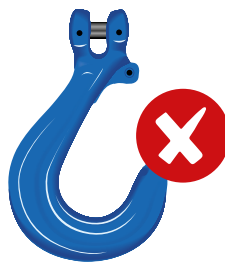

Don't use hooks without latch, as an exception is the foundry hook.



Hook body and latch may not be bent. This is a sign the hook is overloaded.

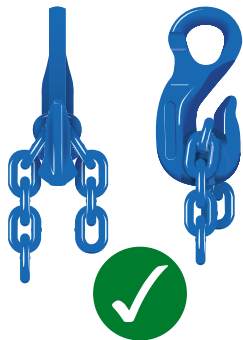

Position the chain properly in the throat.

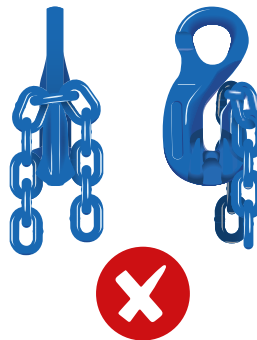

Do not tip load hooks.



Correct positioned or mounted



Wrong applied

Load (F) bearing chain always needs to be at the bottom of the shortening clutch.



UMS

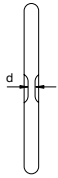
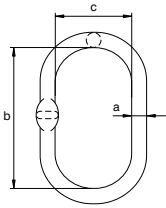

## Green Pin® Master Link GR10

### Grade 10 master link

- **Material:** alloy steel, grade 10, quenched and tempered
- **Safety factor:** MBL equals 4 x WLL
- **Standard:** follows the EN1677 with grade 10 values and conforms to ASTM A952/A952M and ASME B30.9
- **Finish:** painted blue
- **Temperature range:** -40 °C up to +200 °C
- **Certification:** 2.1 2.2 3.1 MTC<sup>®</sup> MPI<sup>®</sup> CE IIB
- **Article code:** scan QR code to see article codes

Scan for additional product details



diameter	diameter chain 1 leg	diameter chain 2 legs		working load limit	length inside	width inside	thickness	weight each
a mm	mm	$\beta \leq 45^\circ$ mm	$45^\circ < \beta \leq 60^\circ$ mm	t	b mm	c mm	d mm	kg
13	6	6	6	2	115	60	7	0.40
16	8	-	8	3.2	120	70	7	0.60
18	10	8	10	5.4	135	75	9	0.84
22	13	10	13	8.2	170	90	11	1.60
25	16	13	16	11.2	190	103	14	2.17
30	18/20	16	18/20	16	235	125	17	4
38	22	20/22	22	27.6	250	150	22	7.10

CAD



# Green Pin® Master Link Assembly GR10

## Grade 10 master link assembly



- **Material:** alloy steel, grade 10, quenched and tempered
- **Safety factor:** MBL equals 4 x WLL
- **Standard:** follows the EN1677 with grade 10 values and conforms to ASTM A952/A952M and ASME B30.9
- **Finish:** painted blue
- **Temperature range:** -40 °C up to +200 °C
- **Certification:** 2.1 2.2 3.1 MTC<sup>b</sup> MPI<sup>a</sup> CE IIB
- **Article code:** scan QR code to see article codes

UMTS

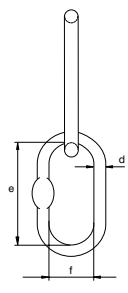
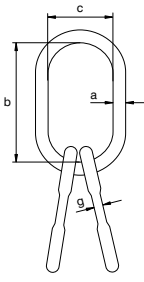

diameter	diameter chain 3/4 legs		working load limit	length inside	width inside	diameter	length inside	width inside	thickness	weight each
a mm	$\beta \leq 45^\circ$ mm	$45^\circ < \beta \leq 60^\circ$ mm	t	b mm	c mm	d mm	e mm	f mm	g mm	kg
18	6	6	3.65	135	75	16	120	70	7	1.97
22	8	8/10	6.8	170	90	18	135	75	9	3.30
28	10	13	11	209	120	20	150	82	11	5.40
36	13	16	17.7	270	145	25	190	103	14	11.2
38	16	18/19	21.2	250	150	30	235	125	17	15.1
50	20	22	41.6	380	200	38	250	150	22	32.2

CAD



UMSW

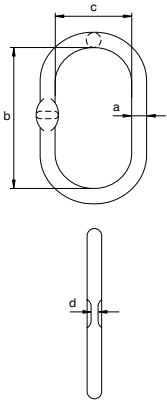

## Green Pin® Wider Master Link GR10

### Grade 10 wider master link

- **Material:** alloy steel, grade 10, quenched and tempered
- **Safety factor:** MBL equals 5 x WLL
- **Standard:** follows the EN1677 with grade 10 values and conforms to ASTM A952/A952M and ASME B30.9
- **Finish:** painted blue
- **Temperature range:** -40 °C up to +200 °C
- **Certification:** 2.1 2.2 3.1 MTC<sup>®</sup> MPI<sup>®</sup> CE IIB
- **Article code:** scan QR code to see article codes

Scan for additional product details



working load limit	diameter	length inside	width inside	thickness	weight each
t	a mm	b mm	c mm	d mm	kg
4.1	17	160	90	9	0.85
6.7	19	160	90	9	1.08
11.5	25	210	115	13	2.43
17	33	270	140	17	5.40
27.7	38	275	150	21	7.50
45	50	380	200	50	17.7
64	56	400	200	56	23.5

CAD



# Green Pin® Wider Master Link Assembly GR10

## Grade 10 wider master link assembly

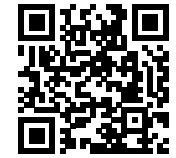

- **Material:** alloy steel, grade 10, quenched and tempered
- **Safety factor:** MBL equals 5 x WLL
- **Standard:** follows the EN1677 with grade 10 values and conforms to ASTM A952/A952M and ASME B30.9
- **Finish:** painted blue
- **Temperature range:** -40 °C up to +200 °C
- **Certification:** 2.1 2.2 3.1 MTC<sup>b</sup> MPI<sup>a</sup> CE IIB
- **Article code:** scan QR code to see article codes

UMTSW

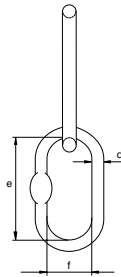
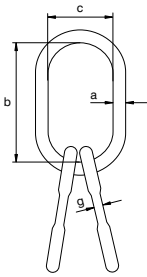

working load limit	diameter	length inside	width inside	diameter	length inside	width inside	thickness	weight each
t	a mm	b mm	c mm	d mm	e mm	f mm	g mm	kg
4.3	19	160	90	14	120	70	9	1.96
6.7	23	180	100	17	160	90	9	3.50
28.1	40	300	160	33	270	140	17	19.8
38.3	45	340	180	38	275	150	21	27.8
75	60	400	200	50	380	200	50	62.5

CAD



## Green Pin® Pear Shaped Link GR10

### Grade 10 pear shaped link

- **Material:** alloy steel, grade 10, quenched and tempered
- **Safety factor:** MBL equals 4 x WLL
- **Standard:** follows the EN1677 with grade 10 values and conforms to ASTM A952/A952M
- **Finish:** painted blue
- **Temperature range:** -40 °C up to +200 °C
- **Certification:** 2.1 2.2 3.1 MTC<sup>®</sup> MPI<sup>®</sup> CE IIB
- **Article code:** scan QR code to see article codes

Scan for additional product details



UMP

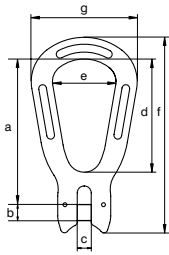

for chain diameter	working load limit	length	diameter pin	width	length inside	width inside	length	width outside	weight each
mm	t	a mm	b mm	c mm	d mm	e mm	f mm	g mm	kg
6	1.4	84	8	7	64	33	109	55	0.14
7	1.95	100	10	9	77	40	132	69	0.28
8	2.6	100	10	9	77	40	132	69	0.28
10	4	125	13	12	97	50	165	84	0.63
13	6.8	161	16	15	125	66	213	110	1.40
16	10.3	198	20	19	154	84	262	140	2.73

CAD INFO



## Green Pin® Omega Link GR10

### Grade 10 omega link

- **Material:** alloy steel, grade 10, quenched and tempered
- **Safety factor:** MBL equals 4 x WLL
- **Standard:** follows the EN1677 with grade 10 values and conforms to ASTM A952/A952M
- **Finish:** painted blue
- **Temperature range:** -40 °C up to +200 °C
- **Certification:** 2.1 2.2 3.1 MTC<sup>®</sup> MPI<sup>®</sup> DGVV CE IIB
- **Article code:** scan QR code to see article codes



UCO

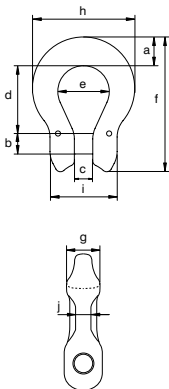

for chain diameter	working load limit	width	diameter pin	width	length inside	width bow	length outside	thickness	width outside	width outside	thickness	weight each
mm	t	a mm	b mm	c mm	d mm	e mm	f mm	g mm	h mm	i mm	j mm	kg
6	1.4	14	8	7	25	20	53	13	41	28	6	0.07
7	1.95	21	10	9	34	24	72	16	58	32	9	0.18
8	2.6	21	10	9	34	24	72	16	58	32	9	0.18
10	4	21	13	12	40	31	84	19	67	42	11	0.28
13	6.8	28	16	15	51	40	109	23	90	54	14	0.64
16	10.3	35	20	19	64	48	135	27	110	68	17	1.21

CAD INFO



## Green Pin® Connecting Link GR10

### Grade 10 connecting link

- **Material:** alloy steel, grade 10, quenched and tempered
- **Safety factor:** MBL equals 4 x WLL
- **Standard:** follows the EN1677 with grade 10 values and conforms to ASTM A952/A952M
- **Finish:** painted blue
- **Temperature range:** -40 °C up to +200 °C
- **Certification:** 2.1 2.2 3.1 MTC<sup>a</sup> MPI<sup>b</sup> DGUV CE IIB
- **Article code:** scan QR code to see article codes

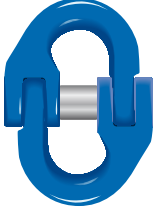

UMJ

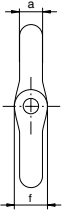
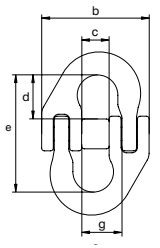

for chain diameter	working load limit	diameter	width outside	width inside	length inside	length inside	diameter eye	width inside	weight each
mm	t	a mm	b mm	c mm	d mm	e mm	f mm	g mm	kg
6	1.4	8	42	11	20	52	11	15	0.09
7	1.95	9	53	14	20	55	16	19	0.18
8	2.6	9	53	14	20	55	16	19	0.18
10	4	12	66	18	23	64	18	23	0.31
13	6.8	16	83	21	32	85	24	28	0.68
16	10.3	19	105	25	40	105	28	34	1.27
20	16	23	122	33	49	128	38	42	2.27

CAD INFO



## Green Pin® Lifting Chain GR10

### Grade 10 lifting chain

- **Material:** alloy steel, grade 10, quenched and tempered
- **Safety factor:** MBL equals 4 x WLL
- **Standard:** follows the EN818-2 with grade 10 values
- **Finish:** painted blue
- **Temperature range:** -40 °C up to 200 °C
- **Certification:** 2.1 2.2 3.1 MTC<sup>a</sup> CE IIB
- **Article code:** scan QR code to see article codes



UCHAIN

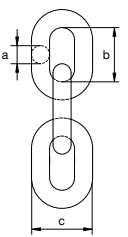

diameter	working load limit	length inside	width outside	links per meter	length per drum	weight per meter
a mm	t	b mm	c mm		m	kg
6	1.4	18	22	55.56	200	0.80
8	2.6	24	30	41.67	200	1.50
10	4	30	36	33.33	200	2.30
13	6.8	39	48	25.64	100	3.90
16	10.3	48	58	20.83	100	5.80
20	16	60	72	16.67	50	8.90

CAD



UCRO

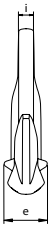
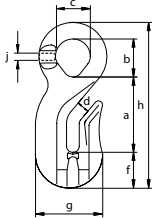

## Green Pin® Grab Hook E GR10

### Grade 10 eye grab hook

- **Material:** alloy steel, grade 10, quenched and tempered
- **Safety factor:** MBL equals 4 x WLL
- **Standard:** follows the EN1677 with grade 10 values and conforms to ASTM A952/A952M
- **Finish:** painted blue
- **Temperature range:** -40 °C up to +200 °C
- **Certification:** 2.1 2.2 3.1 MTC<sup>®</sup> MPI<sup>®</sup> CE IIB
- **Article code:** scan QR code to see article codes



for chain diameter	working load limit	length	inside length eye	inside width eye	opening	thickness	width	width outside	length outside	width	thickness	weight each
mm	t	a mm	b mm	c mm	d mm	e mm	f mm	g mm	h mm	i mm	j mm	kg
6	1.4	41	24	23	8	24	20	42	94	9	6	0.24
7/8	2.6	53	27	27	10	37	28	53	120	10	8	0.51
10	4	67	38	36	12	42	39	66	158	14	10	1.08
13	6.8	84	42	42	15	56	40	87	186	16	12	2
16	10.3	104	53	52	19	65	58	106	236	17	16	2.49

CAD



UCRC

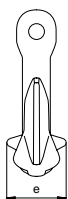
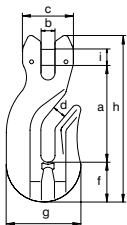

## Green Pin® Grab Hook CL GR10

### Grade 10 clevis grab hook

- **Material:** alloy steel, grade 10, quenched and tempered
- **Safety factor:** MBL equals 4 x WLL
- **Standard:** follows the EN1677 with grade 10 values and conforms to ASTM A952/A952M
- **Finish:** painted blue
- **Temperature range:** -40 °C up to +200 °C
- **Certification:** 2.1 2.2 3.1 MTC<sup>®</sup> MPI<sup>®</sup> CE IIB
- **Article code:** scan QR code to see article codes



for chain diameter	working load limit	length	width	width outside	opening	thickness	width	width outside	length outside	diameter pin	weight each
mm	t	a mm	b mm	c mm	d mm	e mm	f mm	g mm	h mm	i mm	kg
6	1.4	52	7	28	8	24	25	42	91	8	0.35
7	1.95	64	9	32	10	37	28	53	108	10	0.35
8	2.6	64	9	32	10	37	28	53	108	10	0.35
10	4	89	11	42	12	42	39	66	151	13	1.06
13	6.8	103	15	54	15	56	40	87	173	16	1.70
16	10.3	120	18	67	19	65	58	106	214	20	3.76

CAD INFO

Scan for additional product details



## Green Pin® Shortening Clutch GR10

### Grade 10 shorting clutch with locking pin

- **Material:** alloy steel, grade 10, quenched and tempered
- **Safety factor:** MBL equals 4 x WLL
- **Standard:** follows the EN1677 with grade 10 values and conforms to ASTM A952/A952M
- **Finish:** painted blue
- **Temperature range:** -40 °C up to +200 °C
- **Certification:** 2.1 2.2 3.1 MTC<sup>a</sup> MPI<sup>b</sup> DGUV CE IIB
- **Article code:** scan QR code to see article codes



UGC

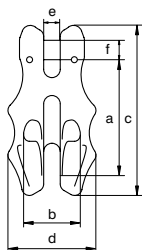

for chain diameter	working load limit	length	width inside	length	width outside	width	diameter pin	weight each
mm	t	a mm	b mm	c mm	d mm	e mm	f mm	kg
6	1.4	52	23	75	42	7	8	0.23
7	1.95	67	30	94	50	9	10	0.45
8	2.6	67	30	94	50	9	10	0.45
10	4	83	38	116	63	11	13	0.90
13	6.8	104	49	149	79	14	16	1.78
16	10.3	127	60	184	99	18	20	3.20
20	16	154	75	215	124	22	24	5.78

CAD INFO



## Green Pin® Shortening Clutch with Lock GR10

### Grade 10 shortening clutch with locking pin

- **Material:** alloy steel, grade 10, quenched and tempered
- **Safety factor:** MBL equals 4 x WLL
- **Standard:** follows the EN1677 and DIN5692 with grade 10 values and ASTM A952/A952M
- **Finish:** painted blue
- **Temperature range:** -40 °C up to +200 °C
- **Certification:** 2.1 2.2 3.1 MTC<sup>a</sup> MPI<sup>b</sup> DGUV CE IIB
- **Article code:** scan QR code to see article codes

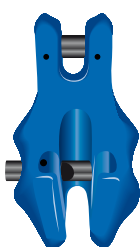

UGCV

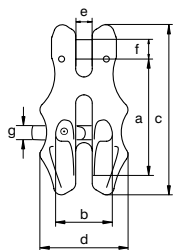

for chain diameter	working load limit	length	width inside	length	width outside	width	diameter pin	diameter pin	weight each
mm	t	a mm	b mm	c mm	d mm	e mm	f mm	g mm	kg
6	1.4	52	23	75	42	7	8	7	0.23
8	2.6	67	30	94	50	9	10	8	0.44
10	4	83	38	116	63	11	13	12	0.87
13	6.8	104	49	149	79	14	16	16	1.67
16	10.3	127	60	184	99	18	20	20	3.10
20	16	154	75	215	124	22	24	20	5.80

CAD INFO





UGDV

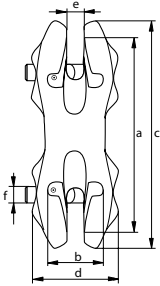

## Green Pin® Shortening Clutch with Double Lock GR10

### Grade 10 shortening clutch with double locking pin

- **Material:** alloy steel, grade 10, quenched and tempered
- **Safety factor:** MBL equals 4 x WLL
- **Standard:** follows the EN1677 with grade 10 values and conforms to ASTM A952/A952M
- **Finish:** painted blue
- **Temperature range:** -40 °C up to +200 °C
- **Certification:** 2.1 2.2 3.1 MTC<sup>a</sup> MPI<sup>b</sup> DGUV CE IIA
- **Article code:** scan QR code to see article codes

Scan for  
additional  
product  
details



for chain diameter	working load limit	length	width inside	length	width outside	width	diameter pin	weight each
mm	t	a mm	b mm	c mm	d mm	e mm	f mm	kg
6	1.4	100	23	120	42	7	7	0.49
8	2.6	112	30	140	50	9	8	0.77
13	6.8	180	49	208	79	15	16	2.85

CAD INFO



# Green Pin® Needle Bearing Swivel EE GR10

## Grade 10 needle bearing eye-eye swivel

Scan for additional product details



- **Material:** alloy steel, grade 10, quenched and tempered
- **Safety factor:** MBL equals 4 x WLL
- **Standard:** follows the EN1677 with grade 10 values and conforms to ASTM A952/A952M
- **Finish:** painted blue
- **Temperature range:** -40 °C up to +200 °C
- **Certification:** 2.1 2.2 3.1 MTC<sup>a</sup> MPI<sup>b</sup> CE IIB
- **Article code:** scan QR code to see article codes
- **Note:** equipped with two thrust needle roller bearings to enable rotation under load

UCLR

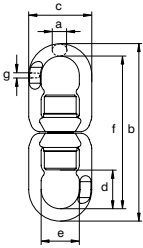

for chain diameter	working load limit	diameter	length outside	width outside	length inside	width inside	length	thickness	weight each
mm	t	a mm	b mm	c mm	d mm	e mm	f mm	g mm	kg
6	1.4	12	149	56	33	32	126	6	0.61
7/8	2.6	14	181	65	40	37	153	8	1.07
10	4	16	226	79	48	48	195	11	1.90
13	6.8	20	268	96	60	58	227	14	3.17
16	10.3	25	329	121	67	73	279	17	6.44
20	16	25	378	132	88	82	328	22	7.75

CAD



UCSO

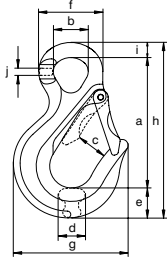

## Green Pin® Sling Hook E GR10

### Grade 10 eye sling hook

- **Material:** alloy steel, grade 10, quenched and tempered
- **Safety factor:** MBL equals 4 x WLL
- **Standard:** follows the EN1677 with grade 10 values and conforms to ASTM A952/A952M
- **Finish:** painted blue
- **Temperature range:** -40 °C up to +200 °C
- **Certification:** 2.1 2.2 3.1 MTC<sup>®</sup> MPI<sup>®</sup> DGVV CE IIB
- **Article code:** scan QR code to see article codes
- **Note:** from 10 t without flat part



for chain diameter	working load limit	length	diameter inside eye	width opening	thickness	width	diameter eye outside	width outside	length	width	thickness	weight each
mm	t	a mm	b mm	c mm	d mm	e mm	f mm	g mm	h mm	i mm	j mm	kg
6	1.4	86	23	26	15	19	43	73	114	10	6	0.28
7/8	2.6	103	26	30	19	24	51	87	139	12	8	0.52
10	4	129	36	33	24	28	65	106	171	15	10	1.09
13	6.8	152	41	37	32	39	77	133	209	18	12	1.94
16	10.3	191	52	43	40	43	94	165	255	21	17	3.51
20	16	237	61	61	49	61	115	208	326	28	21	7.08

CAD INFO



UCSC

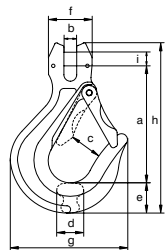

## Green Pin® Sling Hook CL GR10

### Grade 10 clevis sling hook

- **Material:** alloy steel, grade 10, quenched and tempered
- **Safety factor:** MBL equals 4 x WLL
- **Standard:** follows the EN1677 with grade 10 values and conforms to ASTM A952/A952M
- **Finish:** painted blue
- **Temperature range:** -40 °C up to +200 °C
- **Certification:** 2.1 2.2 3.1 MTC<sup>®</sup> MPI<sup>®</sup> DGVV CE IIB
- **Article code:** scan QR code to see article codes



for chain diameter	working load limit	length	width	width opening	thickness	width	width outside	width outside	length outside	diameter pin	weight each
mm	t	a mm	b mm	c mm	d mm	e mm	f mm	g mm	h mm	i mm	kg
6	1.4	74	7	26	15	20	28	72	108	8	0.29
7	1.95	95	9	30	20	24	32	87	136	9	0.58
8	2.6	95	9	30	20	24	32	87	136	9	0.58
10	4	113	11	33	24	29	42	106	164	13	1.11
13	6.8	139	15	37	32	39	54	133	208	16	2.12
16	10.3	162	18	44	40	44	68	165	240	20	3.78
20	16	199	23	61	49	62	82	208	305	24	7.49

CAD INFO



## Green Pin® Self Locking Hook E GR10

### Grade 10 eye self locking hook



- **Material:** alloy steel, grade 10, quenched and tempered
- **Safety factor:** MBL equals 4 x WLL
- **Standard:** follows the EN1677 with grade 10 values and conforms to ASTM A952/A952M
- **Finish:** painted blue
- **Temperature range:** -40 °C up to +200 °C
- **Certification:** 2.1 2.2 3.1 MTC<sup>a</sup> MPI<sup>b</sup> DGVV CE IIB
- **Article code:** scan QR code to see article codes

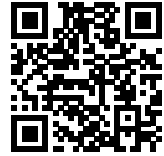

UXLO

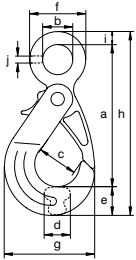

for chain diameter	working load limit	length	diameter inside eye	width opening	thickness	width	width outside	width outside	length	width	thickness	weight each
mm	t	a mm	b mm	c mm	d mm	e mm	f mm	g mm	h mm	i mm	j mm	kg
6	1.4	113	24	32	16	24	47	75	148	11	6	0.51
7/8	2.6	136	30	43	24	28	57	91	178	14	8	0.91
10	4	168	36	48	32	34	68	110	218	16	10	1.79
13	6.8	201	47	63	37	43	87	141	264	20	13	3.36
16	10.3	251	60	75	43	56	111	182	332	26	16	7
20	16	283	70	90	52	62	126	203	373	28	21	9.22

CAD INFO



## Green Pin® Self Locking Hook E RT GR10

### Grade 10 eye self locking hook with recessed trigger



- **Material:** alloy steel, grade 10, quenched and tempered
- **Safety factor:** MBL equals 4 x WLL
- **Standard:** follows the EN1677 with grade 10 values and conforms to ASTM A952/A952M
- **Finish:** painted blue
- **Temperature range:** -40 °C up to +200 °C
- **Certification:** 2.1 2.2 3.1 MTC<sup>a</sup> MPI<sup>b</sup> DGVV CE IIB
- **Article code:** scan QR code to see article codes

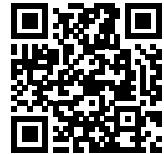

UXLORT

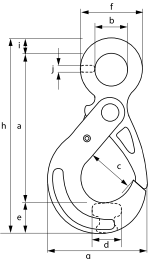

for chain diameter	working load limit	length	diameter inside eye	width opening	thickness	width	width outside	width outside	length	width	thickness	weight each
mm	t	a mm	b mm	c mm	d mm	e mm	f mm	g mm	h mm	i mm	j mm	kg
7/8	2.6	136	30	43	24	28	57	91	178	14	7	0.90
10	4	168	36	48	32	34	68	111	218	16	10	1.77
13	6.8	201	47	63	37	43	87	141	264	20	13	3.34
16	10.3	251	60	75	43	56	111	182	332	26	16	6.98
20	16	283	70	90	52	62	126	203	373	28	20	9.20

CAD INFO



## Green Pin® Self Locking Hook CL GR10

### Grade 10 clevis self locking hook



- **Material:** alloy steel, grade 10, quenched and tempered
- **Safety factor:** MBL equals 4 x WLL
- **Standard:** follows the EN1677 with grade 10 values and conforms to ASTM A952/A952M
- **Finish:** painted blue
- **Temperature range:** -40 °C up to +200 °C
- **Certification:** 2.1 2.2 3.1 MTC<sup>®</sup> MPI<sup>®</sup> DGVV CE IIB
- **Article code:** scan QR code to see article codes



UXLC

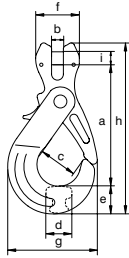

for chain diameter	working load limit	length	width	width opening	thickness	width	width outside	width outside	length	diameter pin	weight each
mm	t	a mm	b mm	c mm	d mm	e mm	f mm	g mm	h mm	i mm	kg
6	1.4	93	7	32	17	24	28	75	130	8	0.49
7	1.95	116	9	43	24	28	32	91	161	10	0.91
8	2.6	116	9	43	24	28	32	91	161	10	0.91
10	4	144	11	48	32	34	42	112	201	13	1.74
13	6.8	169	15	63	37	44	54	141	242	16	3.33
16	10.3	204	18	75	43	56	68	182	296	20	6.75
20	16	234	22	90	52	62	82	205	341	24	9.57

CAD INFO



## Green Pin® Self Locking Hook CL RT GR10

### Grade 10 clevis self locking hook with recessed trigger



- **Material:** alloy steel, grade 10, quenched and tempered
- **Safety factor:** MBL equals 4 x WLL
- **Standard:** follows the EN1677 with grade 10 values and conforms to ASTM A952/A952M
- **Finish:** painted blue
- **Temperature range:** -40 °C up to +200 °C
- **Certification:** 2.1 2.2 3.1 MTC<sup>®</sup> MPI<sup>®</sup> DGVV CE IIB
- **Article code:** scan QR code to see article codes



UXLCRT

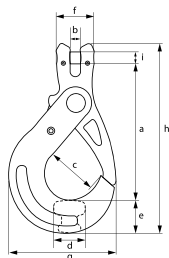

for chain diameter	working load limit	length	width	width opening	thickness	width	width outside	width outside	length	diameter pin	weight each
mm	t	a mm	b mm	c mm	d mm	e mm	f mm	g mm	h mm	i mm	kg
7	1.95	116	9	43	24	28	32	91	161	10	0.90
8	2.6	116	9	43	24	28	32	91	161	10	0.90
10	4	144	12	48	32	34	42	112	201	13	1.72
13	6.8	169	15	63	37	44	54	141	242	16	3.31
16	10.3	204	19	75	43	56	68	182	296	20	6.73
20	16	234	23	90	52	62	82	205	341	24	9.55

CAD INFO



## Green Pin® Self Locking Hook SE GR10

### Grade 10 swivel self locking hook

- **Material:** alloy steel, grade 10, quenched and tempered
- **Safety factor:** MBL equals 4 x WLL
- **Standard:** follows the EN1677 with grade 10 values and conforms to ASTM A952/A952M
- **Finish:** painted blue
- **Temperature range:** -40 °C up to +200 °C
- **Certification:** [2.1](#) [2.2](#) [3.1](#) [MTC<sup>a</sup>](#) [MPI<sup>b</sup>](#) [DGUV](#) [CE IIB](#)
- **Article code:** scan QR code to see article codes
- **Note:** equipped with thrust needle roller bearings to enable rotation under load

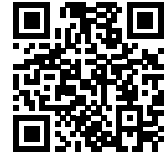

UXLE

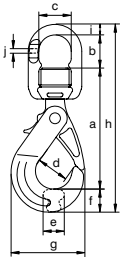

for chain diameter	working load limit	length	length inside	width inside	width opening	thickness	width	width outside	length	diameter	thickness	weight each
mm	t	a mm	b mm	c mm	d mm	e mm	f mm	g mm	h mm	i mm	j mm	kg
6	1.4	123	33	32	32	17	24	75	191	12	6	0.78
7/8	2.6	149	41	37	43	24	28	91	232	14	8	1.39
10	4	186	47	48	48	32	34	112	283	16	11	2.56
13	6.8	214	60	58	63	37	44	141	337	21	14	4.56
16	10.3	273	67	73	75	43	56	182	420	25	17	9.50
20	16	304	87	82	90	52	62	205	478	25	22	12.4

CAD INFO



## Green Pin® Self Locking Hook SE RT GR10

### Grade 10 swivel self locking hook with recessed trigger

- **Material:** alloy steel, grade 10, quenched and tempered
- **Safety factor:** MBL equals 4 x WLL
- **Standard:** follows the EN1677 with grade 10 values and conforms to ASTM A952/A952M
- **Finish:** painted blue
- **Temperature range:** -40 °C up to +200 °C
- **Certification:** [2.1](#) [2.2](#) [3.1](#) [MTC<sup>a</sup>](#) [MPI<sup>b</sup>](#) [DGUV](#) [CE IIB](#)
- **Article code:** scan QR code to see article codes
- **Note:** equipped with thrust needle roller bearings to enable rotation under load



UXLERT

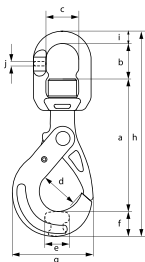

for chain diameter	working load limit	length	length inside	width inside	width opening	thickness	width	width outside	length	diameter	thickness	weight each
mm	t	a mm	b mm	c mm	d mm	e mm	f mm	g mm	h mm	i mm	j mm	kg
7/8	2.6	149	41	37	43	24	28	91	232	14	8	1.38
10	4	186	47	48	48	32	34	112	283	16	11	2.54
13	6.8	214	60	58	63	37	44	141	337	21	14	4.54
16	10.3	273	67	73	75	43	56	182	420	25	17	9.48
20	16	304	87	82	90	52	62	205	478	25	21	12.4

CAD INFO



UCFO

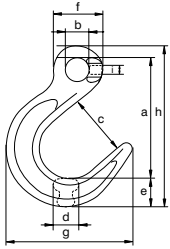

## Green Pin® Foundry Hook E GR10

### Grade 10 eye foundry hook

- **Material:** alloy steel, grade 10, quenched and tempered
- **Safety factor:** MBL equals 4 x WLL
- **Standard:** follows the EN1677 with grade 10 values and conforms to ASTM A952/A952M
- **Finish:** painted blue
- **Temperature range:** -40 °C up to +200 °C
- **Certification:** 2.1 2.2 3.1 MTC<sup>®</sup> MPI<sup>®</sup> DGVV CE IIB
- **Article code:** scan QR code to see article codes



for chain diameter	working load limit	length	diameter eye inside	width opening	thickness	width	diameter eye outside	width outside	length	thickness	weight each
mm	t	a mm	b mm	c mm	d mm	e mm	f mm	g mm	h mm	i mm	kg
6	1.4	93	19	48	17	21	38	97	124	7	0.33
7/8	2.6	125	25	64	22	28	50	129	165	9	0.78
10	4	157	34	79	28	35	65	161	208	11	1.50
13	6.8	190	44	95	35	45	84	198	255	13	3

Scan for additional product details



## Green Pin® ID Tag

### Aluminium identification tag

- **Material:** aluminium
- **Finish:** see table below
- **Certification:** 2.1



TAG

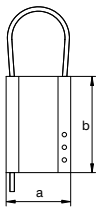

partnumber	finish	width	length	length	weight each
		a mm	b mm	c mm	
TAGVIERGE	self-coloured	51	76	220	0.07
TAGJ	anodized yellow	51	76	220	0.07
TAGGREEN	anodized green	51	76	220	0.07
TAGRED	anodized red	51	76	220	0.07
TAGBLUE	anodized blue	51	76	220	0.07
TAGDEMI	self-coloured	51	38	220	0.04
TAGB without wire rope	self-coloured	51	76		0.06

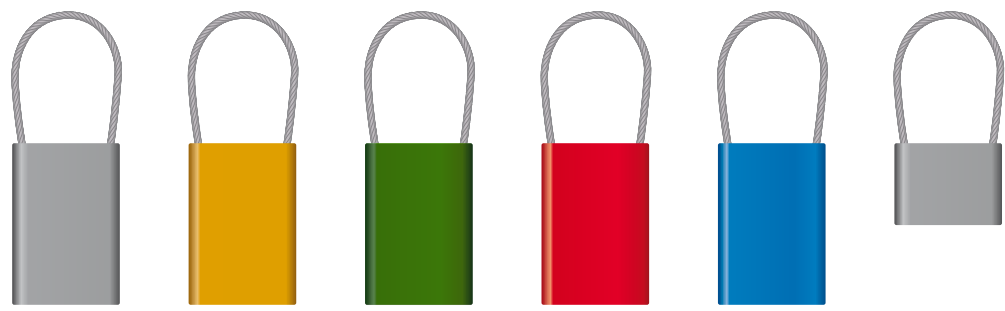

TAGVIERGE

TAGJ

TAGGREEN

TAGRED

TAGBLUE

TAGDEMI



## Green Pin® ID Tag for Grade 10 Slings

### Forged identification tag for grade 10 slings

- **Material:** drop forged mild steel
- **Finish:** electro galvanized
- **Certification:** 2.1



UTAGF

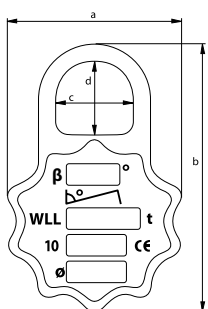

width	length	width inside	length inside	weight each
a mm	b mm	c mm	d mm	kg
79	121	35	32	0.30

RFID



## Green Pin® RFID Tag

### Accessory for radio-frequency identification of slings

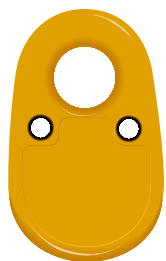

TAGRFID

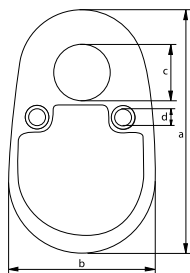

- **Material:** stainless steel
- **Standard:** RF Protocol ISO 15693 Operating Frequency HF - 13.56 MHz with individual serial number
- **Finish:** polymer
- **Temperature range:** -40 °C up to +125 °C
- **Certification:** 2.1
- **Note:** IP68; water and ice proof

length	width	diameter	diameter	weight per 100 pcs
a mm	b mm	c mm	d mm	kg
53	33	12	4	1.80

RFID INFO



## Green Pin® RFID Chip

### Accessory for radio-frequency identification of slings



CHIPRFID

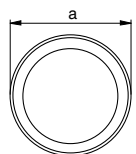

- **Material:** polymer
- **Standard:** RF Protocol ISO 15693 Operating Frequency HF - 13.56 MHz with individual serial number
- **Temperature range:** -40 °C up to +125 °C
- **Certification:** 2.1
- **Note:** IP68; water and ice proof

diameter	thickness	weight per 100 pcs
a mm	b mm	kg
6	2	0.02

RFID INFO



## Green Pin® Self Locking Hooks GR8/GR10 Spare Kit

Replacement kit for grade 8 and 10 self locking hooks

- **Material:** steel
- **Finish:** self-coloured
- **Temperature range:** -40 °C up to +200 °C
- **Certification:** 2.1 CE IIB
- **Note:** plastic tube included, to make assembly easier



VR

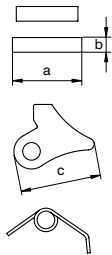

partnumber	length pin	diameter pin	width	weight each
	a mm	b mm	c mm	kg
VR1	22	6	28	0.02
VR2	26	6	31	0.03
VR3	32	8	37	0.05
VR4	40	10	47	0.10
VR5	55	10	58	0.20

partnumber	for fitting		
	UXLO	UXLC	UXLE
VR1	GPUXLO0	GPUXLC0	GPUXLE0
VR2	GPUXLO1	GPUXLC07	GPUXLE1
		GPUXLC1	
VR3	GPUXLO2	GPUXLC2	GPUXLE2
VR4	GPUXLO3	GPUXLC3	GPUXLE3
VR5	GPUXLO4	GPUXLC4	GPUXLE4
	GPUXLO5	GPUXLC5	GPUXLE5

INFO



## Green Pin® Self Locking Hooks RT GR10 Spare Kit

Replacement kit for grade 8 and 10 self locking hooks with recessed trigger

- **Material:** steel
- **Finish:** self-coloured
- **Temperature range:** -40 °C up to +200 °C
- **Certification:** 2.1 CE IIB
- **Note:** plastic tube included, to make assembly easier



VRRT

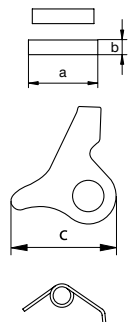

partnumber	length pin	diameter pin	width	weight each
	a mm	b mm	c mm	kg
GPVR2RT	26	6	31	0.03
GPVR3RT	32	8	37	0.05
GPVR4RT	40	10	47	0.10
GPVR5RT	55	10	58	0.20

partnumber	for fitting		
	UXLORT	UXLCRT	UXLERT
GPVR2RT	GPUXLO1RT	GPUXLC1RT	GPUXLE1RT
GPVR3RT	GPUXLO2RT	GPUXLC2RT	GPUXLE2RT
GPVR4RT	GPUXLO3RT	GPUXLC3RT	GPUXLE3RT
GPVR5RT	GPUXLO4RT	GPUXLC4RT	GPUXLE4RT
	GPUXLO5RT	GPUXLC5RT	GPUXLE5RT

INFO



## Green Pin® Clevis Fittings GR10 Spare Kit

### Grade 10 spare kit for clevis fittings

- **Material:** alloy steel, grade 10, quenched and tempered
- **Finish:** self-coloured
- **Temperature range:** -40 °C up to +200 °C
- **Certification:** 2.1 3.1 CE IIB

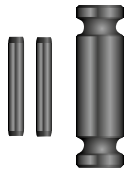

UAC

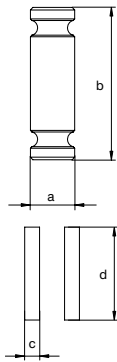

partnumber	diameter pin	length pin	diameter pin	length pin	weight each
	a mm	b mm	c mm	d mm	kg
GPUAC6	8	28	3	14	0.01
GPUAC7	10	32	3	22	0.02
GPUAC8	10	32	3	22	0.02
GPUAC10	13	41	4	24	0.04
GPUAC13	16	53	4	30	0.08
GPUAC16	20	66	5	35	0.16
GPUAC20	24	80	6	45	0.28

partnumber	for fitting						
	UMP	UCO	UCSC	UXLC	UGC	UGCV	UXLCRT
GPUAC6	GPUMP6	GPUCO6	GPUCSC6	GPUXLC0	GPUGC6	GPUGCV6	
GPUAC7	GPUMP7	GPUCO7	GPUCSC7	GPUXLC07	GPUGC7		GPUXLC07RT
GPUAC8	GPUMP8	GPUCO8	GPUCSC8	GPUXLC1	GPUGC8	GPUGCV8	GPUXLC1RT
GPUAC10	GPUMP10	GPUCO10	GPUCSC10	GPUXLC2	GPUGC10	GPUGCV10	GPUXLC2RT
GPUAC13	GPUMP13	GPUCO13	GPUCSC13	GPUXLC3	GPUGC13	GPUGCV13	GPUXLC3RT
GPUAC16	GPUMP16	GPUCO16	GPUCSC16	GPUXLC4	GPUGC16	GPUGCV16	GPUXLC4RT
GPUAC20			GPUCSC20	GPUXLC5	GPUGC20	GPUGCV20	GPUXLC5RT



## Green Pin® Connecting Link Spare Kit GR10

### Grade 10 spare kit for connecting link

- **Material:** alloy steel, grade 10, quenched and tempered
- **Finish:** self-coloured
- **Temperature range:** -40 °C up to +200 °C
- **Certification:** 2.1 3.1 CE IIB

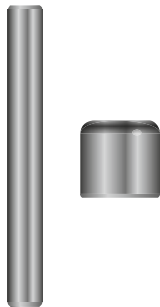

URMJ

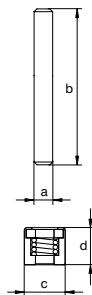

partnumber	diameter pin	length pin	diameter	width	weight each
	a mm	b mm	c mm	d mm	kg
GPURMJ6	5	41	12	10	0.01
GPURMJ8	6	54	13	14	0.02
GPURMJ10	8	66	16	18	0.02
GPURMJ13	10	84	22	22	0.05
GPURMJ16	12	105	25	25	0.10
GPURMJ20	15	122	28	32	0.15

partnumber	for fitting
	UMJ
GPURMJ6	GPUMJ6
GPURMJ8	GPUMJ7
	GPUMJ8
GPURMJ10	GPUMJ10
GPURMJ13	GPUMJ13
GPURMJ16	GPUMJ16
GPURMJ20	GPUMJ20



## Green Pin® Latch GR10

### Forged latch for grade 10

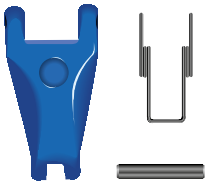

ULF

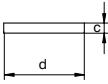
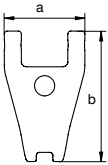

- **Material:** steel
- **Finish:** painted blue
- **Temperature range:** -40 °C up to +200 °C
- **Certification:** 2.1 CE IIB

partnumber	width		length		diameter pin	length pin	weight each
	a mm	b mm	c mm	d mm	c mm	d mm	kg
GPULF0	24	44	4	24			0.03
GPULF1	31	59	5	30			0.07
GPULF2	41	65	5	40			0.11
GPULF3	41	79	6	40			0.18
GPULF4	46	81	6	45			0.20
GPULF5	50	100	8	50			0.40

partnumber	for fitting	
	UCSO	UCSC
GPULF0	GPUCSO6	GPUCSC6
GPULF1	GPUCSO8	GPUCSC7
		GPUCSC8
GPULF2	GPUCSO10	GPUCSC10
GPULF3	GPUCSO13	GPUCSC13
GPULF4	GPUCSO16	GPUCSC16
GPULF5	GPUCSO20	GPUCSC20

# LIFTING SLING FITTINGS FOR GREEN PIN TYCAN® CHAIN



## Applications

Green Pin Tycan® fibre chain offers all the performance and flexibility of steel chain but is eight times lighter than steel. A choice of five sizes of lifting chain with matching fittings allows you to manufacture a complete chain assembly with a Working Load Limit of up to 21.2 t. The soft touch and light weight makes Green Pin Tycan® easy to use, allows quicker application and greatly reduces the potential of damage to cargo, a critical factor when handling objects with sensitive surfaces.

For specific product information the following product groups can be found on the mentioned page:

















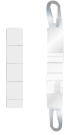





Top links					
					
<b>UMS</b> page 208	<b>UMTS</b> page 209	<b>UMSW</b> page 210	<b>UMTSW</b> page 211		
Connectors					
					
<b>UMJT</b> page 212	<b>UMJ</b> page 213				
Chain					
					
<b>FCHLIFT</b> page 214	<b>SLEEVE</b> page 214				

Table continues on next page

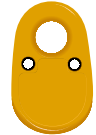
Shorteners					
					
<b>UCRCT</b> page 215					
End-fittings					
					
<b>UCSO</b> page 216	<b>UCSCT</b> page 216	<b>UXLO</b> page 217	<b>UXLORT</b> page 217	<b>UXLE</b> page 218	<b>UXLERT</b> page 218
Accessories					
					
<b>TAG</b> page 219	<b>UTAGF</b> page 219	<b>TAGRFID</b> page 220	<b>CHIPRFID</b> page 220	<b>VR</b> page 221	<b>VRRRT</b> page 221
					
<b>UACT</b> page 222	<b>UALT</b> page 222	<b>URMJ</b> page 223	<b>ULF</b> page 223		

## Range

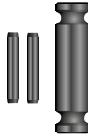
Green Pin® supplies a range of grade 10 Green Pin Tycan® chain fittings, specially developed for use with Green Pin Tycan®, include a connecting link, a shortening hook and a sling hook. The clevis of the hooks and the bearing surface of the connecting link have been specially designed to perfectly fit Green Pin Tycan® chain links. This guarantees safe assembly of the chain and its fittings. Chain fittings for chain sizes 11x15 (2.6 t) up to 15x40 (10.3 t).

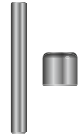
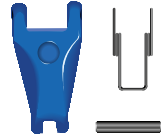
Below Green Pin Tycan® lifting sling fittings can be found:

- Links, e.g. Green Pin® Master Link, Green Pin Tycan® Connecting Link
- Chain, e.g. Green Pin Tycan® Lifting Chain
- Hooks, e.g. Green Pin Tycan® Sling Hook, Green Pin Tycan® Grab Hook

## Design

Green Pin Tycan® Connecting Link and Green Pin Tycan® Sling Hook, Green Pin Tycan® Grab Hook with clevis connection are supplied unassembled and ready for immediate use. Assembly is quick and easy.

Possibility to shorten Green Pin Tycan® fibre chain sling by means Green Pin Tycan® Grab Hook.

Grade 10 lifting sling fittings specially designed for Tycan® fibre chain are marked with:

- manufacturer's symbol - e.g. GP
- size in mm - e.g. 30
- traceability code - e.g. HA
- steel grade - e.g. 10
- item code (specific products) - e.g. UMJT
- origin (specific products) - e.g. France

As prescribed by the Machinery Directive 2006/42/EC our hooks, master links and connecting links are supplied with a CE Declaration of Incorporation (CE IIB), stating the products are in compliance with the requirements of the machinery directive. These products do not have a CE marking, since CE markings are only to be provided for machines, whereas hooks, master links and connecting links are components of machines, and not machines themselves. Providing components with a CE marking is an incorrect interpretation of the Machinery Directive.

Machinery definition according to Machinery Directive 2006/42/EC – Article 2 – definitions (a) and Machinery Regulation 2023/1230/EU:

“An assembly of linked parts or components, at least one of which moves and which are joined together, intended for lifting loads and whose only power source is directly applied human effort.”

“The maximum working load shall be prominently marked on the lifting machinery. The marking shall be legible, indelible and in an un-coded form. Where the maximum working load depends on the configuration of the lifting machinery, each operating position shall be provided with a load plate indicating, preferably in diagrammatic form or by means of tables, the working load permitted for each configuration.”

This definition means that a sling is a Machine and that the hooks, master links and connecting links are not considered as a machine themselves, but as components of a machine. The CE and the WLL markings in consequence, are mandatory only on the assembled sling tag as the sling is the machine according to MD 2006/42/EC. This rule is still valid with the new Machine Regulation 2023/1230 which will replace the MD cited previously within early 2027.

## Finish

All grade 10 Green Pin Tycan® lifting sling fittings are painted. Grade 10 Green Pin Tycan® lifting fittings are painted blue. The same colour as our other Grade 10 lifting sling fittings for steel chain.

## Certification

Specific details of certificate availability can be found on each product page. Please verify your certification requirements with Green Pin® at the time of order.

## Instructions for use

Grade 10 Green Pin Tycan® lifting sling fittings should be inspected before use to ensure that:

- all markings are legible.
- all lifting sling fittings of the complete sling are made of the same steel grade 10.
- a lifting sling fitting with the correct WLL has been selected with respect to the sling design.  
For further details, refer to the EN 818-4 with values for grade 10 and ASME B30.9 standard for Chain Slings.
- the pin, bolt, nut, bush or any other locking system cannot move or vibrate out of position.
- lifting sling fittings are free from nicks, gouges, and cracks.
- lifting sling fittings are not heat treated, modified, repaired, or reshaped by machining or bent.  
(This may affect their Working Load Limit).
- lifting sling fittings items are not distorted or unduly worn. (Maximum allowable wear is 10 % of the original diameter).
- the latch of the hook(s) is present and functional.
- the hook is never side-, tip- or back- loaded.
- the hook is supporting the load correctly.
- the latch should not be supporting any load.
- only use the lifting sling fittings for in-line lifting.

Grade 10 Green Pin Tycan® lifting sling fittings must be regularly inspected in accordance with the safety standards given in the country of use. This is required because the products in use may be affected by issues such as wear, misuse, and overloading, which may lead to deformation and alteration of the material structure. Inspection should take place at least every six months (follow the local rules in the country of use), and more frequently when the links are used in severe operating conditions.

For Green Pin Tycan® Lifting Chain is a specific user manual available, please find the digital user manual on [greenpin.com/faq](https://greenpin.com/faq).

## Testing

Generally load rated products are proof load and MPI tested.

For specific information on certificates, we refer to the separate paragraph on certification.

Grade 10 Green Pin Tycan® lifting sling fittings are proof load tested at the following loads:

for link size	Working Load Limit (WLL)	Proofload* (PL)
mm	t	t
11x15	2.6	6.5
11x20	4	10
15x25	5	12.5
13x30	6.8	17
15x40	10.3	25.75







\* The Green Pin Tycan® chain itself has a proof load of 2 times the WLL

### Temperature

The Green Pin Tycan® lifting fibre chain temperature range is -40 °C up to +70 °C. This chain cannot be used above +70 °C.

## Green Pin Tycan® lifting assembly fittings

Below, you can find an overview of the complete lifting system and complementary products currently on offer, including the article codes for individual components.

		2.6 t WLL (1 leg sling)	4 t WLL (1 leg sling)	5 t WLL (1 leg sling)	6.8 t WLL (1 leg sling)	10.3 t WLL (1 leg sling)
<b>Master links</b>	 UMS UMTS	GPUMS18 (5.4 t) GPUMTS22 (6.5 t)	GPUMS22 (8.2 t) GPUMTS28 (11 t)	GPUMS22 (8.2 t) GPUMTS28 (11 t)	GPUMS25 (11.2 t) GPUMTS36 (17.5 t)	GPUMS30 (16 t) GPUMTS38 (21.2 t)
<b>Connecting links</b>	 UMJT UMJ	GPUMJT15	GPUMJT20	GPUMJ13	GPUMJT30	GPUMJT40
<b>Shorteners</b>	 UCRCT	GPUCRCT15	GPUCRCT20	GPUCRCT25	GPUCRCT30	GPUCRCT40
<b>Chain</b>	 FCHLIFT	FCHLIFT1115	FCHLIFT1120	FCHLIFT1525	FCHLIFT1330	FCHLIFT1540
<b>Sleeve</b>	 SLEEVE	SLEEVE111550	SLEEVE112050	SLEEVE152550	SLEEVE133050	SLEEVE154050
<b>Hooks</b>	 UCSCCT	GPUCSCT15	GPUCSCT20	GPUCSCT25	GPUCSCT30	GPUCSCT40

### Working Load Limit table for Green Pin Tycan® chain slings to EN 818-4 with values for grade 10

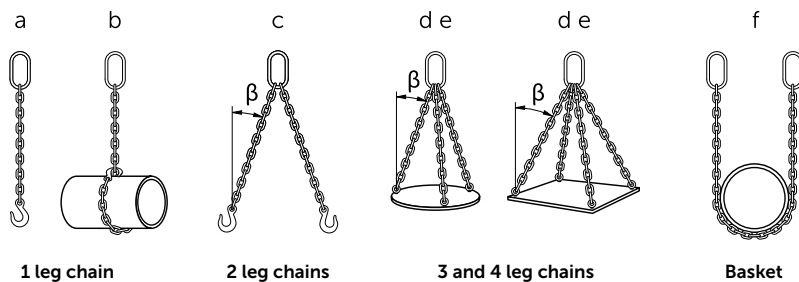

Type of hitch		a	b	c	c	d e	d e	f
Angle of inclination ( $\beta$ )		-*	-	0°-45°	45°-60°	0°-45°	45°-60°	-**
Load factor		1	0.8	1.4	1	2.1	1.5	1.5
Working Load Limit (t)	11x15	2.6	2.08	3.6	2.6	5.46	3.9	3.9
	11x20	4.0	3.2	5.6	4.0	8.4	6.0	6.0
	15x25	5.0	4.0	7.0	5.0	10.5	7.5	7.5
	13x30	6.8	5.44	9.52	6.8	14.28	10.2	10.2
	15x40	10.3	8.2	14.4	10.3	21.2	15.5	15.5

When using multi leg slings make sure that the angles between the lifting points and sling legs are within the range marked on the sling. The angle  $\beta$ , which is the angle between the sling leg and the vertical, shall never exceed 60°.

\* See below capacity reduction table of angles of choke less than 120°

\*\* See below capacity reduction table for non-vertical chain sling legs

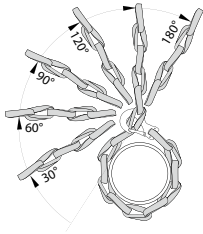

Angle of Choke	Rated load of single leg chain sling	Rated load (t) of single leg chain sling				
		%	11x15	11x20	15x25	13x30
120°-180°	80	2.08	3.20	4.00	5.44	8.24
90°-119°	65	1.69	2.60	3.25	4.42	6.70
60°-89°	55	1.43	2.20	2.75	3.74	5.6
30°-59°	40	1.04	1.60	2.00	2.75	4.12

In a choker configuration you can use two different choker connections:



The hook attached to a link, called anchored basket hitch.



The hook around a link, called traditional choker hitch.

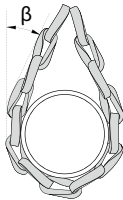

Angle $\beta$	Rated load	Min. dia.	Rated load (t)				
			%	mm	11x15	11x20	15x25
0°-5°	150	120	3.90	6.00	7.50	12.20	15.45
6°-30°	135	120	3.51	5.40	6.75	9.18	13.91
31°-45°	120	120	3.12	4.80	6.00	8.16	12.36
46°-60°	100	120	2.60	4.00	5.00	6.80	10.30

Connect Green Pin Tycan® Lifting Chain to Green Pin Tycan® lifting sling fittings or to certified components with a maximum surface roughness of 5 microns and adhering to below values:

link size	Working Load Limit	minimum pin diameter	minimum clevis width	maximum clevis width
mm	t	mm	mm	mm
11x15	2.6	13	15.5	18
11x20	4	16	20.5	24
15x25	5	16	26	31
13x30	6.8	20	31	37
15x40	10.3	24	41	48

Configuration examples

1 leg chain



2 leg chain



3 and 4 leg chain



Examples of do's and don'ts

Connecting Green Pin Tycan® Lifting Chain directly into hooks (components) where the width/clevis is more than required maximum clevis width is not acceptable. Doing so can cause the layers to spread apart, which in the utmost consequence could have a negative effect on the strength of the chain. The only exception is in a anchored basket hitch.

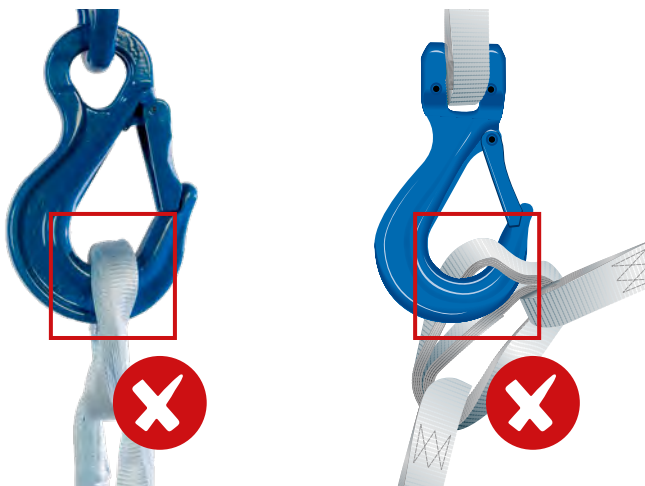

Also make sure that the hook is not hooked in between the layers of the Green Pin Tycan® link.

The unloaded link must never be placed between the loaded link and the body hook.

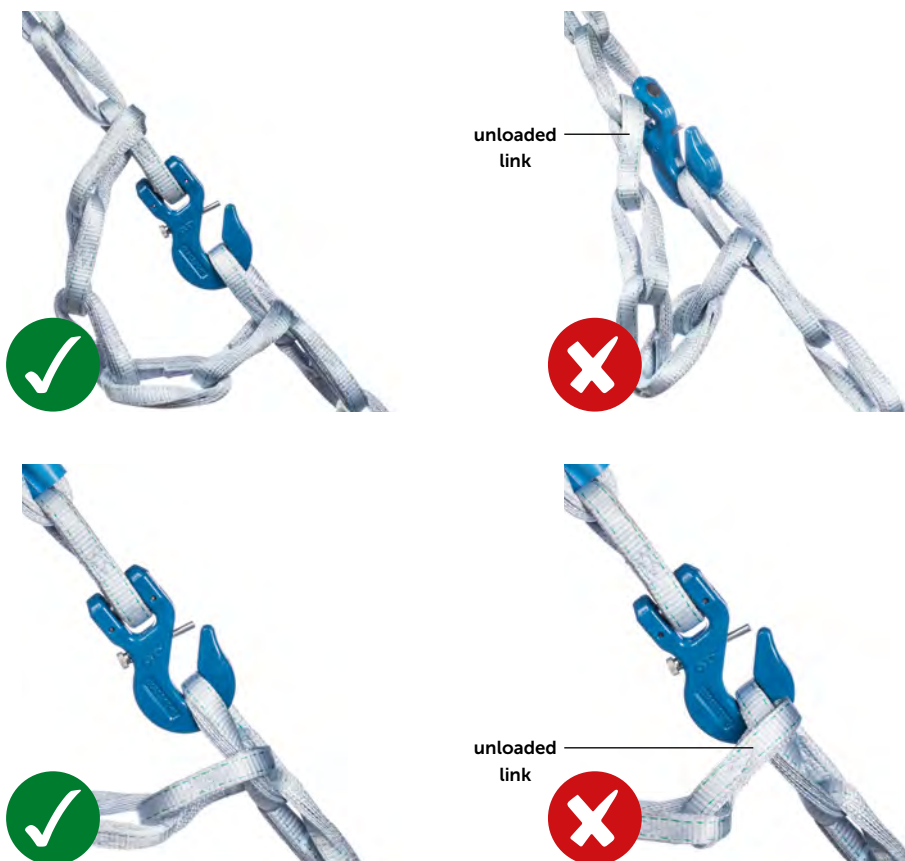



UMS

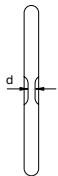
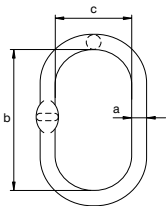

## Green Pin® Master Link GR10

### Grade 10 master link

- **Material:** alloy steel, grade 10, quenched and tempered
- **Safety factor:** MBL equals 4 x WLL
- **Standard:** follows the EN1677 with grade 10 values and conforms to ASTM A952/A952M and ASME B30.9
- **Finish:** painted blue
- **Temperature range:** -40 °C up to +200 °C
- **Certification:** 2.1 2.2 3.1 MTC<sup>®</sup> MPI<sup>®</sup> CE IIB
- **Article code:** scan QR code to see article codes



diameter	chain size Tycan® chain 1 leg	chain size Tycan® chain 2 legs		working load limit	length inside	width inside	thickness	weight each
a mm	mm	$\beta \leq 45^\circ$ mm	$45^\circ < \beta \leq 60^\circ$ mm	t	b mm	c mm	d mm	kg
18	11x15	11x15	11x15	5.4	135	75	9	0.84
22	11x20 / 15x25	11x20 / 15x25	11x20 / 15x25	8.2	170	90	11	1.60
25	13x30	13x30	13x30	11.2	190	103	14	2.17
30	15x40	15x40	15x40	16	235	125	17	4

CAD



# Green Pin® Master Link Assembly GR10

## Grade 10 master link assembly

Scan for additional product details



- **Material:** alloy steel, grade 10, quenched and tempered
- **Safety factor:** MBL equals 4 x WLL
- **Standard:** follows the EN1677 with grade 10 values and conforms to ASTM A952/A952M and ASME B30.9
- **Finish:** painted blue
- **Temperature range:** -40 °C up to +200 °C
- **Certification:** 2.1 2.2 3.1 MTC<sup>b</sup> MPI<sup>a</sup> CE IIB
- **Article code:** scan QR code to see article codes

UMTS

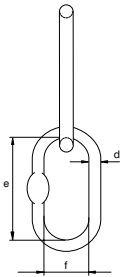
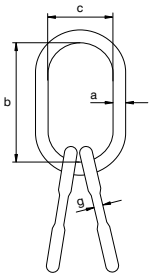

diameter	chain size Tyacan® chain 3/4 legs		working load limit	length inside	width inside	diameter	length inside	width inside	thickness	weight each
	$\beta \leq 45^\circ$ mm	$45^\circ < \beta \leq 60^\circ$ mm								
22	11x15	11x15	6.8	170	90	18	135	75	9	3.30
28	11x20 / 15x25	11x20 / 15x25	11	209	120	20	150	82	11	5.40
36	13x30	13x30	17.7	270	145	25	190	103	14	11.2
38	15x40	15x40	21.2	250	150	30	235	125	17	15.1

CAD



UMSW

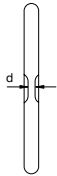
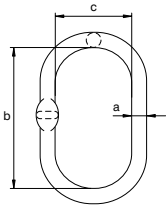

## Green Pin® Wider Master Link GR10

### Grade 10 wider master link

- **Material:** alloy steel, grade 10, quenched and tempered
- **Safety factor:** MBL equals 5 x WLL
- **Standard:** follows the EN1677 with grade 10 values and conforms to ASTM A952/A952M and ASME B30.9
- **Finish:** painted blue
- **Temperature range:** -40 °C up to +200 °C
- **Certification:** 2.1 2.2 3.1 MTC<sup>®</sup> MPI<sup>®</sup> CE IIB
- **Article code:** scan QR code to see article codes

Scan for additional product details



diameter	chain size Tycan® chain 1 leg	chain size Tycan® chain 2 legs		working load limit	length inside	width inside	thickness	weight each
a mm	mm	$\beta \leq 45^\circ$ mm	$45^\circ < \beta \leq 60^\circ$ mm	t	b mm	c mm	d mm	kg
17	11x15	11x15	11x15	4.1	160	90	9	0.85
19	11x20	11x20	11x20	6.7	160	90	9	1.08
25	15x25 / 13x30	15x25 / 13x30	15x25 / 13x30	11.5	210	115	13	2.43
33	15x40	15x40	15x40	17	270	140	17	5.40

CAD



# Green Pin® Wider Master Link Assembly GR10

## Grade 10 wider master link assembly

Scan for additional product details

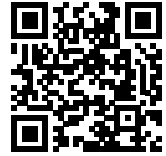

- **Material:** alloy steel, grade 10, quenched and tempered
- **Safety factor:** MBL equals 5 x WLL
- **Standard:** follows the EN1677 with grade 10 values and conforms to ASTM A952/A952M and ASME B30.9
- **Finish:** painted blue
- **Temperature range:** -40 °C up to +200 °C
- **Certification:** 2.1 2.2 3.1 MTC<sup>b</sup> MPI<sup>a</sup> CE IIB
- **Article code:** scan QR code to see article codes

UMTSW

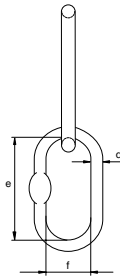
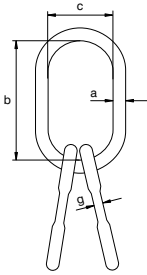

diameter	chain size Tycan® chain 3/4 legs		working load limit	length inside	width inside	diameter	length inside	width inside	thickness	weight each
a mm	$\beta \leq 45^\circ$ mm	$45^\circ < \beta \leq 60^\circ$ mm	t	b mm	c mm	d mm	e mm	f mm	g mm	kg
19	-	11x15	4.3	160	90	14	120	70	9	1.96
23	11x20	11x20	6.7	180	100	17	160	90	9	3.50
40	15x40	15x40	28.1	300	160	33	270	140	17	19.8

CAD



UMJT

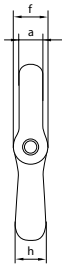
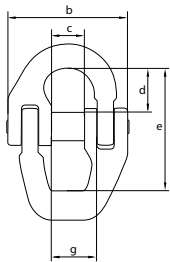

## Green Pin Tycan® Connecting Link GR10

### Grade 10 connecting link

- **Material:** alloy steel, grade 10, quenched and tempered
- **Safety factor:** MBL equals 4 x WLL
- **Standard:** follows the EN1677 with grade 10 values and conforms to ASTM A952/A952M
- **Finish:** painted blue
- **Temperature range:** -40 °C up to +200 °C
- **Certification:** 2.1 2.2 3.1 MTC<sup>®</sup> MPI<sup>®</sup> CE IIB
- **Article code:** scan QR code to see article codes



for chain size	working load limit	diameter	width outside	width inside	length inside	length inside	diameter eye	width inside	diameter	weight each
mm	t	a mm	b mm	c mm	d mm	e mm	f mm	g mm	h mm	kg
11x15	2.6	9	57	14	20	55	16	19	13	0.22
11x20	4	12	66	18	23	67	18	23	16	0.37
13x30	6.8	16	83	21	32	87	24	28	20	0.78
15x40	10.3	19	103	25.5	40	107.5	28	34	24	1.46





# Green Pin® Connecting Link GR10

## Grade 10 connecting link



- **Material:** alloy steel, grade 10, quenched and tempered
- **Safety factor:** MBL equals 4 x WLL
- **Standard:** follows the EN1677 with grade 10 values and conforms to ASTM A952/A952M
- **Finish:** painted blue
- **Temperature range:** -40 °C up to +200 °C
- **Certification:** 2.1 2.2 3.1 MTC<sup>3</sup> MPI<sup>3</sup> DGUV CE IIB
- **Article code:** scan QR code to see article codes

UMJ

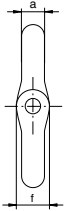
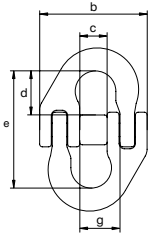

for chain size	working load limit	diameter	width outside	width inside	length inside	length inside	diameter eye	width inside	weight each
mm	t	a mm	b mm	c mm	d mm	e mm	f mm	g mm	kg
15x25	6.8	16	83	21	32	85	24	28	0.68

CAD INFO



FCHLIFT

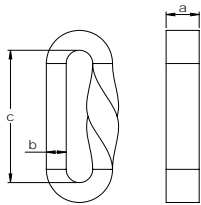

## Green Pin Tycan® Lifting Chain

### Lifting chain made from Dyneema®

- **Material:** made from 100% Dyneema®; layers of webbing in a Mobius twist with stitching on each side
- **Safety factor:** MBL equals 4 x WLL
- **Temperature range:** -40 °C to +70 °C
- **Certification:** 2.1 2.2 MTC<sup>®</sup> DNV TA DNV TQ CE IIA
- **Article code:** scan QR code to see article codes



link size	working load limit	width link	thickness link	length inside	links per meter	elongation at MBL	weight per meter	layers
mm	t	a mm	b mm	c mm		%	kg	
11x15	2.6	15	11	100	10	5	0.32	6
11x20	4	20	11	100	10	5	0.47	6
15x25	5	25	15	100	10	5	0.58	8
13x30	6.8	30	13	125	8	5	0.75	7
15X40	10.3	40	15	175	6	5	1.12	7



SLEEVE

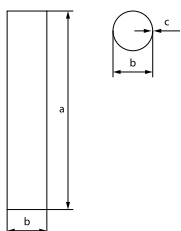

## Green Pin Tycan® Sleeve

### Sleeve made from Dyneema®

- **Material:** 100% Dyneema
- **Certification:** 2.1
- **Article code:** scan QR code to see article codes



for chain size	length	diameter	thickness	weight each
mm	a mm	b mm	c mm	kg
11x15	500	40	1	0.04
11x20	500	50	1	0.05
15x25	500	60	1	0.04
13x30	500	65	1	0.06
15x40	500	75	1	0.10



Scan for additional product details



## Green Pin Tyacan® Grab Hook CL GR10

### Grade 10 clevis grab hook

- **Material:** alloy steel, grade 10, quenched and tempered
- **Safety factor:** MBL equals 4 x WLL and MBL equals 2 x Lashing Capacity
- **Standard:** follows the EN1677 with grade 10 values and conforms to ASTM A952/A952M
- **Finish:** painted blue
- **Temperature range:** -40 °C up to +200 °C
- **Certification:** 2.1 2.2 3.1 MTC<sup>a</sup> MPI<sup>b</sup> CE IIB
- **Article code:** scan QR code to see article codes



UCRCT

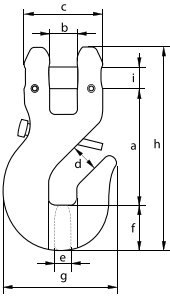

for chain size	working load limit	length	width	width outside	opening	thickness	width	width outside	length outside	diameter pin	weight each
mm	t	a mm	b mm	c mm	d mm	e mm	f mm	g mm	h mm	i mm	kg
11x15	2.6	64	17	44	15	13	23	65	109	13	0.55
11x20	4	81	22	57	20	16	29	85	138	16	1.03
15x25	5	102	24	68	25	16	40	99	178	20	2
13x30	6.8	100	32	74	30	20	40	102	177	20	1.94
15x40	10.3	128	42	96	40	24	44.7	127	216.5	24	3.37

CAD INFO



UCSO

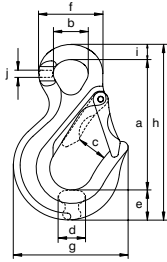

## Green Pin® Sling Hook E GR10

### Grade 10 eye sling hook

- **Material:** alloy steel, grade 10, quenched and tempered
- **Safety factor:** MBL equals 4 x WLL
- **Standard:** follows the EN1677 with grade 10 values and conforms to ASTM A952/A952M
- **Finish:** painted blue
- **Temperature range:** -40 °C up to +200 °C
- **Certification:** 2.1 2.2 3.1 MTC<sup>®</sup> MPI<sup>®</sup> DGVV CE IIB
- **Article code:** scan QR code to see article codes
- **Note:** from 10 t without flat part



for chain size	working load limit	length	diameter inside eye	width opening	thickness	width	diameter eye outside	width outside	length	width	thickness	weight each
mm	t	a mm	b mm	c mm	d mm	e mm	f mm	g mm	h mm	i mm	j mm	kg
11x15	2.6	103	26	30	19	24	51	87	139	12	8	0.52
11x20	4	129	36	33	24	28	65	106	171	15	10	1.09
15x25 / 13x30	6.8	152	41	37	32	39	77	133	209	18	12	1.94
15x40	10.3	191	52	43	40	43	94	165	255	21	17	3.51



UCSCT

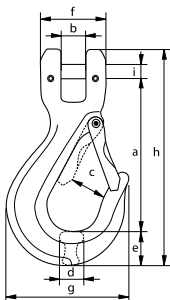

## Green Pin Tycan® Sling Hook CL GR10

### Grade 10 clevis sling hook

- **Material:** alloy steel, grade 10, quenched and tempered
- **Safety factor:** MBL equals 4 x WLL
- **Standard:** follows the EN1677 with grade 10 values and conforms to ASTM A952/A952M
- **Finish:** painted blue
- **Temperature range:** -40 °C up to +200 °C
- **Certification:** 2.1 2.2 3.1 MTC<sup>®</sup> MPI<sup>®</sup> CE IIB
- **Article code:** scan QR code to see article codes



for chain size	working load limit	length	width	width opening	thickness	width	width outside	width outside	length outside	diameter pin	weight each
mm	t	a mm	b mm	c mm	d mm	e mm	f mm	g mm	h mm	i mm	kg
11x15	2.6	112	17	30	20	24	44	87	158	13	0.72
11x20	4	130	22	34	24	28	57	106	186	16	1.31
15x25	5	150	24	37	29	35	68	123	220	20	2.15
13x30	6.8	159	32	37	32	39	74	133	235	20	2.56
15x40	10.3	185	42	45	40	43	96	165	271	24	4.25



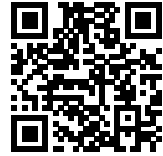

## Green Pin® Self Locking Hook E GR10

### Grade 10 eye self locking hook

- **Material:** alloy steel, grade 10, quenched and tempered
- **Safety factor:** MBL equals 4 x WLL
- **Standard:** follows the EN1677 with grade 10 values and conforms to ASTM A952/A952M
- **Finish:** painted blue
- **Temperature range:** -40 °C up to +200 °C
- **Certification:** 2.1 2.2 3.1 MTC<sup>a</sup> MPI<sup>b</sup> DGUV CE IIB
- **Article code:** scan QR code to see article codes



UXLO

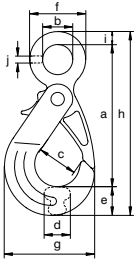

for chain size	working load limit	length	diameter inside eye	width opening	thickness	width	width outside	width outside	length	width	thickness	weight each
mm	t	a	b	c	d	e	f	g	h	i	j	kg
11x15	2.6	136	30	43	24	28	57	91	178	14	8	0.91
11x20	4	168	36	48	32	34	68	110	218	16	10	1.79
15x25 / 13x30	6.8	201	47	63	37	43	87	141	264	20	13	3.36
15x40	10.3	251	60	75	43	56	111	182	332	26	16	7

CAD INFO



## Green Pin® Self Locking Hook E RT GR10

### Grade 10 self locking hook E RT

- **Material:** alloy steel, grade 10, quenched and tempered
- **Safety factor:** MBL equals 4 x WLL
- **Standard:** follows the EN1677 with grade 10 values and conforms to ASTM A952/A952M
- **Finish:** painted blue
- **Temperature range:** -40 °C up to +200 °C
- **Certification:** 2.1 2.2 3.1 MTC<sup>a</sup> MPI<sup>b</sup> DGUV CE IIB
- **Article code:** scan QR code to see article codes



UXLORT

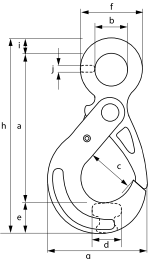

for chain size	working load limit	length	diameter inside eye	width opening	thickness	width	width outside	width outside	length	width	thickness	weight each
mm	t	a	b	c	d	e	f	g	h	i	j	kg
11x15	2.6	136	30	43	24	28	57	91	178	14	7	0.90
11x20	4	168	36	48	32	34	68	111	218	16	10	1.77
15x25 / 13x30	6.8	201	47	63	37	43	87	141	264	20	13	3.34
15x40	10.3	251	60	75	43	56	111	182	332	26	16	6.98

CAD INFO

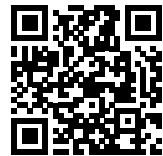



UXLE

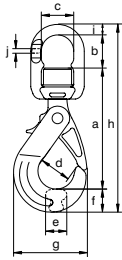

## Green Pin® Self Locking Hook SE GR10

### Grade 10 self locking hook with swivel

- **Material:** alloy steel, grade 10, quenched and tempered
- **Safety factor:** MBL equals 4 x WLL
- **Standard:** follows the EN1677 with grade 10 values and conforms to ASTM A952/A952M
- **Finish:** painted blue
- **Temperature range:** -40 °C up to +200 °C
- **Certification:** 2.1 2.2 3.1 MTC<sup>®</sup> MPI<sup>®</sup> DGVV CE IIB
- **Article code:** scan QR code to see article codes
- **Note:** equipped with thrust needle roller bearings to enable rotation under load



for chain size	working load limit	length	length inside	width inside	width opening	thickness	width	width outside	length	diameter	thickness	weight each
mm	t	a mm	b mm	c mm	d mm	e mm	f mm	g mm	h mm	i mm	j mm	kg
11x15	2.6	149	41	37	43	24	28	91	232	14	8	1.39
11x20	4	186	47	48	48	32	34	112	283	16	11	2.56
15x25 / 13x30	6.8	214	60	58	63	37	44	141	337	21	14	4.56
15x40	10.3	273	67	73	75	43	56	182	420	25	17	9.50



UXLERT

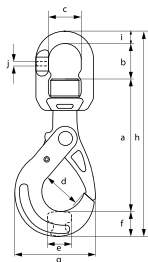

## Green Pin® Self Locking Hook SE RT GR10

### Grade 10 swivel self locking hook with recessed trigger

- **Material:** alloy steel, grade 10, quenched and tempered
- **Safety factor:** MBL equals 4 x WLL
- **Standard:** follows the EN1677 with grade 10 values and conforms to ASTM A952/A952M
- **Finish:** painted blue
- **Temperature range:** -40 °C up to +200 °C
- **Certification:** 2.1 2.2 3.1 MTC<sup>®</sup> MPI<sup>®</sup> DGVV CE IIB
- **Article code:** scan QR code to see article codes
- **Note:** equipped with thrust needle roller bearings to enable rotation under load



for chain size	working load limit	length	length inside	width inside	width opening	thickness	width	width outside	length	diameter	thickness	weight each
mm	t	a mm	b mm	c mm	d mm	e mm	f mm	g mm	h mm	i mm	j mm	kg
11x15	2.6	149	41	37	43	24	28	91	232	14	8	1.38
11x20	4	186	47	48	48	32	34	112	283	16	11	2.54
15x25 / 13x30	6.8	214	60	58	63	37	44	141	337	21	14	4.54
15x40	10.3	273	67	73	75	43	56	182	420	25	17	9.48



Scan for additional product details

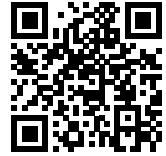

## Green Pin® ID Tag

### Aluminium identification tag

- **Material:** aluminium
- **Finish:** see table below
- **Certification:** 2.1



TAG

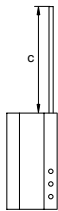
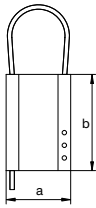

partnumber	finish	width	length	length	weight each
		a mm	b mm	c mm	
TAGVIERGE	self-coloured	51	76	220	0.07
TAGJ	anodized yellow	51	76	220	0.07
TAGGREEN	anodized green	51	76	220	0.07
TAGRED	anodized red	51	76	220	0.07
TAGBLUE	anodized blue	51	76	220	0.07
TAGDEMI	self-coloured	51	38	220	0.04
TAGB without wire rope	self-coloured	51	76		0.06



TAGVIERGE



TAGJ



TAGGREEN



TAGRED



TAGBLUE



TAGDEMI



## Green Pin® ID Tag for Grade 10 Slings

### Forged identification tag for grade 10 slings

- **Material:** drop forged mild steel
- **Finish:** electro galvanized
- **Certification:** 2.1



UTAGF

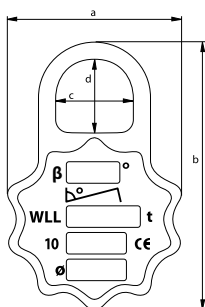

width	length	width inside	length inside	weight each
a mm	b mm	c mm	d mm	kg
79	121	35	32	0.30

RFID

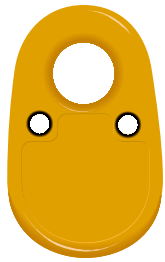

TAGRFID

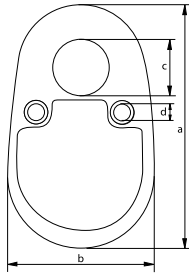

## Green Pin® RFID Tag

### Accessory for radio-frequency identification of slings

- **Material:** stainless steel
- **Standard:** RF Protocol ISO 15693 Operating Frequency HF - 13.56 MHz with individual serial number
- **Finish:** polymer
- **Temperature range:** -40 °C up to +125 °C
- **Certification:** 2.1
- **Note:** IP68; water and ice proof

Scan for additional product details



length	width	diameter	diameter	weight per 100 pcs
a mm	b mm	c mm	d mm	kg
53	33	12	4	1.80

RFID INFO



CHIPRFID

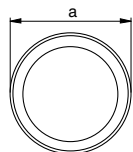

## Green Pin® RFID Chip

### Accessory for radio-frequency identification of slings

- **Material:** polymer
- **Standard:** RF Protocol ISO 15693 Operating Frequency HF - 13.56 MHz with individual serial number
- **Temperature range:** -40 °C up to +125 °C
- **Certification:** 2.1
- **Note:** IP68; water and ice proof

diameter	thickness	weight per 100 pcs
a mm	b mm	kg
6	2	0.02

RFID INFO



## Green Pin® Self Locking Hooks GR8/GR10 Spare Kit

Replacement kit for grade 8 and 10 self locking hooks

- **Material:** steel
- **Finish:** self-coloured
- **Temperature range:** -40 °C up to +200 °C
- **Certification:** 2.1 CE IIB
- **Note:** plastic tube included, to make assembly easier



VR

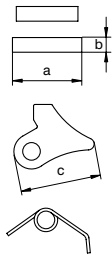

partnumber	length pin	diameter pin	width	weight each
	a mm	b mm	c mm	kg
VR1	22	6	28	0.02
VR2	26	6	31	0.03
VR3	32	8	37	0.05
VR4	40	10	47	0.10
VR5	55	10	58	0.20

partnumber	for fitting		
	UXLO	UXLC	UXLE
VR1	GPUXLO0	GPUXLC0	GPUXLE0
VR2	GPUXLO1	GPUXLC07	GPUXLE1
		GPUXLC1	
VR3	GPUXLO2	GPUXLC2	GPUXLE2
VR4	GPUXLO3	GPUXLC3	GPUXLE3
VR5	GPUXLO4	GPUXLC4	GPUXLE4
	GPUXLO5	GPUXLC5	GPUXLE5

INFO



## Green Pin® Self Locking Hooks RT GR10 Spare Kit

Replacement kit for grade 8 and 10 self locking hooks with recessed trigger

- **Material:** steel
- **Finish:** self-coloured
- **Temperature range:** -40 °C up to +200 °C
- **Certification:** 2.1 CE IIB
- **Note:** plastic tube included, to make assembly easier



VRRT



partnumber	length pin	diameter pin	width	weight each
	a mm	b mm	c mm	kg
GPVR2RT	26	6	31	0.03
GPVR3RT	32	8	37	0.05
GPVR4RT	40	10	47	0.10
GPVR5RT	55	10	58	0.20

partnumber	for fitting		
	UXLORT	UXLCRT	UXLERT
GPVR2RT	GPUXLO1RT	GPUXLC1RT	GPUXLE1RT
GPVR3RT	GPUXLO2RT	GPUXLC2RT	GPUXLE2RT
GPVR4RT	GPUXLO3RT	GPUXLC3RT	GPUXLE3RT
GPVR5RT	GPUXLO4RT	GPUXLC4RT	GPUXLE4RT
	GPUXLO5RT	GPUXLC5RT	GPUXLE5RT

INFO

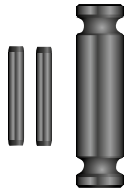

UACT

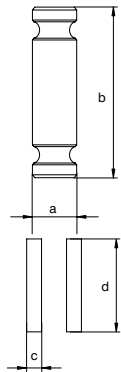

## Green Pin Tycan® Clevis Fittings GR10 Spare Kit

### Grade 10 spare kit for clevis fittings

- **Material:** alloy steel, grade 10, quenched and tempered
- **Finish:** self-coloured
- **Temperature range:** -40 °C up to +200 °C
- **Certification:** 2.1 3.1 CE IIB

partnumber	diameter pin	length pin	diameter pin	length pin	weight each
	a mm	b mm	c mm	d mm	kg
GPUACT15	4	24	13	43	0.04
GPUACT20	4	24	16	56	0.08
GPUACT25	5	35	20	66	0.16
GPUACT30	5	35	20	72	0.16
GPUACT40	6	45	24	94	0.16

partnumber	for fitting	
	UCSCT	UCRCT
GPUACT15	GPUCSCT15	GPUCRCT15
GPUACT20	GPUCSCT20	GPUCRCT20
GPUACT25		GPUCRCT25
GPUACT30	GPUCSCT30	GPUCRCT30
GPUACT40	GPUCSCT40	GPUCRCT40



## Green Pin Tycan® Grab Hook CL GR10 Locking Pin

### Grade 10 locking pin for Green Pin Tycan® clevis grab hook

- **Material:** alloy steel, grade 10
- **Finish:** self-coloured
- **Certification:** 2.1 CE IIB



UALT

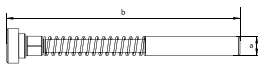

partnumber	diameter pin	length pin	weight each
	a mm	b mm	kg
GPUALT15	5.8	52	0.01
GPUALT20	5.8	63	0.02
GPUALT25	7.8	72	0.03
GPUALT30	7.8	77	0.03
GPUALT40	7.8	95	0.03

partnumber	for fitting
	UCRCT
GPUALT15	GPUCRCT15
GPUALT20	GPUCRCT20
GPUALT25	GPUCRCT25
GPUALT30	GPUCRCT30
GPUALT40	GPUCRCT40



## Green Pin® Connecting Link Spare Kit GR10

### Grade 10 spare kit for connecting link

- **Material:** alloy steel, grade 10, quenched and tempered
- **Finish:** self-coloured
- **Temperature range:** -40 °C up to +200 °C
- **Certification:** 2.1 3.1 CE IIB

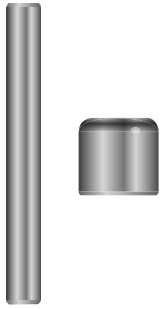

URMJ

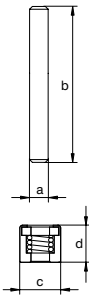

partnumber	diameter pin	length pin	diameter	width	weight each
	a mm	b mm	c mm	d mm	kg
GPURMJ8	6	54	13	14	0.02
GPURMJ10	8	66	16	18	0.02
GPURMJ13	10	84	22	22	0.05
GPURMJ16	12	105	25	25	0.10

partnumber	for fitting	
	UMJ	UMJT
GPURMJ8		GPUMJT15
GPURMJ10		GPUMJT20
GPURMJ13	GPUMJ13	GPUMJT30
GPURMJ16		GPUMJT40



## Green Pin® Latch GR10

### Forged latch for grade 10

- **Material:** steel
- **Finish:** painted blue
- **Temperature range:** -40 °C up to +200 °C
- **Certification:** 2.1 CE IIB

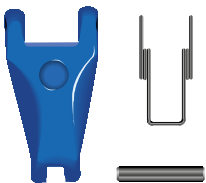

ULF

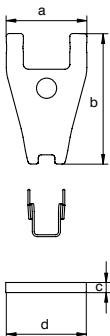

partnumber	width	length	diameter pin	length pin	weight each
	a mm	b mm	c mm	d mm	kg
GPULF1	31	59	5	30	0.07
GPULF2	41	65	5	40	0.11
GPULF3	41	79	6	40	0.18
GPULF4	46	81	6	45	0.20

partnumber	for fitting	
	UCSO	UCSCT
GPULF1	GPUCSO8	GPUCSCT15
GPULF2	GPUCSO10	GPUCSCT20 - GPUCSCT25
GPULF3	GPUCSO13	GPUCSCT30
GPULF4	GPUCSO16	GPUCSCT40

# LIFTING SLING FITTINGS FOR SYNTHETIC SLINGS



## Applications

Green Pin® grade 8 lifting sling fittings for synthetic slings enable the connection with web slings.

For specific product information the following product groups can be found on the mentioned page:





















Top links					
					
<b>MS</b> page 228	<b>MTS</b> page 229				
Connectors					
					
<b>COS</b> page 230	<b>MJS</b> page 231				
End-fittings					
					
<b>XLS</b> page 231					

Table continues on next page

Sling accessories					
					
<b>E-6110</b> page 232	<b>G-6120</b> page 232	<b>G-6128</b> page 233	<b>E-6131/G-6131</b> page 234	<b>S-6134</b> page 235	<b>E-6135/G-6135</b> page 236
					
<b>G-6170</b> page 237	<b>G-6142</b> page 238	<b>G-6151</b> page 239	<b>P-6190</b> page 240	<b>P-6195</b> page 240	
Accessories					
					
<b>TAG</b> page 241	<b>TAGRFID</b> page 242	<b>CHIPRFID</b> page 242	<b>RCOS</b> page 243	<b>RMJ</b> page 243	

## Range

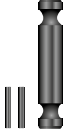
Green Pin® supplies a range of grade 8 lifting sling fittings for synthetic slings for different sizes. The lifting sling fittings are suitable for web slings made according to European standard. See specific lifting sling fitting to know which size fits the web sling.

## Design

The Green Pin® lifting sling fittings for synthetic are the ideal fittings for lifting with synthetic round- and/or flat web slings. The optimal bearing surface of body/pin means load on the web sling is distributed equally. Wear of the web sling is also minimized as a result of the smooth finish of the lifting sling fittings result, damage to the web sling is minimized and its lifespan extended.

Grade 8 lifting sling fittings for synthetic are generally marked with:

- manufacturer's symbol - e.g. GP
- size in mm and/ or inch - e.g. 13 and/or 1/2"
- traceability code - e.g. HA
- steel grade - e.g. 8
- item code (specific products) - e.g. MJS
- origin (specific products) - e.g. France

As prescribed by the Machinery Directive 2006/42/EC our hooks, master links and connecting links are supplied with a CE Declaration of Incorporation (CE IIB), stating the products are in compliance with the requirements of the machinery directive. These products do not have a CE marking, since CE markings are only to be provided for machines, whereas hooks, master links and connecting links are components of machines, and not machines themselves. Providing components with a CE marking is an incorrect interpretation of the Machinery Directive.

Machinery definition according to Machinery Directive 2006/42/EC – Article 2 – definitions (a) and Machinery Regulation 2023/1230/EU:

"An assembly of linked parts or components, at least one of which moves and which are joined together, intended for lifting loads and whose only power source is directly applied human effort."

"The maximum working load shall be prominently marked on the lifting machinery. The marking shall be legible, indelible and in an un-coded form. Where the maximum working load depends on the configuration of the lifting machinery, each operating position shall be provided with a load plate indicating, preferably in diagrammatic form or by means of tables, the working load permitted for each configuration."

This definition means that a sling is a Machine and that the hooks, master links and connecting links are not considered as a machine themselves, but as components of a machine. The CE and the WLL markings in consequence, are mandatory only on the assembled sling tag as the sling is the machine according to MD 2006/42/EC. This rule is still valid with the new Machine Regulation 2023/1230 which will replace the MD cited previously within early 2027.

## Finish

All grade 8 lifting sling fittings for synthetic are painted. Grade 8 lifting sling fittings for synthetic under the Green Pin® brand will be painted white.

Some products are mentioned as painted white\*, but could be for some sizes delivered with a yellow or red finish.

## Certification

Specific details of certificate availability can be found on each product page. Please verify your certification requirements with Green Pin® at the time of order.

## Instructions for use

Grade 8 lifting sling fittings for synthetic, should be inspected before use to ensure that:

- all markings are legible.
- all lifting sling fittings of the complete sling are made of the same steel grade 8.
- a lifting sling fitting with the correct WLL has been selected with respect to the sling design. For further details, refer to the EN 818-4.
- the pin, bolt, nut, bush or any other locking system cannot move or vibrate out of position.
- lifting sling fittings are free from nicks, gouges, and cracks.
- lifting sling fittings are not heat treated, modified, repaired, or reshaped by machining or bent. (This may affect their Working Load Limit).
- lifting sling fittings items are not distorted or unduly worn. (Maximum allowable wear is 10 % of the original diameter)
- the latch of the hook(s) is present and functional.
- the hook is never side-, tip- or back- loaded.
- the hook is supporting the load correctly.
- the latch should not be supporting any load.
- only use the lifting sling fittings for in-line lifting.

Green Pin® grade 8 lifting sling fittings for synthetic must be regularly inspected in accordance with the safety standards given in the country of use. This is required because the products in use may be affected by issues such as wear, misuse, and overloading, which may lead to deformation and alteration of the material structure. Inspection should take place at least every six months (follow the local rules in the country of use), and more frequently when the links are used in severe operating conditions.

## Testing

Generally load rated products are proof load and MPI tested.

For specific information on certificates we refer to the separate paragraph on certification.

The Green Pin® lifting sling fittings for synthetic are proof load tested at the following loads:

Working Load Limit (WLL)	Proofload (PL)
t	t
2	5
3.2	8
5.4	13.5
8.2	20.5



MS

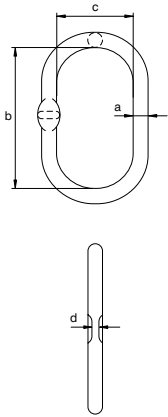

## Green Pin® Master Link EN 1677-4 GR8

### Grade 8 master link EN 1677-4

- **Material:** alloy steel, grade 8, quenched and tempered
- **Safety factor:** MBL equals 4 x WLL
- **Standard:** EN 1677-4, ASTM A952/952M and ASME B30.9
- **Finish:** painted white\*
- **Temperature range:** -40 °C up to +200 °C
- **Certification:** 2.1 2.2 3.1 MTC<sup>®</sup> MPI<sup>®</sup> CE IIB
- **Article code:** scan QR code to see article codes
- **Note:** from 50 t without flat part

Scan for additional product details



diameter	diameter chain 1 leg	diameter chain 2 legs		working load limit	length inside	width inside	thickness	weight each
a mm	mm	$\beta \leq 45^\circ$ mm	$45^\circ < \beta \leq 60^\circ$ mm	t	b mm	c mm	d mm	kg
13	6/7	6	6/7	1.6	115	60	7	0.40
16	8	7/8	8	3.2	120	70	7	0.60
18	10	10	10	4.5	135	75	9	0.84
20	13	-	13	6.2	150	82	11	1.10
22	16	13	16	8.2	170	90	14	1.60
25	18	-	18	10.6	190	103	14	2.30
28	20	16	19	12.8	209	120	17	3.10
30	20/22	18	20/22	15.5	235	125	17	4
36	-	19/20	-	20	270	145	22	6.60
38	26	22	26	25	250	150	22	7.10
45	32	26	32	37	300	200	22	12.1
50	-	32	-	50	380	200	-	18
55	-	-	-	63	360	200	-	21
70	-	-	-	100	500	250	-	44
80	-	-	-	125	503	280	-	60.7

CAD INFO

\* could be delivered with a yellow or red finish



# Green Pin® Master Link Assembly EN 1677-4 GR8

## Grade 8 master link assembly EN 1677-4

Scan for additional product details

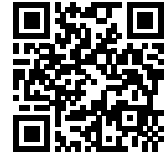

MTS

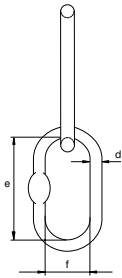
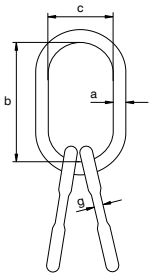

- **Material:** alloy steel, grade 8, quenched and tempered
- **Safety factor:** MBL equals 4 x WLL
- **Standard:** EN 1677-4, ASTM A952/952M and ASME B30.9
- **Finish:** painted white\*
- **Temperature range:** -40 °C up to +200 °C
- **Certification:** 2.1 2.2 3.1 MTC<sup>b</sup> MPI<sup>a</sup> CE IIB
- **Article code:** scan QR code to see article codes
- **Note:** from 60 t without flat part

diameter	diameter chain 3/4 legs		working load limit	length inside	width inside	diameter	length inside	width inside	thickness	weight each
a mm	$\beta \leq 45^\circ$ mm	$45^\circ < \beta \leq 60^\circ$ mm	t	b mm	c mm	d mm	e mm	f mm	g mm	kg
16	6	6/7	2.5	120	70	13	115	60	7	1.20
18	6/7	8	3.5	135	75	16	120	70	7	3.10
22	8	10	6.5	170	90	18	135	75	9	3.30
25	10	13	8.5	190	103	20	150	82	11	4.50
28	-	-	10	209	120	20	150	82	11	5.40
30	13	16	13	235	125	22	170	90	14	7.20
36	16	18/19	17	270	145	25	190	103	14	11.2
38	-	20	20.8	250	150	28	209	120	17	13.3
45	18/20	22	30	300	200	36	270	145	22	25.3
50	22	26	40	380	200	38	250	150	22	32.2
55	26	32	50	360	200	38	250	150	22	35.2
60	-	-	60	430	220	45	300	200	45	54.2
70	32	-	80	500	250	55	360	200	55	86
80	-	-	100	503	250	55	360	200	55	103

CAD INFO

\* could be delivered with a yellow or red finish



# Green Pin® Round Web Sling Connector GR8

## Grade 8 round web sling connector



- **Material:** alloy steel, grade 8, quenched and tempered
- **Safety factor:** MBL equals 4 x WLL
- **Standard:** EN1677-1 and ASTM A952/952M
- **Finish:** painted white\*
- **Temperature range:** -40 °C up to +200 °C
- **Certification:** 2.1 2.2 3.1 MTC<sup>a</sup> MPI<sup>b</sup> CE IIB
- **Article code:** scan QR code to see article codes

COS

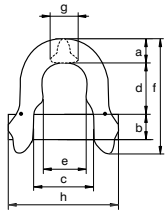

working load limit	width	diameter pin	width	length inside	width inside	length outside	thickness	width outside	weight each
t	a mm	b mm	c mm	d mm	e mm	f mm	g mm	h mm	kg
2	14	9	33	35	23	66	15	59	0.18
3.2	18	13	44	45	30	86	20	75	0.37
5.4	22	16	57	59	38	107	25	94	0.72
8.2	28	20	70	72	48	133	31	117	1.35

### Example combinations with COS:



MS + CO + COS



COS + XLC



COS + CSC

\* could be delivered with a yellow or red finish



## Green Pin® Round Web Sling Connecting Link GR8

### Grade 8 round web sling connecting link

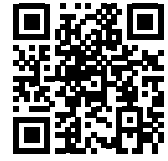

MJS

- **Material:** alloy steel, grade 8, quenched and tempered
- **Safety factor:** MBL equals 4 x WLL
- **Standard:** EN1677-1 and ASTM A952/952M
- **Finish:** painted white\*
- **Temperature range:** -40 °C up to +200 °C
- **Certification:** 2.1 2.2 3.1 MTC<sup>a</sup> MPI<sup>b</sup> CE IIB
- **Article code:** scan QR code to see article codes

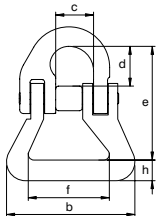

for chain diameter	working load limit	diameter	width outside	width inside	length inside	length	width inside	diameter eye	thickness	weight each
mm	t	a mm	b mm	c mm	d mm	e mm	f mm	g mm	h mm	kg
7/8	2	9	66	19	21	60	41	13	14	0.31
10	3.2	10	75	23	24	75	46	18	15	0.51
13	5.4	14	87	28	32	90	52	24	19	1.01

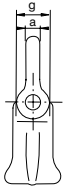

## Green Pin® Flat Web Sling Safety Hook GR8

### Grade 8 flat web sling self locking hook

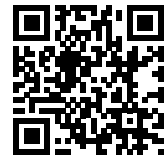

XLS

- **Material:** alloy steel, grade 8, quenched and tempered
- **Safety factor:** MBL equals 4 x WLL
- **Standard:** EN1677-1
- **Finish:** painted white
- **Temperature range:** -40 °C up to +200 °C
- **Certification:** 2.1 2.2 3.1 MTC<sup>a</sup> MPI<sup>b</sup> CE IIB
- **Article code:** scan QR code to see article codes

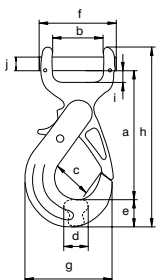

working load limit	length	width	width opening	thickness	width	width outside	width outside	length outside	length inside	diameter pin	weight each
t	a mm	b mm	c mm	d mm	e mm	f mm	g mm	h mm	i mm	j mm	kg
2	161	62	47	32	35	94	111	222	18	16	2.11

\* could be delivered with a yellow or red finish



E-6110

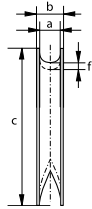
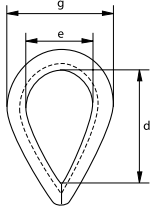

## Thimbles

### Standard commercial

- **Material:** mild steel
- **Finish:** electro-galvanized
- **Certification:** 2.1 CE IIB

diameter rope	width groove	width overall	length	length inside	width inside	thickness back	width	weight per 100 pcs
mm	a mm	b mm	c mm	d mm	e mm	f mm	g mm	kg
4	4	7	25	16	11	2.5	19	0.50
5	5	8	31	22	16	3	25	0.80
6	6	10	37	26	19	3.5	30	1.40
8	8	12	51	34	24	5	38	2.80
9	9	13	57	38	29	5.5	44	3
10	10	16	64	42	32	5.5	49	4.80
12	12	18	76	51	38	6.5	57	8
14	14	20	82	57	40	8	62	10
16	16	22	89	60	42	9	66	15
18	18	26	102	67	45	10	73	22
20	20	28	115	76	51	11	81	25
22	22	30	127	83	54	12.5	87	32
24	24	32	138	90	64	14	100	46
26	26	36	152	102	68	14.5	107	66
28	28	38	165	110	73	16	115	77
30	30	42	178	120	79	17	125	80
32	32	44	203	143	93	18	141	130



G-6120

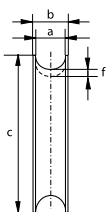
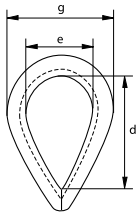

## Thimbles

### Heavy duty stub-end

- **Material:** mild steel
- **Finish:** hot dipped galvanized
- **Certification:** 2.1 CE IIB

diameter rope	width groove	width overall	length	length inside	width inside	thickness back	width	weight per 100 pcs
mm	a mm	b mm	c mm	d mm	e mm	f mm	g mm	kg
8	9	13	51	35	22	4	44	0.50
10	11	15	64	47	30	4	54	0.80
12	13	18	76	57	35	5	62	1.40
14	15	21	89	65	45	6	76	2.80
16	18	22	102	75	50	6	83	3
18	20	28	114	85	53	7	91	4.80
20	22	30	127	94	60	8	102	8
22	24	31	140	107	65	9	110	10
24	26	34	152	114	70	9.5	118	15
28	30	39	178	130	80	10	134	22
32	34	41	203	157	100	10	162	25
36	38	48	229	175	115	11	182	32
40	42	51	254	198	120	12	188	46
44	46	62	280	214	130	14	210	66
50	53	65	305	220	140	18	248	77
56	57	68	356	245	150	23	262	80
64	67	85	407	286	185	20	280	130

# C

## Thimbles

### Heavy duty stub-end reinforced with welded fillet plate



G-6128

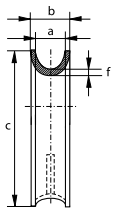
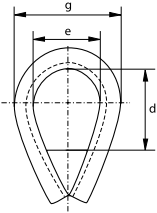

- **Material:** mild steel
- **Finish:** hot dipped galvanized reinforced with a welded fillet plate
- **Certification:** 2.1 CE II B

width groove	width overall	length	length inside	width inside	thickness back	width	weight per piece
a mm	b mm	c mm	d mm	e mm	f mm	g mm	kg
35	55	220	100	80	10	150	3.20
40	65	245	120	90	12	160	5.10
50	80	290	125	110	16	200	9.20
62	100	360	160	140	20	250	17.4
72	115	390	175	160	20	265	19.4
85	125	470	245	190	20	300	29
100	150	540	290	200	25	370	39
115	165	570	300	210	25	380	52

For shackle

group	width groove								
	a mm								
	35	40	50	62	72	85	100	115	
G-4161	17, 25	25	35, 42.5	55	85				
G-4163	17, 25	25	35, 42.5	55	85				
G-4151	17, 25	25	35, 42.5	55	85				
G-4153	17, 25	25	35, 42.5	55	85				
P-6036						120, 150	150, 200		
G-6038						120, 150	150, 200		
P-6033	30	30	40, 55	75	125	125			
G-5263	30, 40	40		85	120	150, 175	175		
G-5163	17, 25	25	35, 42.5	55	85				
P-6031						120, 150	150, 200		
G-4263	4.75 ~ 25	6.5 ~ 25	9.5 ~ 30	16 ~ 55	25 ~ 75	30 ~ 75	55, 75	75	
P-5363	17, 25	25	35, 42.5	55	85				
P-5365	17, 25	25	35, 42.5	55	85	120, 150	150, 200		
P-5367	17, 25	25	35, 42.5	55	85	120, 150	150		
G-4164	17, 25	25							
G-4154	17, 25	25							
G-4169	17								
G-4159	17								

C



E-6131  
G-6131

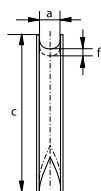
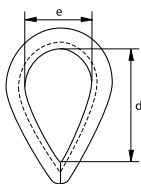

## Thimbles

Generally to DIN 6899 (B)

- **Material:** mild steel
- **Standard:** generally to DIN 6899 (B)
- **Finish:** thimbles for rope diameters up to and including 6 mm are electro-galvanized, other diameters are hot dipped galvanized
- **Certification:** 2.1 CE IIB

diameter rope	width groove	length	length inside	width inside	thickness back	weight per 100 pcs
mm	a mm	c mm	d mm	e mm	f mm	kg
2.5	3	22	19	12	1.6	0.60
3.5	4	26	21	13	1.6	0.80
4	5	32	23	14	1.9	1
5	6	38	25	16	2.4	2
6	7	44	28	18	2.4	2
7	8	51	32	20	2.8	2.70
9	10	57	38	24	3.1	4.10
11	12	64	45	28	3.3	6.90
13	13	70	48	30	3.3	7.20
13	14	76	51	32	3.7	10.2
15	16	83	58	36	3.8	16.4
16	17	89	61	38	4.7	19
17	18	95	64	40	4.7	20.3
18	20	102	72	45	5.7	27.3
20	22	114	80	50	5.7	30.8
22	24	127	90	56	6.5	44.8
24	26	140	99	62	6.8	59.2
26	28	152	112	70	8	72
28	30	165	120	75	8	104
30	32	178	128	80	8	115
32	34	203	152	95	8.5	153
34	36	216	160	100	8.5	176
36	38	229	176	110	8.5	176
38	40	241	184	115	10.5	292
40	42	254	192	120	10.5	320
42	45	305	240	150	10.5	364

C



S-6134

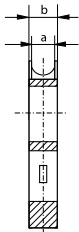
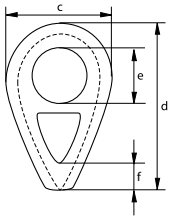

# Thimbles

According to DIN 3091

- **Material:** cast mild steel, (GTW 40)
- **Standard:** according to DIN 3091
- **Finish:** self-coloured
- **Certification:** 2.1 CE II B
- **Note:** the diameter (e) of the thimble for diameter wire rope 72 mm is 140 mm

diameter rope	width groove	width overall	width	length	diameter	length	weight per 100 pcs
mm	a mm	b mm	c mm	d mm	e mm	f mm	kg
8	9	15	40	56	14	-	18
10	11	17.5	50	70	18	-	32
12	13	20	60	84	21	-	52
14	16	23.5	70	98	25	-	80
16	18	26	80	130	28	16	90
18	20	28.5	90	145	31	18	121
20	22	31	100	161	35	20	161
22	24	33.5	110	177	38	22	211
24	26	36	120	193	41	24	271
26	29	39.5	130	209	44	26	355
28	31	42	140	224	47	28	420
32	35	47	160	256	53	32	630
36	40	53	180	288	59	36	884
40	44	58	200	320	65	40	1100
44	48	63	220	352	70	44	1500
48	53	69	240	384	76	48	2000
52	57	74	260	416	81	52	2500
56	62	80	280	448	86	56	3200
64	70	90	320	512	95	64	4600
72	79	101	360	576	140	72	6600



E-6135  
G-6135

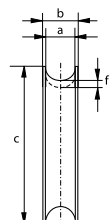
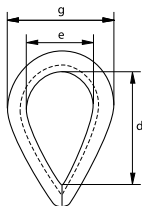

## Thimbles

Generally to DIN 3090

- **Material:** mild steel
- **Standard:** generally to DIN 3090
- **Finish:** for diameter 4 and 6 mm electro-galvanized  
other diameters hot dipped galvanized
- **Certification:** 2.1 CE II B

diameter wire rope	width groove	width overall	length	length inside	width inside	thickness back	width	weight per 100 pcs
mm	a mm	b mm	c mm	d mm	e mm	f mm	g mm	kg
4	5	8	35	20	10	2.1	25	1.40
6	7	10	50	30	15	2.6	33	3
8	9	13	68	40	20	4	43	7.10
10	11	15	77	50	25	5	47	17
12	13	19	100	60	30	6	63	24
14	16	22	110	70	35	8	70	31
16	18	25	125	80	40	8	80	50
18	20	27	142	90	45	9	90	62
20	22	30	155	100	50	10	102	90
22	24	33	165	110	55	10	107	100
24	26	35	180	120	60	10	120	130
26	29	36	190	130	65	12	122	220
28	31	37	197	140	70	12	128	240
32	35	43	225	160	80	15	145	216
36	40	60	250	180	90	15	170	430
40	44	66	290	200	100	20	190	570
44	48	72	315	220	110	20	205	850
48	53	77	350	240	120	20	220	1120
52	57	88	380	260	130	25	235	1530
56	62	95	405	280	140	25	270	2148
60	66	105	430	300	150	25	285	2300
64	70	110	485	320	160	30	310	3500

C

# Thimbles

Generally to EN 13411-1

- **Material:** mild steel
- **Standard:** generally to EN 13411-1 formerly BS 464
- **Finish:** hot dipped galvanized
- **Certification:** 2.1 CE IIB



G-6170

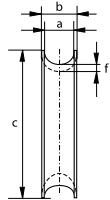
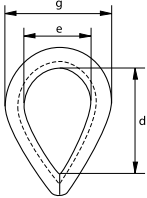

diameter rope		width groove	width overall	length	length inside	width inside	thickness back	width	weight per 100 pcs
inch	mm	a mm	b mm	c mm	d mm	e mm	f mm	g mm	kg
3/16	5	6	9.5	47	27	18	3	32	3.50
1/4	7	7	11	51	33	20.5	3.5	36	2.80
5/16	8	8	12.7	52	33	22	4	38	5.70
3/8	10	10	14.3	64	38	25	6.3	47.6	8
7/16	11	13	17.5	73	41	29	7.9	52	14.2
1/2	13	14	20.6	79	45	32	7.9	58.8	18
9/16	14	15	20.6	88	56	38	7.9	64	18.9
5/8	16	16	22.2	96	59	41	8.7	74.5	22.4
11/16	17	19	28.6	108	67	45	9.5	79.4	39.7
3/4	19	21	28.6	124	73	51	11.1	92	45.6
7/8	22	22	31.7	131	83	56	12.7	102	61.5
15/16	24	25	33.4	146	92	64	12.7	110	106
1	25	27	35	162	108	70	14.3	119	97.3
1 1/8	29	29	38	178	112	76	15.9	133	151
1 1/4	32	33	41.3	197	133	95	15.9	152	204
1 3/8	35	38	47.6	228	152	105	19	175	318
1 1/2	38	41	52	254	165	114	23.8	197	363
1 5/8	41	47	57	280	188	120	24	205	499
1 3/4	44	51	57	286	178	127	25.4	228	556
1 7/8	48	60	66.6	317	190	133	28.6	248	-
2	51	64	69.8	330	203	140	30.1	257	-
2 1/8	54	64	69.8	330	203	140	30.1	257	-
2 1/4	57	67	76.2	356	246	160	31.7	296	-
2 1/2	64	75	93	420	255	170	43	300	-

C



G-6142

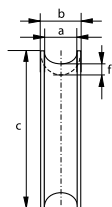
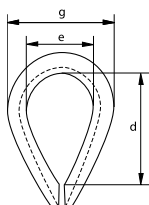

## Thimbles

Generally to US Fed. Spec. FF-T-276b type III

- **Material:** mild steel
- **Standard:** generally to US Federal Specification FF-T-276b type III and generally to EN 13411-1
- **Finish:** hot dipped galvanized
- **Certification:** 2.1 CE II B

diameter rope	width groove	width overall	length	length inside	width inside	thickness back	width	weight per 100 pcs
mm	a mm	b mm	c mm	d mm	e mm	f mm	g mm	kg
6	7	10	56	41	22	1.5	38	2.70
8	8	12.6	64	48	27	2	46	5.10
9	10	17.2	73	54	26	2.5	54	9.10
11	12	18	83	60	32	3	60	13.9
13	13.6	21.4	92	70	38	4	70	19.9
14	15	23	92	70	38	4	68	20.5
16	16.8	24.5	103	83	44	4	78	29.8
19	19.8	31.8	127	95	51	6	97	60.8
22	24	36	140	108	57	6	108	80.4
25	27	39	156	114	63	6	125	109
28 - 32	34	46	178	130	73	6	148	147
32 - 35	36	56	228	165	89	10	173	366
35 - 38	39	63	228	158	89	12	181	478
41	42	66	285	203	101	12	206	731
45	45	69	309	228	114	12	216	778
48 - 51	54	78	380	305	152	12	250	1150
57	60	92	435	356	178	16	301	1935
64	70	110	465	360	178	20	310	2640
76	85	125	550	410	180	20	330	3850

C

# Thimbles

## Pennant line type

- **Material:** mild steel
- **Finish:** hot dipped galvanized produced with a welded fillet plate
- **Certification:** 2.1 CE II B



G-6151

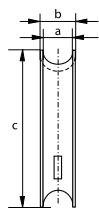
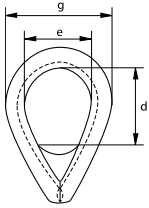

diameter wire rope	width groove	width overall	length	length inside	width inside	width	weight each
mm	a mm	b mm	c mm	d mm	e mm	g mm	kg
16	17	22	102	50	50	75	0.40
18	19	25	114	50	53	85	0.50
20	21	29	127	60	60	100	0.80
22	23	33	140	60	65	110	0.90
24	25	34	152	70	70	115	1
28	30	38	178	75	80	135	1.70
30	33	44	203	80	100	155	2.50
36	38	49	229	110	115	175	4
40	41	52	254	120	120	190	4.50
44	46	60	279	120	130	210	7
50	52	65	305	140	145	245	8.30
56	60	72	356	155	155	260	12.5
64	70	84	432	200	190	310	19.5
76	81	119	483	235	230	350	29
82	92	130	559	240	255	395	35
90	105	145	610	275	280	430	42
120	120	155	660	295	285	450	58

C



P-6190

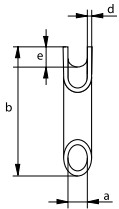

## Thimbles

### Tubular type

- Material: mild steel
- Finish: painted
- Certification: 2.1 CE IIB

diameter wire rope	diameter	length	width inside	thickness	height	weight each
mm	a mm	b mm	c mm	d mm	e mm	kg
10	12	90	23	4	8	0.23
12	15	105	27	5	10	0.40
14	17	115	27	5	10	0.50
16	19	120	32	5	12	0.60
18	22	140	35	5	15	0.75
22	25	180	45	6	16	1.40
24	28	180	45	7	16	1.75
26	30	195	47	7	18	2
32	35	215	60	7	22	2.50
38	45	260	70	7	27	3.50
44	50	280	75	7	28	4.20

C



P-6195

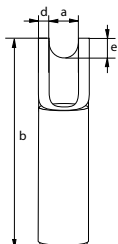
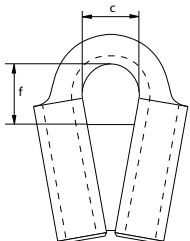

## Thimbles

### Tubular type with welded plate

- Material: mild steel
- Finish: painted
- Certification: 2.1 CE IIB

diameter wire rope	width groove	length	width inside	thickness	height	length inside	weight each
mm	a mm	b mm	c mm	d mm	e mm	f mm	kg
10	12	84	23	4	8	24	0.26
12	15	95	27	5	10	31	0.42
14	17	100	27	5	10	38	0.48
16	19	112	32	5	12	46	0.61
18	22	125	35	5	15	47	0.95
22	25	150	45	6	16	61	1.33
24	28	157	45	7	16	56	1.67
26	30	170	47	7	18	68	1.96
32	35	190	60	7	22	73	2.43
36	40	212	70	9	26	80	4.32
38	45	228	70	7	27	94	3.67



## Green Pin® ID Tag

### Aluminium identification tag

- **Material:** aluminium
- **Finish:** see table below
- **Certification:** 2.1

Scan for additional product details

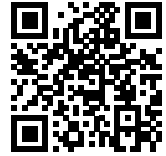

TAG

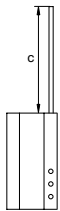
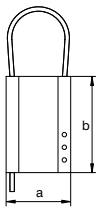

partnumber	finish	width	length	length	weight each
		a mm	b mm	c mm	
TAGVIERGE	self-coloured	51	76	220	0.07
TAGJ	anodized yellow	51	76	220	0.07
TAGGREEN	anodized green	51	76	220	0.07
TAGRED	anodized red	51	76	220	0.07
TAGBLUE	anodized blue	51	76	220	0.07
TAGDEMI	self-coloured	51	38	220	0.04
TAGB without wire rope	self-coloured	51	76		0.06



TAGVIERGE



TAGJ



TAGGREEN



TAGRED



TAGBLUE



TAGDEMI

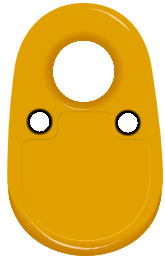

TAGRFID

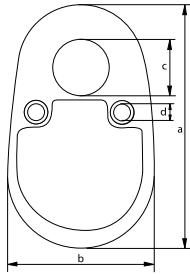

## Green Pin® RFID Tag

### Accessory for radio-frequency identification of slings

- **Material:** stainless steel
- **Standard:** RF Protocol ISO 15693 Operating Frequency HF - 13.56 MHz with individual serial number
- **Finish:** polymer
- **Temperature range:** -40 °C up to +125 °C
- **Certification:** 2.1
- **Note:** IP68; water and ice proof



length	width	diameter	diameter	weight per 100 pcs
a mm	b mm	c mm	d mm	kg
53	33	12	4	1.80

RFID INFO



CHIPRFID

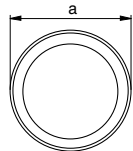

## Green Pin® RFID Chip

### Accessory for radio-frequency identification of slings

- **Material:** polymer
- **Standard:** RF Protocol ISO 15693 Operating Frequency HF - 13.56 MHz with individual serial number
- **Temperature range:** -40 °C up to +125 °C
- **Certification:** 2.1
- **Note:** IP68; water and ice proof

diameter	thickness	weight per 100 pcs
a mm	b mm	kg
6	2	0.02

RFID INFO



## Green Pin® Clevis For Web Sling Connector GR8 Spare Kit

### Grade 8 spare kit for clevis for web sling connector

- **Material:** alloy steel, grade 8, quenched and tempered
- **Finish:** self-coloured
- **Temperature range:** -40 °C up to +200 °C
- **Certification:** 2.1 3.1 CE IIB

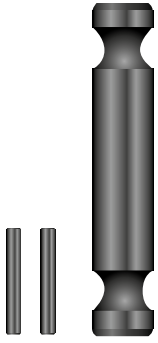

RCOS

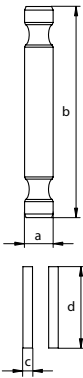

partnumber	diameter pin	length pin	diameter pin	length pin	weight each
	a mm	b mm	c mm	d mm	kg
GPRCOS7/8	9	58	3	22	0.03
GPRCOS10	13	74	4	24	0.08
GPRCOS13	16	94	4	32	0.15
GPRCOS16	20	116	5	35	0.25

partnumber	for fitting	
	COS	XLS
GPRCOS7/8	GPCOS60	
GPRCOS10	GPCOS90	
GPRCOS13	GPCOS150	GPXLS60
GPRCOS16	GPCOS240	



## Green Pin® Connecting Link Spare Kit GR8

### Grade 8 spare kit for connecting link

- **Material:** alloy steel, grade 8, quenched and tempered
- **Finish:** self-coloured
- **Temperature range:** -40 °C up to +200 °C
- **Certification:** 2.1 3.1 CE IIB

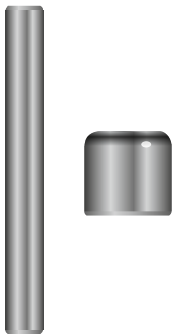

RMJ

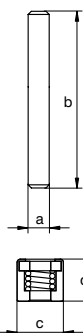

partnumber	diameter pin	length pin	diameter	width	weight each
	a mm	b mm	c mm	d mm	kg
GPRMJ6	5	41	12	10	0.01
GPRMJ7/8	6	54	13	14	0.02
GPRMJ10	8	66	16	18	0.04
GPRMJ13	10	84	22	22	0.10
GPRMJ16	12	105	25	25	0.15
GPRMJ18/20	15	122	28	32	0.25
GPRMJ22	17	141	32	35	0.38
GPRMJ26	20	169	38	40	0.54
GPRMJ32	22	199	45	50	1

partnumber	for fitting	
	MJ	MJS
GPRMJ6	GPMJ6	
GPRMJ7/8	GPMJ7/8	GPMJS7/8
GPRMJ10	GPMJ10	GPMJS10
GPRMJ13	GPMJ13	GPMJS13
GPRMJ16	GPMJ16	
GPRMJ18/20	GPMJ18/20	
GPRMJ22	GPMJ22	
GPRMJ26	GPMJ26	
GPRMJ32	GPMJ32	





# VAN SOEST

Morsestraat 17  
4004 JP Tiel

0344-610607  
info@vansoest-bv.nl

[www.vansoest-bv.nl](http://www.vansoest-bv.nl)

## Green Pin®: the leading brand for premium quality chain and wire rope equipment in the world

- ✓ Premium quality lifting and lashing equipment
- ✓ Supplied with a range of certifications (e.g. DNV, Lloyd's)
- ✓ Unrivalled stock availability of 99%
- ✓ Comprehensive, worldwide support
- ✓ Available in over 100 countries worldwide



Member of



Associated  
Wire Rope  
Fabricators



[greenpin.com](http://greenpin.com)



## CENTREPIECE OF RIGGING

We reserve the right to make amendments on specifications mentioned in this catalogue without prior notification. Specifications show general compliance with the various standards and should not be taken to meet all terms of the contract or purchase order. | Chamber of Commerce Rotterdam, Registration Number 23009317. VAT Number NL 0091.33.835.B01 | © copyright 2024 VAN BEEST B.V., Sliedrecht - All Rights Reserved. | GPCAT24-ENG1