

pewag winner pro points

For safe lifting, load securing and fall protection



pro points advisor

Find the right pewag pro point for your application.
The pewag pro points advisor selects the right pro point for your
operation and industry.

[Start now](#)



Content

Screw-in and weldable lifting points from pewag.

pewag winner pro points lifting points set new standards for the lifting and moving of loads. Our innovative product range offers highest standards when it comes to quality, safety and user-friendliness. All products are compatible with the popular pewag winner lifting chain programme.

pewag group

We are part of the pewag group 4-5

peTAG solution

peTAG solution 6

pewag lifting points at a glance

pewag lifting points at a glance 7-9

Comparison between pewag lifting points / Icons 10-13

Screw-in lifting points

pewag - innovation that is safe as houses 14

Screw-in lifting points 15-50

Calculation of the thread length 29

Weldable hooks and lifting points

Weldable hooks and lifting points 52-59

Anchorage points - fall protection

Anchorage points – fall protection 60-63

The individual pewag solution for your challenge 64-65

Spare parts

Spare parts 66-69

User information

User information 70-71



Full Member

We are part of the **pewag group**

pewag lifting solutions is part of an internationally operating group of companies. Our success story goes back to the year 1479.

WHAT DRIVES US

Through our entrepreneurial spirit - shaped by the joy of innovation - we strive to offer the best solutions for the market. Today and in the future.

The high quality of our brands, products and services, as well as the passionate commitment of our employees are our most valuable assets to exceed customer expectations and to live up to our corporate responsibility towards people and environment.

LEADING TO EXCELLENCE



striving for excellence in **QUALITY**

The values of the pewag group brands are demonstrated by our first-class quality and continuous innovation. You can rely on us.



striving for excellence in **RESPONSIBILITY**

Our goal is CO₂ neutral production by 2030. We live sustainable and fair partnerships and an open way of working together. We take on social as well as environmental responsibility.



striving for excellence in **ENTREPRENEURSHIP**

Through the specific expertise of each individual and decentralized responsibilities, we ensure healthy growth and a sustainably successful future.



striving for excellence in **TECHNOLOGY**

We ensure our technological strength by striving for quality, continuous improvement and innovation of our products and production processes.

FROM AUSTRIA....



1479

First documentary mention of the forge

1787

Foundation of the chain forge in Kapfenberg

1803

Foundation of the location in Graz

1836

Establishment of an iron casting plant in Brückl

1912

Production of the first pewag snow chain

2009

pewag develops into an international group of companies

2021

Extensive investment in renewable energies. Goal: CO₂-neutral production by 2030

....ACROSS THE GLOBE

100+

Countries

50

Sales and other locations

45

Sales partners

18

Production sites

15+

Brands

5

Continents

IN A SUSTAINABLE WAY

Social Excellence

The corporate ethics of the pewag group are based on our clear commitment to universal human rights. As a globally active group of companies, we bear a social and corporate responsibility. This applies in particular to our employees. Their occupational safety and health protection are our top priority. We promote their personal and professional development and foster a culture of open, honest, non-discriminatory and team-oriented exchange based on transparent communication. We apply the same standards in our dealings with customers, suppliers and other business partners.

Environmental Excellence

We are committed to a careful and sustainable approach to the environment. This applies to all areas and activities of our group of companies. For us, it is a matter of course to use resources as efficiently as possible and to ensure this also in the future through new environmentally friendly and efficient processes. We are continuously working to optimize the durability and recyclability of our products. In this context, one of our core concerns is to continuously improve our energy efficiency and thus reduce energy consumption in the long term. The energy we use comes from renewable energy sources and is already partly generated by ourselves.



WHAT DEFINES US



Snow and forestry chains



Hoist and conveyor chains



Do-it-yourself



Engineering



Lifting solutions



Tire protection chains

Our Expertise.

Our international brands have an extensive and diverse range of products and services.

The portfolio ranges from traction chains for tires, tire protection chains for mining vehicles over a wide range of technical chains and innovative lifting solutions up to products for the do-it-yourself area as well as forming technology.

Our Network.

With over 50 locations on five continents, the pewag group forms a global platform of product specialists, partners and suppliers.

This community is strengthened by a large network of external experts from science, research and development and a wide range of brands and companies within the group.

Our Experience.

Based on centuries of experience, genuine craftsmanship and innovative technologies we process the highest quality materials with the claim to offer the best solutions on the market.

What unites us as people within the pewag group is the strong ambition for continuous development.

pewag peTAG solution

Your smart solution for efficient product management

The peTAG solution enables the company-wide, flexible servicing and administration of a wide range of objects.

peTAG solution

The intelligent solution for clear object identification, seamless data transfer, servicing of objects, safe archiving of data, efficient interaction with partner companies and much more.

peTAG manager

PC and mobile end devices work hand in hand with this adaptable, high-performance platform that stands out in any working environment and improves data quality at the same time. Additional, expensive reading devices and manual data transfer belong to the past.



Intelligent software

User-specific adaptation of object data, inspection processes and steps. Automated compilation, dispatch and archiving of inspection reports. Sophisticated authorisation concept.



Save time & money

Efficient documentation of working processes, thereby making daily workflows easier. Seamless data exchange, error-free data communication.



Mobile solution

Direct, location-independent data retrieval (e. g. working load limit, safety information, latest inspection report etc.). Smart servicing of objects via the mobile app. Offline availability.



Linked partnerships

Easy exchange and efficient interaction between service providers, dealers and customers. Improved service and data quality. Increased satisfaction and loyalty.



Always up to date

Access to the latest product data and information. Overview of all inspection data. Documented inspection. Full traceability of the object history.

INNOVATIVE

SOLUTIONS



SOLUTIONS

for Your Needs

Screwable lifting points, weldable lifting and lashing points, weldable hooks, anchorage points.

Variety has a name: pewag! The pro points product portfolio consists of high-quality products that are perfectly suitable for almost any application.

Screwable lifting points

| PLAW alpha | Code | Thread [mm] | Working load limit [kg] |
|---|-------------|-------------|-------------------------|
|  | PLAW 0,3 t | M8 | 300 |
| | PLAW 0,63 t | M10 | 630 |
| | PLAW 1 t | M12 | 1.000 |
| | PLAW 1,5 t | M16 | 1.500 |
| | PLAW 2,5 t | M20 | 2.500 |
| | PLAW 4 t | M24 | 4.000 |
| | PLAW 6 t | M30 | 6.000 |
| | PLAW 7 t | M36 | 7.000 |
| | PLAW 8 t | M36 | 8.000 |
| | PLAW 10 t | M42 | 10.000 |
| | PLAW 15 t | M42 | 15.000 |
| | PLAW 20 t | M48 | 20.000 |

| PLGW gamma | Code | Thread [mm] | Working load limit [kg] |
|--|------------|-------------|-------------------------|
|  | PLGW 0,3 t | M8 | 300 |
| | PLGW 0,5 t | M10 | 500 |
| | PLGW 0,7 t | M12 | 700 |
| | PLGW 1,5 t | M16 | 1.500 |
| | PLGW 2,3 t | M20 | 2.300 |
| | PLGW 3,2 t | M24 | 3.200 |
| | PLGW 4,9 t | M30 | 4.900 |
| | PLGW 7 t | M36 | 7.000 |
| | PLGW 9 t | M42 | 9.000 |
| | PLGW 12 t | M48 | 12.000 |

| PLGW-SN gamma | Code | Thread [mm] | Working load limit [kg] |
|--|---------------|-------------|-------------------------|
|  | PLGW-SN 0,3 t | M8 | 300 |
| | PLGW-SN 0,5 t | M10 | 500 |
| | PLGW-SN 0,7 t | M12 | 700 |
| | PLGW-SN 1,5 t | M16 | 1.500 |
| | PLGW-SN 2,3 t | M20 | 2.300 |
| | PLGW-SN 3,5 t | M24 | 3.500 |
| | PLGW-SN 4,9 t | M30 | 4.900 |

| PLGWI Gamma inox | Code | Thread [mm] | Working load limit [kg] |
|---|-------------|-------------|-------------------------|
|  | PLGWI 0,5 t | M12 | 500 |
| | PLGWI 1 t | M16 | 1.000 |
| | PLGWI 2 t* | M20 | 2.000 |

* Differs from picture shown

| PLDW delta | Code | Thread [mm] | Working load limit [kg] |
|---|------------|-------------|-------------------------|
|  | PLDW 0,3 t | M8 | 300 |
| | PLDW 0,5 t | M10 | 500 |
| | PLDW 0,7 t | M12 | 700 |
| | PLDW 1 t | M14 | 1.000 |
| | PLDW 1,5 t | M16 | 1.500 |
| | PLDW 2,5 t | M20 | 2.500 |
| | PLDW 4 t | M24 | 4.000 |
| | PLDW 5,3 t | M30 | 5.300 |
| | PLDW 6,7 t | M30 | 6.700 |
| | PLDW 8 t | M36 | 8.000 |
| | PLDW 10 t | M42 | 10.000 |
| | PLDW 12 t | M45 | 12.000 |
| | PLDW 13 t | M48 | 13.000 |
| | PLDW 13 t | M52 | 13.000 |
| | PLDW 24 t | M56 | 24.000 |
| | PLDW 40 t | M72 | 40.000 |
| | PLDW 45 t | M80 | 45.000 |
| | PLDW 55 t | M90 | 55.000 |
| | PLDW 55 t | M100 | 55.000 |



pewag winner pro points –
lifting points 2.0

Screwable lifting points

| PLZW-FIX-SP zeta | Code | Thread [mm] | WLL S ¹⁾ =5:1 [kg] | WLL S ¹⁾ =4:1 [kg] |
|---|--------------------|-------------|-------------------------------|-------------------------------|
|  | PLZW-FIX-SP 0,4t* | M8 | 400 | 500 |
| | PLZW-FIX-SP 0,63t* | M10 | 630 | 780 |
| | PLZW-FIX-SP 0,95* | M12 | 950 | 1.180 |
| | PLZW-FIX-SP 1,3t* | M14 | 1.300 | 1.600 |
| | PLZW-FIX-SP 1,8t* | M16 | 1.800 | 2.250 |
| | PLZW-FIX-SP 2,2t* | M18 | 2.200 | 2.750 |
| | PLZW-FIX-SP 2,5t* | M20 | 2.500 | 3.100 |
| | PLZW-FIX-SP 3,7t* | M22 | 3.700 | 4.600 |
| | PLZW-FIX-SP 4t* | M24 | 4.000 | 5.000 |
| | PLZW-FIX-SP 5,4t | M27 | 5.400 | 6.700 |
| | PLZW-FIX-SP 6,3t | M30 | 6.300 | 7.800 |
| | PLZW-FIX-SP 8t | M33 | 8.000 | 10.000 |
| | PLZW-FIX-SP 10t | M36 | 10.000 | 12.500 |
| | PLZW-FIX-SP 13t | M42 | 13.000 | 16.200 |
| | PLZW-FIX-SP 15t | M48 | 15.000 | 18.700 |

¹⁾ S= Safety Factor

*Also available in the easily dismantlable version as PLZW.

| PLZW zeta rapid | Code | Thread [mm] | Working load limit [kg] |
|---|-------------|-------------|-------------------------|
|  | PLZW-R 0,4t | M10 | 400 |
| | PLZW-R 0,5t | M12 | 500 |
| | PLZW-R 1,1t | M16 | 1.100 |
| With an exclusive Click-and-Go function | | | |

| PLZW-DW DW15 | Code | Thread [mm] | Working load limit [kg] |
|---|------------|-------------|-------------------------|
|  | PLZW-DW 15 | DW 15 | 3600 |

| PLOW omega | Code | Thread [mm] | Working load limit [kg] |
|---|------------|-------------|-------------------------|
|  | PLOW 0,4 t | M8 | 400 |
| | PLOW 0,8 t | M10 | 800 |
| | PLOW 1,2 t | M12 | 1.200 |
| | PLOW 2 t | M16 | 2.000 |
| | PLOW 3,4 t | M20 | 3.400 |
| | PLOW 4,7 t | M24 | 4.700 |

| PLTW theta | Code | Thread [mm] | Working load limit [kg] |
|--|------------|-------------|-------------------------|
|  | PLTW 3,15t | M16 | 3.150 |
| | PLTW 4,5t | M20 | 4.500 |
| | PLTW 10t | M30 | 10.000 |
| | PLTW 16t | M36 | 16.000 |

| RGS Eyebolt | Code | Thread [mm] | Working load limit [kg] |
|--|--------|-------------|-------------------------|
|  | RGS 8 | M8 | 400 |
| | RGS 10 | M10 | 700 |
| | RGS 12 | M12 | 1.000 |
| | RGS 14 | M14 | 1.200 |
| | RGS 16 | M16 | 1.500 |
| | RGS 20 | M20 | 2.500 |
| | RGS 24 | M24 | 4.000 |
| | RGS 30 | M30 | 6.000 |
| | RGS 36 | M36 | 8.000 |
| | RGS 42 | M42 | 10.000 |
| | RGS 48 | M48 | 18.000 |

Weldable lifting and lashing points and weldable hooks

| PLE/N eta | Code | Working load limit [kg] |
|-----------|----------|-------------------------|
| | PLE/N 6 | 1.120 |
| | PLE/N 8 | 2.000 |
| | PLE/N 10 | 3.150 |
| | PLE/N 13 | 5.300 |
| | PLE/N 16 | 8.000 |
| | PLE/N 22 | 15.000 |

| PLEW eta | Code | Working load limit [kg] |
|----------|------------------------------|-------------------------|
| | PLEW 1,5 t <small>CR</small> | 1.500 |
| | PLEW 2,5 t <small>CR</small> | 2.500 |
| | PLEW 4 t <small>CR</small> | 4.000 |
| | PLEW 6,7 t | 6.700 |
| | PLEW 10 t | 10.000 |
| | PLEW 19 t | 19.000 |

CR = The PLEW is available in selected sizes as a CRYO variant

| PLEW-LC eta | Code | Max. lashing capacity LC [daN] |
|-------------|---------------|--------------------------------|
| | PLEW-LC 3000 | 3.000 |
| | PLEW-LC 5000 | 5.000 |
| | PLEW-LC 8000 | 8.000 |
| | PLEW-LC 13400 | 13.400 |
| | PLEW-LC 20000 | 20.000 |

| RoRo | Code | Lashing capacity [daN] |
|------|-----------------|------------------------|
| | Ro-Ro 10.000daN | 10.000 |

| PLKW kappa | Code |
|------------|-----------|
| | PLKW BG10 |
| | PLKW BG13 |
| | PLKW BG16 |
| | PLKW BG20 |
| | PLKW BG28 |

| AWHW Weld-on hook | Code | Working load limit [kg] |
|-------------------|----------|-------------------------|
| | AWHW 1,3 | 1.300- |
| | AWHW 3,8 | 3.800- |
| | AWHW 6,3 | 6.300- |
| | AWHW 10 | 10.000- |

Anchorage points - fall protection

| PLGW-PSA Fall protection | Code | Persons |
|--------------------------|--------------|---------|
| | PLGW PSA M12 | 1 |
| | PLGW PSA M16 | 2 |
| | PLGW PSA M20 | 2 |

Stainless anchorage points - fall protection











| PLGWI-PSA Fall protection | Code | Persons |
|---------------------------|---------------|---------|
| | PLGWI PSA M12 | 1 |
| | PLGWI PSA M16 | 2 |



Use our service and explore the individual pro points in detail through the 3D animation!

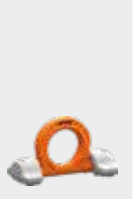









Comparison between pewag lifting points / Icons

| |  |  |  |  |  |  |  |  |  |
|--|---|---|---|---|--|---|---|---|---|
| | PLAW alpha | PLGW gamma | PLGW-SN gamma | PLGWI gamma inox | PLDW delta | PLZW- FIX-SP zeta | PLZW zeta rapid | PLZW-DW DW15 | PLOW omega |
|  Optionally available with pewag peTAG NFC chip | ✓ | ✓ | ✓ | ✓ | ✓ | ✓ | ✓ | ✓ | ✓ |
|  Spare parts are available | ✓ | ✓ | ✓ | - | - | ✓ | - | - | ✓ |
|  Maximum and special length | ✓ | ✓ | - | ✓ | ✓ | ✓ | - | - | ✓ |
|  Available with a metric thread | ✓ | ✓ | ✓ | ✓ | ✓ | ✓ | ✓ | - | ✓ |
|  Available with an UNC thread | ✓ | ✓ | - | - | ✓ | ✓ | - | - | - |
|  Optional with PIP identification plug / colour marking | ✓ | ✓ | ✓ | ✓ | ✓ | ✓ | ✓ | ✓ | ✓ |
|  Comes with an individual serial number | ✓ | ✓ | ✓ | ✓ | ✓ | ✓ | ✓ | ✓ | ✓ |
|  Anti-corrosion coating | ✓ | ✓ | ✓ | - | ✓ | ✓ | ✓ | ✓ | ✓ |
|  Developed and manufactured in Europe | ✓ | ✓ | ✓ | ✓ | ✓ | ✓ | ✓ | ✓ | ✓ |
|  May be used with a PLGIS Allen key | - | ✓ | - | ✓ | - | - | - | - | - |
|  Crack-tested screw | ✓ | ✓ | ✓ | ✓ | - | ✓ | - | - | ✓ |
|  Safety factor 4:1 | ✓ | ✓ | ✓ | ✓ | ✓ | - | - | - | ✓ |
|  Safety factor 5:1 | - | - | - | - | - | ✓ | ✓ | - | - |
|  Torque marking | - | - | - | - | ✓ | ✓ | ✓ | ✓ | ✓ |

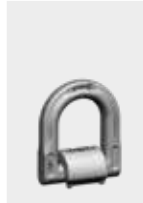
|  |  |  |  |  |  |  |  |  |  |
|--|---|---|---|---|---|--|---|---|---|
| PLTW theta | RGS eyebolt | PLE/N eta | PLEW eta | PLEW-LC eta | RoRo | PLKW kappa | AWHW weld-on hook | PLGW-PSA fall protection | PLGWI-PSA fall protection |
| - | - | - | ✓ | ✓ | - | - | - | ✓ | ✓ |
| - | - | - | - | - | - | - | ✓ | ✓ | - |
| - | - | - | - | - | - | - | - | ✓ | ✓ |
| ✓ | ✓ | - | - | - | - | - | - | ✓ | ✓ |
| - | - | - | - | - | - | - | - | - | - |
| - | - | - | ✓ | ✓ | - | - | - | ✓ | ✓ |
| ✓ | - | - | ✓ | - | - | ✓ | - | ✓ | ✓ |
| ✓ | ✓ | ✓ | ✓ | - | - | ✓ | ✓ | ✓ | ✓ |
| ✓ | - | ✓ | ✓ | ✓ | ✓ | ✓ | ✓ | ✓ | ✓ |
| - | - | - | - | - | - | - | - | ✓ | ✓ |
| ✓ | - | - | - | - | - | - | - | ✓ | ✓ |
| ✓ | ✓ | ✓ | ✓ | - | - | ✓ | ✓ | - | - |
| - | - | - | - | - | - | - | - | - | - |
| ✓ | - | - | - | - | - | - | - | - | - |

Comparison between pewag lifting points / Icons

| |  |  |  |  |  |  |  |  |  |
|--|---|---|---|---|---|---|---|---|---|
| | PLAW alpha | PLGW gamma | PLGW-SN gamma | PLGWI gamma inox | PLDW delta | PLZW- FIX-SP zeta | PLZW zeta rapid | PLZW-DW DW15 | PLOW omega |
|  Special colours available upon request | ✓ | ✓ | ✓ | ✓ | ✓ | ✓ | ✓ | ✓ | ✓ |
|  3D CAD Drawings available | ✓ | ✓ | ✓ | ✓ | ✓ | ✓ | ✓ | ✓ | ✓ |
|  Products made from stainless steel / rust-resistant | - | - | - | ✓ | - | - | - | - | - |
|  Personal protection equipment | - | - | - | - | - | - | - | - | - |
|  Ring adjustable in any position (spring function) | ✓ | - | - | - | - | ✓ optional | - | - | - |
|  Screw is exchangeable | ✓ | ✓ | - | ✓ | - | ✓ | - | - | - |
|  Patented | ✓ | ✓ | ✓ | - | - | ✓ | - | - | ✓ |
|  Customised and maximal length manufactured within 24 h | ✓ | ✓ | - | ✓ | ✓ | ✓ | - | - | ✓ |
|  Online training available via pewag academy | ✓ | ✓ | ✓ | - | ✓ | ✓ | ✓ | ✓ | ✓ |
|  Ring may be removed without tools | - | - | - | - | - | ✓ | - | - | - |
|  360° rotatable | ✓ | ✓ | ✓ | ✓ | ✓ | ✓ | ✓ | ✓ | ✓ |
|  Rotatable under load | - | - | - | - | ✓ | - | - | - | ✓ |
|  Tool-free assembly possible | - | ✓ | ✓ | - | - | - | ✓ | - | ✓ |
|  -40°C | ✓ | ✓ | ✓ | ✓ | ✓ | - | - | - | - |
|  -20°C | - | - | - | - | - | ✓ | ✓ | ✓ | ✓ |

|  |  |  |  |  |  |  |  |  |  |
|--|---|---|---|---|---|--|---|---|---|
| PLTW theta | RGS eyebolt | PLE/N eta | PLEW eta | PLEW-LC eta | RoRo | PLKW kappa | AWHW weld-on hook | PLGW-PSA fall protection | PLGWI-PSA fall protection |
| ✓ | - | ✓ | ✓ | ✓ | - | ✓ | - | - | - |
| ✓ | ✓ | ✓ | ✓ | ✓ | ✓ | ✓ | ✓ | ✓ | ✓ |
| - | - | - | - | - | - | - | - | - | ✓ |
| - | - | - | - | - | - | - | - | ✓ | ✓ |
| - | - | ✓ | ✓ | ✓ | - | - | - | - | - |
| ✓ | - | - | - | - | - | - | - | ✓ | ✓ |
| - | - | - | - | - | - | ✓ | - | ✓ | - |
| - | - | - | - | - | - | - | - | ✓ | ✓ |
| ✓ | ✓ | ✓ | ✓ | - | - | ✓ | - | ✓ | ✓ |
| ✓ | - | - | - | - | - | - | - | - | - |
| - | - | - | - | - | - | - | - | ✓ | ✓ |
| - | - | - | - | - | - | - | - | - | - |
| - | ✓ | - | - | - | - | - | - | ✓ | - |
| - | ✓ | - | ✓ | - | ✓ | - | ✓ | ✓ | ✓ |
| ✓ | - | ✓ | - | ✓ | - | ✓ | - | - | - |

pewag – innovation that is safe and reliable

Lifting and lashing: the highest level of safety for operating staff and goods to be transported.

As a European premium chain manufacturer, pewag has always been synonymous with innovation, quality and safety, presenting innovations and defining new standards on a continuous basis.

The pewag winner pro points range of lifting points stands out for its excellent compatibility with the pewag winner lifting chains that are used extensively on a global scale. pewag winner pro points lifting points comply with Machine Directive 2006/42/EC and/or Machine Safety Regulation 2010, EN 1677-1 as well as with technical specifications. Sophisticated design makes this innovative range complete. The pewag winner pro points lifting points are produced in our ISO 9001 and 14001 certified plants and guarantee a 4- respectively 5-fold safety and a maximum dynamic load of min. 20.000 load cycles, tested at 1,5 times the working load limit.

Working load limits will vary according to the type of application, number of legs and angle of inclination and are listed in tables, which form an integral part of the detailed user manual that each lifting point comes with. Our website www.pewag.com also contains detailed information on working load limits, dimensions etc. as well as downloadable 3D models for design engineers.



Laser engraved marking of the serial number



Testing in the pewag lab

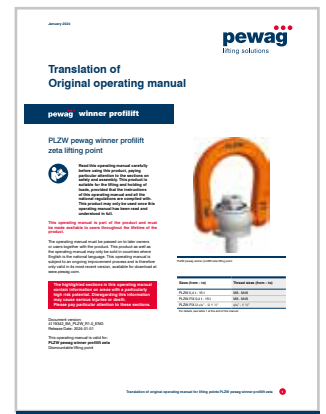

Original operating manual in compliance with Machine Directive EC

**pewag winner pro points –
our products master
any challenge.**



pewag PLAW alpha



This lifting point is 360° rotatable. The load ring is rotatable across a wide range and can be positioned at any required angle due to its replaceable and patented spring. The hexagonal special screw is also replaceable and secured against loss. The PLAW pewag winner pro points alpha screw is made from 10,9 grade material, 100% crack-tested, covered with a chromate VI-free protection agent against corrosion and marked with the working load limit and thread size.

The pewag winner pro points alpha screw is able to withstand a 4-fold safety factor against breakage in all directions and every single lifting point is marked with an individual serial number. pewag winner pro points alpha is available with metric or UNC-thread. The versions with metric thread are also available with customised thread lengths. All working load limits, categorised by type of application, the number of legs and angle of inclination, are contained in a table that forms an integral part of the operating manual included with each lifting point.

Optionally also available with peTAG (NFC chip) or PIP (colour marking).



PLAW 0,3 t - 1,5 t and PLAW 4 t



PLAW 2,5 t - 20 t



PLAW 2,5 t - 20 t

Permitted usage

For working load limits in the permitted directions of pull, please refer to the working load limit table.

Non-permitted usage

During assembly, ensure that improper loading does not arise due to any of the following factors:

- Direction of pull is obstructed
- Direction of pull is not within the indicated area
- Loading ring rests against edges or surfaces

The loading ring must be placed in the direction of pull before loading – do not turn under load! For additional details and information, please refer to the full operating manual.

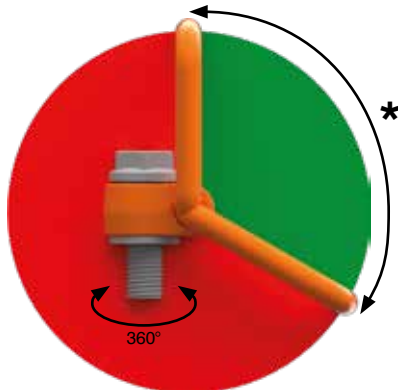

Permissible load directions



Non-permissible load directions



Improper loading as loading ring rests against edges or surfaces

pewag PLAW alpha

Method of lifting
Number of legs
Angle of inclination

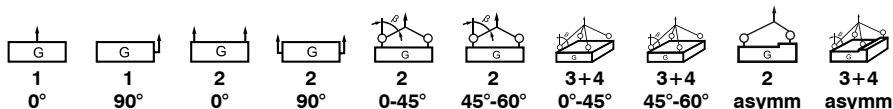

| Code | Thread [mm] | Torque [Nm] | Working load limit (G) [kg] | | | | | | | | | |
|-------------|-------------|-------------|-----------------------------|--------|--------|--------|--------|--------|--------|--------|--------|--------|
| | | | 1 | 1 | 2 | 2 | 2 | 2 | 3+4 | 3+4 | 2 | 3+4 |
| PLAW 0,3 t | M8 | 35 | 300 | 300 | 600 | 600 | 400 | 300 | 600 | 400 | 300 | 300 |
| PLAW 0,63 t | M10 | 70 | 630 | 630 | 1.260 | 1.260 | 850 | 630 | 1.300 | 900 | 630 | 630 |
| PLAW 1 t | M12 | 120 | 1.000 | 1.000 | 2.000 | 2.000 | 1.400 | 1.000 | 2.100 | 1.500 | 1.000 | 1.000 |
| PLAW 1,5 t | M16 | 150 | 1.500 | 1.500 | 3.000 | 3.000 | 2.100 | 1.500 | 3.100 | 2.200 | 1.500 | 1.500 |
| PLAW 2,5 t | M20 | 170 | 2.500 | 2.500 | 5.000 | 5.000 | 3.500 | 2.500 | 5.300 | 3.700 | 2.500 | 2.500 |
| PLAW 4 t | M24 | 400 | 4.000 | 4.000 | 8.000 | 8.000 | 5.600 | 4.000 | 8.400 | 6.000 | 4.000 | 4.000 |
| PLAW 6 t | M30 | 500 | 6.000 | 6.000 | 12.000 | 12.000 | 8.500 | 6.000 | 12.700 | 9.000 | 6.000 | 6.000 |
| PLAW 7 t | M36 | 700 | 7.000 | 7.000 | 14.000 | 14.000 | 9.800 | 7.000 | 14.800 | 10.500 | 7.000 | 7.000 |
| PLAW 8 t | M36 | 800 | 8.000 | 8.000 | 16.000 | 16.000 | 11.300 | 8.000 | 16.900 | 12.000 | 8.000 | 8.000 |
| PLAW 10 t | M42 | 1.500 | 10.000 | 10.000 | 20.000 | 20.000 | 14.000 | 10.000 | 21.000 | 15.000 | 10.000 | 10.000 |
| PLAW 15 t | M42 | 1.500 | 15.000 | 15.000 | 30.000 | 30.000 | 21.000 | 15.000 | 31.500 | 22.500 | 15.000 | 15.000 |
| PLAW 20 t | M48 | 2.000 | 20.000 | 20.000 | 40.000 | 40.000 | 28.000 | 20.000 | 42.000 | 30.000 | 20.000 | 20.000 |

| Code | Thread [inch] | Torque [ft-lbs] | Working load limit (G) [lbs] | | | | | | | | | |
|-------------|---------------|-----------------|------------------------------|--------|--------|--------|--------|--------|--------|--------|--------|--------|
| | | | 1 | 1 | 2 | 2 | 2 | 2 | 3+4 | 3+4 | 2 | 3+4 |
| PLAW U3/8 | 3/8"-16 | 51,6 | 1.400 | 1.400 | 2.800 | 2.800 | 1.980 | 1.400 | 2.970 | 2.100 | 1.400 | 1.400 |
| PLAW U1/2 | 1/2"-13 | 88,5 | 2.200 | 2.200 | 4.400 | 4.400 | 3.000 | 2.200 | 4.600 | 3.300 | 2.200 | 2.200 |
| PLAW U5/8 | 5/8"-11 | 110 | 3.300 | 3.300 | 6.600 | 6.600 | 4.600 | 3.300 | 6.800 | 4.800 | 3.300 | 3.300 |
| PLAW U3/4 | 3/4"-10 | 125 | 5.500 | 5.500 | 11.000 | 11.000 | 7.700 | 5.500 | 11.600 | 8.250 | 5.500 | 5.500 |
| PLAW U1 | 1"-8 | 295 | 8.800 | 8.800 | 17.600 | 17.600 | 12.300 | 8.800 | 18.400 | 13.200 | 8.800 | 8.800 |
| PLAW U1 1/4 | 1 1/4"-7 | 369 | 13.200 | 13.200 | 26.400 | 26.400 | 18.700 | 13.200 | 27.800 | 19.800 | 13.200 | 13.200 |
| PLAW U1 1/2 | 1 1/2"-6 | 590 | 17.600 | 17.600 | 35.200 | 35.200 | 24.800 | 17.600 | 37.300 | 26.400 | 17.600 | 17.600 |
| PLAW U1 3/4 | 1 3/4"-5 | 740 | 22.000 | 22.000 | 44.000 | 44.000 | 30.000 | 22.000 | 45.000 | 33.000 | 22.000 | 22.000 |

Note: The UNC option is available upon request. If you have any questions, please feel free to contact us.

Safety factor 4:1

| | |
|--|---|
| <p>Straight pull 0°</p> | <p>Lateral load direction „permitted“ (ring is aligned) 90°</p> |
| | |
| <p>Nominal working load limit for loading along the screw axis (column "0°" in the working load limit table)</p> | <p>Nominal working load limit for loading vertically to the screw axis (column "90°" in the working load limit table)</p> |

| Code | Thread [mm] | WLL [kg] | a [mm] | b [mm] | c [mm] | d [mm] | e [mm] | f [mm] | g [mm] | l [mm] | n [mm] | n max [mm] | ⌀ [mm] | ⊥ [mm] | Weight [kg/unit] |
|-------------|-------------|----------|--------|--------|--------|--------|--------|--------|--------|--------|------------------|------------|--------|--------|------------------|
| PLAW 0,3 t | M8 | 300 | 45 | 67 | 11 | 41 | 95 | 36 | 40 | 55 | 20 | 150 | 10 | 24 | 0,57 |
| PLAW 0,63 t | M10 | 630 | 45 | 67 | 11 | 41 | 95 | 36 | 40 | 55 | 20 | 150 | 10 | 24 | 0,58 |
| PLAW 1 t | M12 | 1.000 | 45 | 67 | 11 | 41 | 95 | 36 | 40 | 55 | 20 ¹⁾ | 170 | 10 | 24 | 0,60 |
| PLAW 1,5 t | M16 | 1.500 | 45 | 67 | 11 | 41 | 95 | 36 | 40 | 55 | 24 ¹⁾ | 260 | 10 | 24 | 0,60 |
| PLAW 2,5 t | M20 | 2.500 | 54 | 81 | 13 | 55 | 112 | 50 | 50 | 67 | 33 | 335 | 8 | 24 | 1,10 |
| PLAW 4 t | M24 | 4.000 | 54 | 87 | 17 | 67 | 142 | 45 | 50 | 70 | 36 | 361 | 14 | 36 | 1,60 |
| PLAW 6 t | M30 | 6.000 | 68 | 108 | 20 | 68 | 148 | 55 | 60 | 85 | 45 | 360 | 14 | 36 | 2,50 |
| PLAW 7 t | M36 | 7.000 | 75 | 115 | 20 | 65 | 143 | 60 | 67 | 100 | 55 | 374 | 27 | - | 3,30 |
| PLAW 8 t | M36 | 8.000 | 93 | 147 | 27 | 87 | 188 | 85 | 85 | 120 | 55 | 365 | 19 | 41 | 3,80 |
| PLAW 10 t | M42 | 10.000 | 93 | 147 | 27 | 87 | 188 | 85 | 85 | 120 | 65 | 365 | 19 | 41 | 4,80 |
| PLAW 15 t | M42 | 15.000 | 115 | 181 | 33 | 108 | 246 | 106 | 105 | 150 | 63 | 340 | 19 | 55 | 12,00 |
| PLAW 20 t | M48 | 20.000 | 115 | 181 | 33 | 108 | 246 | 106 | 105 | 150 | 73 | 340 | 19 | 55 | 12,30 |

| Code | Thread [inch] | WLL [lbs] | a [inch] | b [inch] | c [inch] | d [inch] | e [inch] | f [inch] | g [inch] | l [inch] | n [inch] | n max [inch] | ⌀ [inch] | ⊥ [inch] | Weight [lbs/pc.] |
|--------------|---------------|-----------|----------|----------|----------|----------|----------|----------|----------|----------|----------|--------------|----------|----------|------------------|
| PLAW U 3/8 | 3/8"-16 | 1.400 | 1,77 | 2,64 | 0,43 | 1,61 | 3,72 | 1,42 | 1,57 | 2,17 | 0,79 | - | 3/8" | 15/16" | 1,30 |
| PLAW U 1/2 | 1/2"-13 | 2.200 | 1,77 | 2,64 | 0,43 | 1,61 | 3,72 | 1,42 | 1,57 | 2,17 | 1,30 | - | 3/8" | 15/16" | 1,32 |
| PLAW U 5/8 | 5/8"-11 | 3.300 | 1,77 | 2,64 | 0,43 | 1,61 | 3,72 | 1,42 | 1,57 | 2,17 | 1,30 | - | 3/8" | 15/16" | 1,39 |
| PLAW U 3/4 | 3/4"-10 | 5.500 | 2,13 | 3,19 | 0,51 | 2,17 | 5,59 | 1,77 | 1,97 | 2,64 | 1,30 | - | 3/8" | 1 1/8" | 2,40 |
| PLAW U 1 | 1"-8 | 8.800 | 2,13 | 3,43 | 0,67 | 2,60 | 5,59 | 1,77 | 1,97 | 2,76 | 1,42 | - | 9/16" | 1 1/2" | 3,50 |
| PLAW U 1 1/4 | 1 1/4"-7 | 13.200 | 2,95 | 4,53 | 0,79 | 2,68 | 5,63 | 2,64 | 2,64 | 3,94 | 1,93 | - | 7/8" | - | 6,80 |
| PLAW U 1 1/2 | 1 1/2"-6 | 17.000 | 3,66 | 5,79 | 1,06 | 3,35 | 7,40 | 3,35 | 3,35 | 4,72 | 2,17 | - | 1 1/2" | 3/4" | 13,70 |
| PLAW U 1 3/4 | 1 3/4"-5 | 22.000 | 3,66 | 5,79 | 1,06 | 3,43 | 7,40 | 3,35 | 3,35 | 4,72 | 2,44 | - | 1 1/4" | - | 14,10 |

Note: The UNC option is available upon request. If you have any questions, please feel free to contact us.

Safety factor 4:1

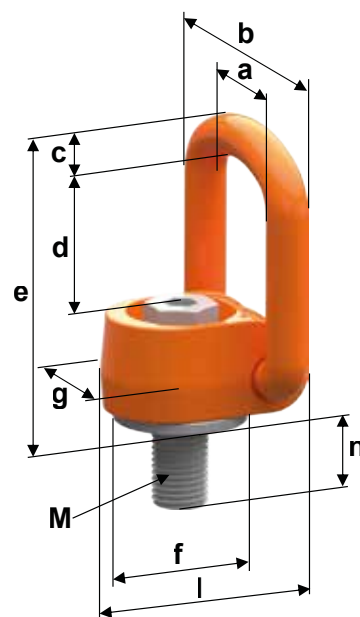

pewag PLGW gamma



The PLGW gamma lifting point was developed and manufactured according to the latest standards. Simply tighten by hand, then align in the load direction - a system that is ideally suited for frequent assembly/disassembly. This patented system has been a great success from the word go and offers unsurpassed ease-of-use.

The eyebolt is 360° rotatable, comes with an interchangeable special screw that is 100% crack-tested as well as chrome VI-free finish-protection against corrosion and is marked with the working load limit and the thread size. The surface of the load is protected by an integrated sleeve. The batch number displayed on all load-bearing parts such as the eye and screws as well as the serial number make identification, traceability and performance of mandatory, regular inspections easier than ever.

PLGW supreme: tool-free assembly and disassembly

Latch in position 1: The latch is not in direct contact with the screw (fig. PLGW supreme rotatable)

- The latch is held in place with a patented spring.
- The eyebolt is rotatable.

Latch in position 2: The latch is in direct contact with the screw (fig. PLGW supreme assembly/disassembly)

- The latch is held in place with a patented spring.
- Eyebolt is not rotatable i.e. the fastening torque is transmitted to the screw and thus the eyebolt can be (re)assembled.

PLGW basic:

A simplified alternative is the pewag PLGW pewag winner pro points gamma basic. Offering the same benefits as the pewag PLGW supreme in terms of measurement, working load limit and application, the pewag PLGW basic differs solely when it comes to assembly: Mounting and removing requires the use of a hexagon Allen wrench. A special Allen key for the sizes M8 - M20 is available upon request.

Optionally also available with peTAG (NFC chip) or PIP (colour marking). The pewag winner pro points gamma is also available with a metric or UNC thread.



PLGW supreme –tool-free handling



PLGW supreme rotatable



PLGW supreme assembly/disassembly



PLGW basic - assembly with tools

Permitted usage

For working load limits in the permitted directions of pull, please refer to the working load limit table. Adjust the lifting point in the permitted load direction before loading.

- Loadable with a 4-fold safety factor against breakage in all directions

Non-permitted usage

During assembly, ensure that improper loading does not arise due to any of the following factors:

- Direction of pull is obstructed
- Direction of pull is not within the indicated area
- Loading ring rests against edges or loads
- Assembly with additional tools (e.g. extension) is not permitted

For additional details and information, please refer to the full operating manual.



Special Allen key - available as a spare part (see page 68)

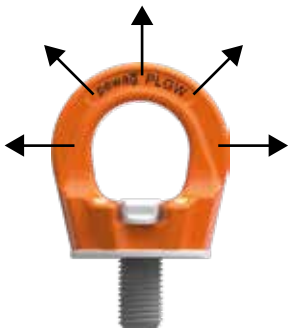

Permitted load directions



Non-permitted load directions

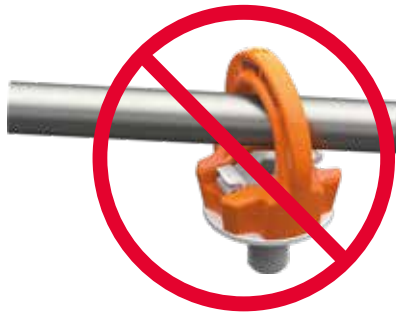

No additional tools permitted

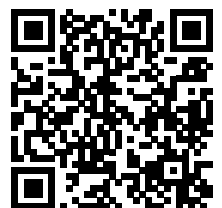

PLGW assembly video / PLGIS

pewag PLGW gamma

Method of lifting
Number of legs
Angle of inclination

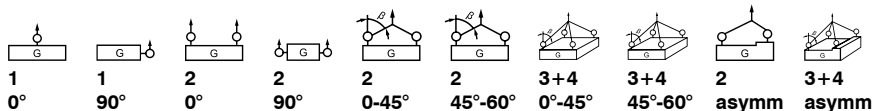

| Code | Thread [mm] | Torque [Nm] | Working load limit (G) | | | | | | | | | |
|------------|-------------|------------------------|------------------------|--------|--------|--------|--------|--------|--------|--------|--------|--------|
| | | | [kg] | | [kg] | | [kg] | | [kg] | | [kg] | |
| PLGW 0,3 t | M8 | Simply tighten by hand | 1.000 | 300 | 2.000 | 600 | 420 | 300 | 630 | 450 | 300 | 300 |
| PLGW 0,5 t | M10 | | 1.500 | 500 | 3.000 | 1.000 | 700 | 500 | 1.060 | 750 | 500 | 500 |
| PLGW 0,7 t | M12 | | 2.000 | 700 | 4.000 | 1.400 | 980 | 700 | 1.480 | 1.050 | 700 | 700 |
| PLGW 1,5 t | M16 | | 4.000 | 1.500 | 8.000 | 3.000 | 2.100 | 1.500 | 3.180 | 2.200 | 1.500 | 1.500 |
| PLGW 2,3 t | M20 | | 5.000 | 2.300 | 10.000 | 4.600 | 3.200 | 2.300 | 4.800 | 3.400 | 2.300 | 2.300 |
| PLGW 3,2 t | M24 | | 6.500 | 3.200 | 13.000 | 6.400 | 4.500 | 3.200 | 6.700 | 4.800 | 3.200 | 3.200 |
| PLGW 4,9 t | M30 | | 12.000 | 4.900 | 24.000 | 9.800 | 6.900 | 4.900 | 10.300 | 7.300 | 4.900 | 4.900 |
| PLGW 7 t | M36 | | 15.000 | 7.000 | 30.000 | 14.000 | 9.800 | 7.000 | 14.800 | 10.500 | 7.000 | 7.000 |
| PLGW 9 t | M42 | | 22.000 | 9.000 | 44.000 | 18.000 | 12.600 | 9.000 | 19.000 | 13.500 | 9.000 | 9.000 |
| PLGW 12 t | M48 | | 30.000 | 12.000 | 60.000 | 24.000 | 16.900 | 12.000 | 25.400 | 18.000 | 12.000 | 12.000 |

| Code | Thread [inch] | Torque [ft-lbs] | Working load limit (G) | | | | | | | | | |
|--------------|---------------|------------------------|------------------------|--------|--------|--------|--------|--------|--------|--------|--------|--------|
| | | | [lbs] | | [lbs] | | [lbs] | | [lbs] | | [lbs] | |
| PLGW U 3/8* | 3/8"-16 | Simply tighten by hand | 2.400 | 1.100 | 4.800 | 2.200 | 1.500 | 1.100 | 2.200 | 1.500 | 1.100 | 1.100 |
| PLGW U 1/2* | 1/2"-13 | | 4.400 | 1.500 | 8.800 | 3.000 | 2.200 | 1.500 | 3.000 | 2.200 | 1.500 | 1.500 |
| PLGW U 5/8* | 5/8"-11 | | 8.800 | 3.300 | 17.600 | 6.600 | 4.600 | 3.300 | 6.600 | 4.800 | 3.300 | 3.300 |
| PLGW U 3/4* | 3/4"-10 | | 9.900 | 4.400 | 19.800 | 8.800 | 6.100 | 4.400 | 9.200 | 6.600 | 4.400 | 4.400 |
| PLGW U 1* | 1"-8 | | 11.000 | 6.600 | 22.000 | 13.200 | 9.200 | 6.600 | 13.600 | 9.900 | 6.600 | 6.600 |
| PLGW U 1 1/4 | 1 1/4"-7 | | 22.000 | 8.800 | 44.000 | 17.600 | 12.300 | 8.800 | 18.000 | 13.200 | 8.800 | 8.800 |
| PLGW U 1 1/2 | 1 1/2"-6 | | 33.000 | 15.400 | 66.000 | 30.800 | 21.500 | 15.400 | 32.300 | 23.100 | 15.400 | 15.400 |
| PLGW U 1 3/4 | 1 3/4"-5 | | 40.000 | 19.800 | 80.000 | 39.600 | 27.700 | 19.800 | 41.500 | 29.700 | 19.800 | 19.800 |

*Available as a standard stock item.

Note: The UNC option is available upon request. If you have any questions, please feel free to contact us.

Safety factor 4:1

| Straight pull 0° | Lateral load direction „permitted“ (ring is aligned) 90° | Lateral load direction “not permitted” |
|--|--|--|
| | | |
| Higher working load limit for loading along the screw axis (column "0°" in the working load limit table) | Nominal working load limit for loading vertically to the screw axis (column "90°" in the working load limit table) | Application not permitted due to unstable conditions. The ring could turn suddenly while under load - high risk for load and/or persons! |

| Code | Thread [mm] | WLL [kg] | a [mm] | b [mm] | c [mm] | d [mm] | e [mm] | f [mm] | n [mm] | n max [mm] | ⊘ [mm] | Weight [kg/unit] |
|------------|-------------|----------|--------|--------|--------|--------|--------|--------|--------|------------|--------|------------------|
| PLGW 0,3 t | M8 | 300 | 25 | 45 | 10 | 27 | 53 | 35 | 15 | 90 | 6 | 0,20 |
| PLGW 0,5 t | M10 | 500 | 25 | 45 | 10 | 27 | 53 | 35 | 15 | 160 | 6 | 0,21 |
| PLGW 0,7 t | M12 | 700 | 30 | 55 | 12 | 32 | 63 | 43 | 20 | 160 | 8 | 0,29 |
| PLGW 1,5 t | M16 | 1.500 | 35 | 64 | 14 | 36 | 70 | 50 | 25 | 160 | 10 | 0,48 |
| PLGW 2,3 t | M20 | 2.300 | 40 | 73 | 16 | 41 | 81 | 54 | 30 | 160 | 12 | 0,58 |
| PLGW 3,2 t | M24 | 3.200 | 50 | 86 | 18 | 50 | 93 | 69 | 35 | - | 14 | 1,10 |
| PLGW 4,9 t | M30 | 4.900 | 60 | 110 | 25 | 60 | 114 | 90 | 45 | - | 17 | 2,20 |
| PLGW 7 t | M36 | 7.000 | 70 | 132 | 31 | 70 | 136 | 108 | 55 | - | 19 | 3,80 |
| PLGW 9 t | M42 | 9.000 | 80 | 152 | 36 | 72 | 153 | 126 | 65 | - | 22 | 5,70 |
| PLGW 12 t | M48 | 12.000 | 95 | 179 | 42 | 88 | 179 | 148 | 75 | - | 24 | 8,90 |

| Code | Thread [inch] | WLL [lbs] | a [inch] | b [inch] | c [inch] | d [inch] | e [inch] | f [inch] | n [inch] | n max [inch] | ⊘ [inch] | Weight [lbs/pc.] |
|--------------|---------------|-----------|----------|----------|----------|----------|----------|----------|----------|--------------|----------|------------------|
| PLGW U 3/8* | 3/8"-16 | 1.100 | 0,98 | 1,77 | 0,39 | 1,06 | 2,09 | 1,38 | 0,59 | - | 1/4" | 0,44 |
| PLGW U 1/2* | 1/2"-13 | 1.500 | 1,18 | 2,17 | 0,47 | 1,26 | 2,48 | 1,69 | 0,79 | - | 5/16" | 0,71 |
| PLGW U 5/8* | 5/8"-11 | 3.300 | 1,38 | 2,52 | 0,55 | 1,42 | 2,76 | 1,97 | 0,98 | - | 3/8" | 0,99 |
| PLGW U 3/4* | 3/4"-10 | 4.400 | 1,57 | 2,87 | 0,63 | 1,61 | 3,19 | 2,13 | 1,18 | - | 1/2" | 1,28 |
| PLGW U 1* | 1"-8 | 6.600 | 1,97 | 3,39 | 0,71 | 1,97 | 3,66 | 2,72 | 1,38 | - | 9/16" | 2,43 |
| PLGW U 1 1/4 | 1 1/4"-7 | 8.800 | 2,36 | 4,33 | 0,98 | 2,36 | 4,49 | 3,54 | 1,77 | - | 5/8" | 4,63 |
| PLGW U 1 1/2 | 1 1/2"-6 | 15.400 | 2,76 | 5,20 | 1,22 | 2,76 | 5,35 | 4,25 | 2,17 | - | 7/8" | 8,38 |
| PLGW U 1 3/4 | 1 3/4"-5 | 19.800 | 3,15 | 5,98 | 1,42 | 2,83 | 6,02 | 4,96 | 2,56 | - | 1" | 12,57 |

*Available as a standard stock item.

Note: The UNC option is available upon request. If you have any questions, please feel free to contact us.

Safety factor 4:1

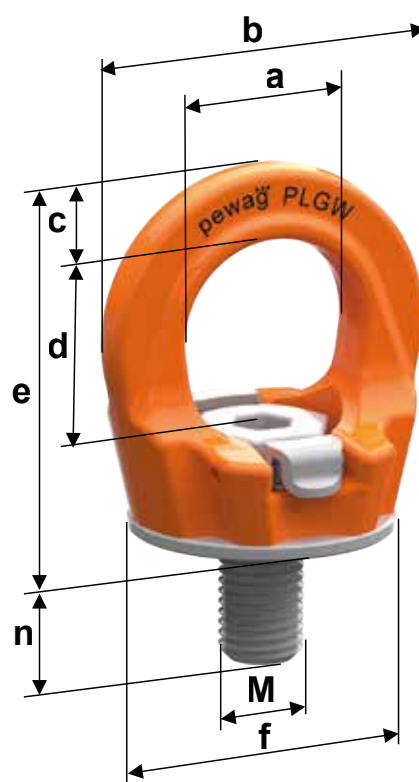

pewag PLGW-SN gamma



This ring nut works on the principle of tool-free assembly, making it unique worldwide. It is the logical continuation of the successful pewag PLGW supreme eyebolt and is used on loads that come with a threaded bolt instead of a thread. Alternatively, the PLGW-SN supreme lifting point may be attached in a through-hole using a standard screw, which has the additional advantage of being able to use the same lifting point with different material thicknesses. This method requires just crack-tested screws (strength category 10,9) of different lengths.

For additional details and information, please refer to the full operating manual.

Other benefits of the PLGW-SN pewag winner pro points gamma supreme lifting point:

- No tools are required for assembly or disassembly
- Saves time especially with frequent assembly/disassembly
- The lifting point is rotatable (may be set in the load direction) and loadable in all directions.

Optionally also available with peTAG (NFC chip) or PIP (colour marking).



Different material thicknesses

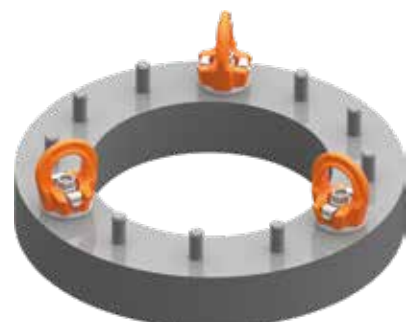

Existing threaded bolts



pewag PLGW SN
Eye nut 3D

Permitted usage

For working load limits in the permitted directions of pull, please refer to the working load limit table. Adjust the lifting point in the permitted load direction before loading.

- Loadable with a 4-fold safety under break in all directions

Non-permitted usage

During assembly, ensure that improper loading does not arise due to any of the following factors:

- Direction of pull is obstructed
- Direction of pull is not within the indicated area
- Loading ring rests against edges or loads

Each lifting point comes with an individual serial number.

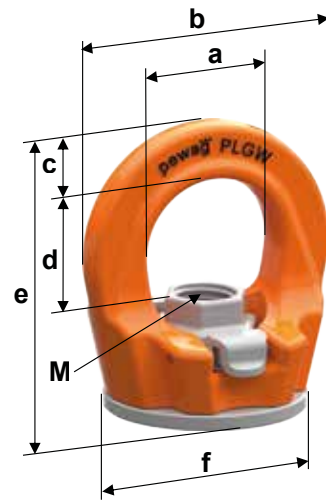

For the corresponding values, see tables with technical data



Permissible load directions



Use of PLGW or PLGW-SN

| Method of lifting | | | | | | | | | | | |
|----------------------|----|-----|----|-----|-------|---------|--------|---------|-------|-------|-------|
| Number of legs | 1 | 1 | 2 | 2 | 2 | 2 | 3+4 | 3+4 | 2 | 3+4 | 3+4 |
| Angle of inclination | 0° | 90° | 0° | 90° | 0-45° | 45°-60° | 0°-45° | 45°-60° | asymm | asymm | asymm |

| Code | Thread [mm] | Working load limit (G) [kg] | | | | | | | | | |
|---------------|-------------|-----------------------------|-------|--------|-------|-------|-------|--------|-------|-------|-------|
| PLGW-SN 0,3 t | M8 | 1.000 | 300 | 2.000 | 600 | 400 | 300 | 600 | 400 | 300 | 300 |
| PLGW-SN 0,5 t | M10 | 1.500 | 500 | 3.000 | 1.000 | 700 | 500 | 1.000 | 700 | 500 | 500 |
| PLGW-SN 0,7 t | M12 | 2.000 | 700 | 4.000 | 1.400 | 1.000 | 700 | 1.400 | 1.000 | 700 | 700 |
| PLGW-SN 1,5 t | M16 | 4.000 | 1.500 | 8.000 | 3.000 | 2.100 | 1.500 | 3.000 | 2.200 | 1.500 | 1.500 |
| PLGW-SN 2,3 t | M20 | 5.000 | 2.300 | 10.000 | 4.600 | 3.200 | 2.300 | 4.800 | 3.400 | 2.300 | 2.300 |
| PLGW-SN 3,5 t | M24 | 6.500 | 3.500 | 13.000 | 7.000 | 4.900 | 3.500 | 7.400 | 5.200 | 3.500 | 3.500 |
| PLGW-SN 4,9 t | M30 | 12.000 | 4.900 | 24.000 | 9.000 | 6.900 | 4.900 | 10.300 | 7.300 | 4.900 | 4.900 |

| Code | Thread [mm] | WLL [kg] | a [mm] | b [mm] | c [mm] | d [mm] | e [mm] | f [mm] | ⌀ [mm] | Weight [kg/unit] |
|---------------|-------------|----------|--------|--------|--------|--------|--------|--------|--------|------------------|
| PLGW-SN 0,3 t | M8 | 300 | 25 | 45 | 10 | 21 | 55 | 35 | 12 | 0,17 |
| PLGW-SN 0,5 t | M10 | 500 | 25 | 45 | 10 | 21 | 55 | 35 | 12 | 0,17 |
| PLGW-SN 0,7 t | M12 | 700 | 30 | 55 | 12 | 25 | 65 | 43 | 14 | 0,28 |
| PLGW-SN 1,5 t | M16 | 1.500 | 35 | 64 | 14 | 29 | 72 | 50 | 19 | 0,42 |
| PLGW-SN 2,3 t | M20 | 2.300 | 40 | 73 | 16 | 34 | 82 | 54 | 22 | 0,50 |
| PLGW-SN 3,5 t | M24 | 3.500 | 50 | 86 | 18 | 40 | 95 | 69 | 27 | 1,00 |
| PLGW-SN 4,9 t | M30 | 4.900 | 60 | 110 | 25 | 47 | 115 | 90 | 36 | 1,90 |

Safety factor 4:1

pewag PLGWI gamma inox

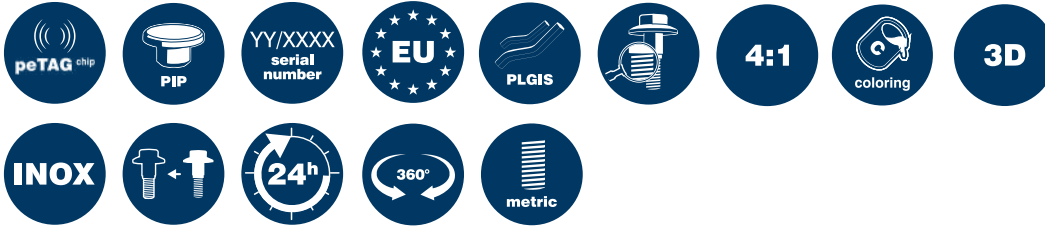

Naturally, the PLGW lifting point is also available in a rust-resistant version – as the PLGWI eye bolt, offering all the tried-and-tested pewag advantages: Versatility when it comes to areas of application, accurately fitted measurements, optimised working load limits and unsurpassed ease-of-use. Please note that a hexagon Allen wrench is required as a tool for mounting and removal.

And the PLGWI offers even more than that:

The eyebolt is 360° rotatable, comes with an interchangeable special screw that is 100% crack-tested and is marked with the working load limit and the thread size!

An integrated sleeve protects the surface of the load. The batch number displayed on all load-bearing parts such as the eye and screws as well as the serial number make identification, traceability and performance of mandatory, regular inspections easier than ever.

Additional benefits of the PLGW inox lifting point:

- Extendable areas of application thanks to Duplex steel with heightened rust-resistance
- The PRE/N value that determines the alloy composition and thus also the level of corrosion-resistance, lies at approx. 34.

Optionally also available with peTAG (NFC chip) or PIP (colour marking).



PLGWI gamma inox M12, M16 - available as a "basic" version (tool for assembly required)



PLGWI gamma inox M20 – available in „basic“ version (tool for assembly required) and „supreme“ version (no tool required for assembly)

Permitted usage

For working load limits in the permitted directions of pull, please refer to the working load limit table.

- Adjust the lifting point in the permitted load direction before loading.
- Loadable with a 4-fold safety under break in all directions.

Non-permitted usage

During assembly, ensure that improper loading does not arise due to any of the following factors:

- Direction of pull is obstructed
- Direction of pull is not within the indicated area
- Loading ring rests against edges or loads.

For additional details and information, please refer to the full operating manual.

Each lifting point comes with an individual serial number.

For detailed information such as lashing type, number of legs, angle of inclination etc., please refer to the tables on the following two pages.



Permissible load directions

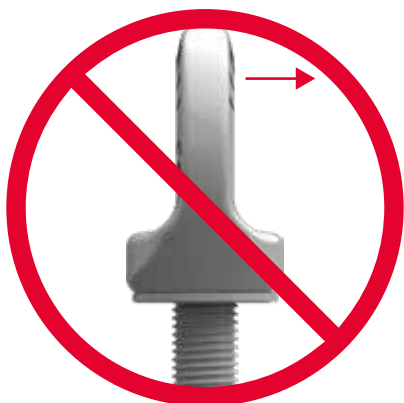

Non-permissible load directions

pewag PLGWI gamma inox

Method of lifting
Number of legs
Angle of inclination

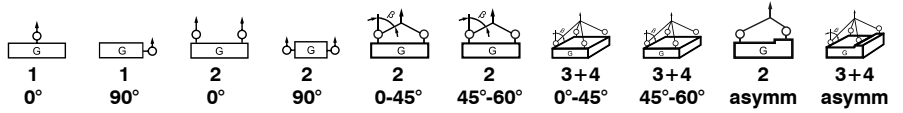

| Code | Thread [mm] | Torque [Nm] | Working load limit (G) [kg] | | | | | | | | | |
|-------------|-------------|-------------|-----------------------------|-------|-------|-------|-------|-------|-------|-------|-------|-------|
| | | | 1 | 1 | 2 | 2 | 2 | 2 | 3+4 | 3+4 | 2 | 3+4 |
| PLGWI 0,5 t | M12 | 25 | 1.500 | 500 | 3.000 | 1.000 | 700 | 500 | 1.060 | 750 | 500 | 500 |
| PLGWI 1 t | M16 | 50 | 3.000 | 1.000 | 6.000 | 2.000 | 1.400 | 1.000 | 2.100 | 1.500 | 1.000 | 1.000 |
| PLGWI 2 t | M20 | 115 | 3.800 | 2.000 | 7.600 | 4.000 | 2.800 | 2.000 | 4.200 | 3.000 | 2.000 | 2.000 |

| Code | Thread [mm] | WLL [kg] | a [mm] | b [mm] | c [mm] | d [mm] | e [mm] | f [mm] | n [mm] | n max [mm] | ⊘ [mm] | Weight [kg/unit] |
|-------------|-------------|----------|--------|--------|--------|--------|--------|--------|--------|------------|--------|------------------|
| PLGWI 0,5 t | M12 | 500 | 30 | 55 | 12 | 30 | 59 | 30 | 18 | 160 | 8 | 0,23 |
| PLGWI 1 t | M16 | 1.000 | 35 | 64 | 14 | 35 | 67 | 35 | 24 | 160 | 10 | 0,36 |
| PLGWI 2 t | M20 | 2.000 | 40 | 72 | 17 | 40 | 80 | 45 | 30 | 160 | 12 | 0,60 |

Safety factor 4:1

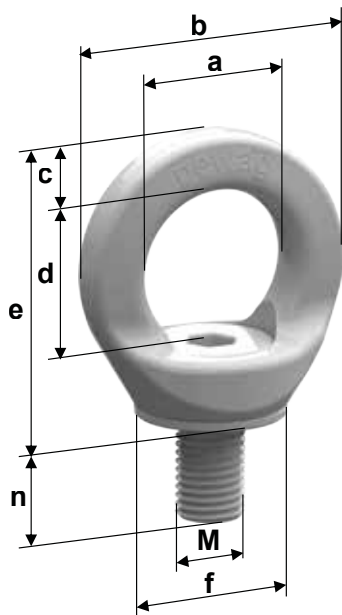

| Straight pull 0° | Lateral load direction „permitted“ (ring is aligned) 90° | Lateral load direction not permitted (ring is not aligned) |
|--|--|--|
| | | |
| Higher working load limit for loading along the screw axis (column "0°" in the working load limit table) | Nominal working load limit for loading vertically to the screw axis (column "90°" in the working load limit table) | Application not permitted due to unstable conditions. The ring could turn suddenly while under load - high risk for load and/or persons! |

pewag pro points lifting points

As individual as your needs.

We supply your lifting point in a customer-specific length (CL) and maximum thread length (MAXL). The set includes washer and screw nut.

The provided screw nuts are:

- Strength category 10
- Manufactured according to DIN 980 V

Calculation of the desired thread length (L):

- L** = $H + S + K + X$
H = Material height
S = Thickness of the washer
K = Height of the nut (Depending on the thread size of the screw)
X = Excess length of the screw (two-fold pitch)
L max. = n max.

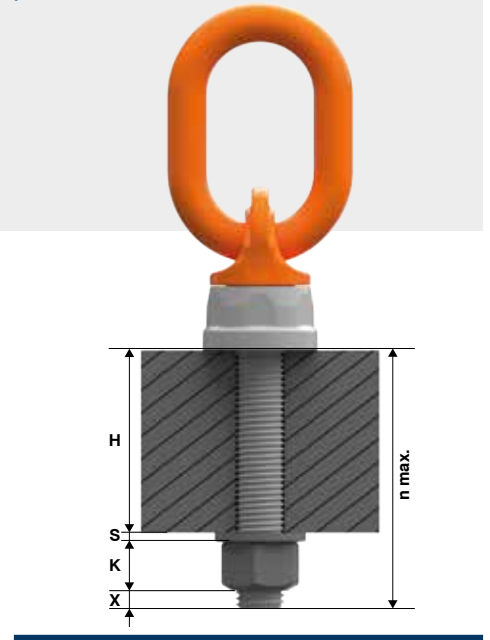

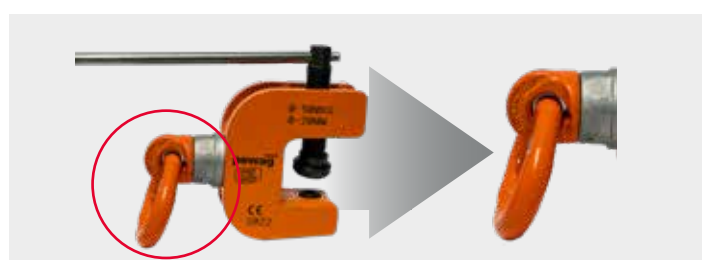
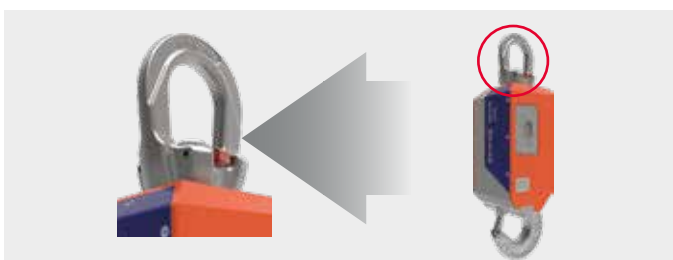
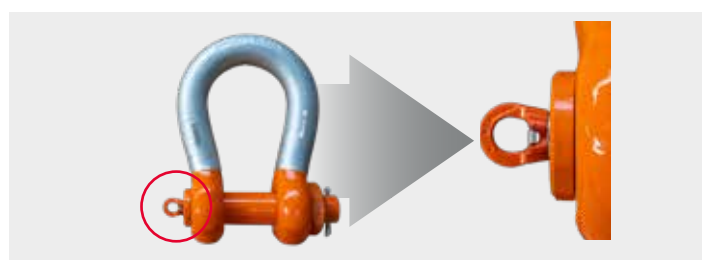

pewag empowers performance

pewag pro points are not only used in demanding lifting applications but are also integrated into other pewag products, enhancing their performance and safety to the highest standard.

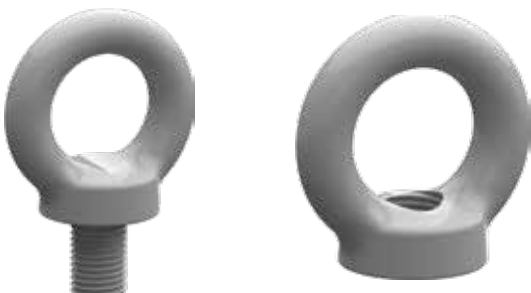

PLGW in comparison: Points in its favour.

- Significantly higher working load limit with the same thread size
- Rotatable by 360°, thus adjustable in the load direction
- Four-fold safety factor against breakage in all directions
- 100 % crack-tested screw

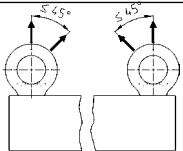
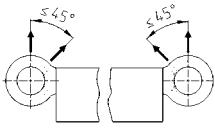
| PLGW eye bolts and/or PLGW-SN eye nut | | | Eye bolt DIN 580 and/or eye nut DIN 582 | | | | |
|---|-------------------------------------|-----------|--|---------|-----------|-------------------|---------|
|  | | |  | | | | |
| | Product | PLGW (SN) | DIN 580 / DIN 582 | | PLGW (SN) | DIN 580 / DIN 582 | |
| | Thread size | M12 | M12 | 1*) 2*) | M36 | M36 | 1*) 2*) |
| | Nominal working load limit | 0,7 t | 0,34 t | | 7 t | 4,6 t | |
|  | WLL | 2 t | 0,34 t | M30 | 15 t | 4,6 t | M64 |
| | Breaking load limit | 8 t | 2,04 t | | 60 t | 27,6 t | |
|  | WLL (< 45°) | 0,7 t | 0,24 t | M20 | 7 t | 3,3 t | M56 |
| | Breaking load limit (< 45°) | 2,8 t | 1,44 t | | 28 t | 19,8 t | |
|  | WLL (< 45° lateral) | 0,7 t | 0,17 t | M24 | 7 t | 2,3 t | M64 |
| | Breaking load limit (< 45° lateral) | 2,8 t | 1,02 t | | 28 t | 13,8 t | |

1*) Refers to the size DIN 580 required to carry the same load as the pewag pro points gamma (in the appropriate direction of loading).

Mode of application: Single-leg, straight pull, load = 2 t, required thread size pewag PLGW: M12, required thread size eye bolt DIN 580: M30

Mode of application: Multi-leg sling

2*) The working load limit of DIN 580 applies only if the screws are screwed in completely and rest on the load with the entire contact surface. Those can always be aligned in the tensile direction. Since it is very likely that at least one screw is loaded in the wrong direction, pewag recommends the adjustable eye bolts PLGW, which may always be aligned with the direction of pull.



Size comparison PLGW M12 – DIN 580-M30

Start Learning Today!



Knowledge For You.



What You Learn

Discover cutting-edge products and the advanced technologies that drive their performance, quality, and durability! At pewag academy, we equip customers, partners, and employees with expert knowledge on installation, safety inspections, and maintenance. We offer valuable insights into key topics like sustainability, cybersecurity, and more. Join us to explore how these innovations are shaping the future and elevate your expertise!



Interactive & Engaging

pewag academy offers a wide range of exciting courses available in both e-learning and blended learning formats. Our experts use a dynamic mix of multimedia teaching methods and innovative didactics to create a truly lasting learning experience. From e-learning to immersive virtual reality, our courses deliver specialized knowledge in an engaging and interactive way. Ready to explore and learn more?



ISO Certified



We ensure the highest quality of teaching materials, validated through our ISO 29993 certification for learning services outside formal education. This certification guarantees that our courses meet international standards for excellence and effectiveness. You can trust that our

programs are designed to provide valuable, practical knowledge that enhances both professional and personal development.

Contact us for more information: academy@pewag.com



pewag PLDW delta

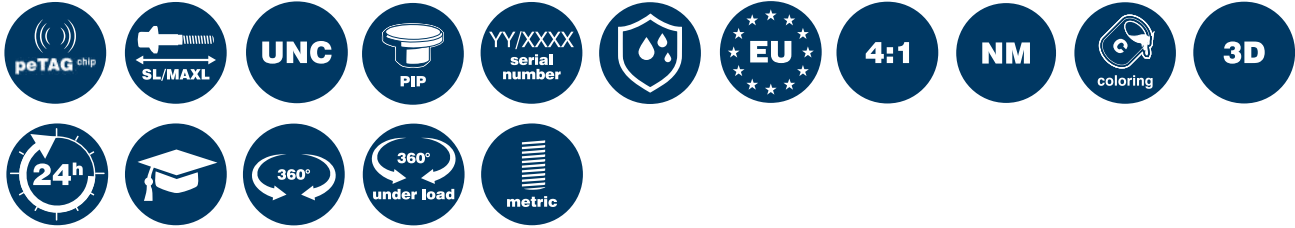

This lifting point comes with a ball bearing and is rotatable by 360° even under load. The high-strength lifting eye is movable by 180°. The special screw is 100% crack-tested, protected against corrosion and marked with the working load limit and thread size. In addition, each lifting point is marked with its own individual serial number. The lifting eye comes with a ring and is wide enough to accommodate even larger hooks.

All working load limits, categorised by lashing type, number of legs and angle of inclination are contained in a table that forms an integral part of the operating manual included with each lifting point. The pewag winner pro points delta lifting points are marked with the admissible working load limit for the most unfavourable application mode, with four-fold safety against break in all directions. In addition, working load limits are higher in case of vertical loading. pewag winner pro points delta is available with a metric or UNC thread, up to a thread size of M100 or a working load limit of 60.000kg.

Optionally also available with peTAG (NFC chip) or PIP (colour marking).

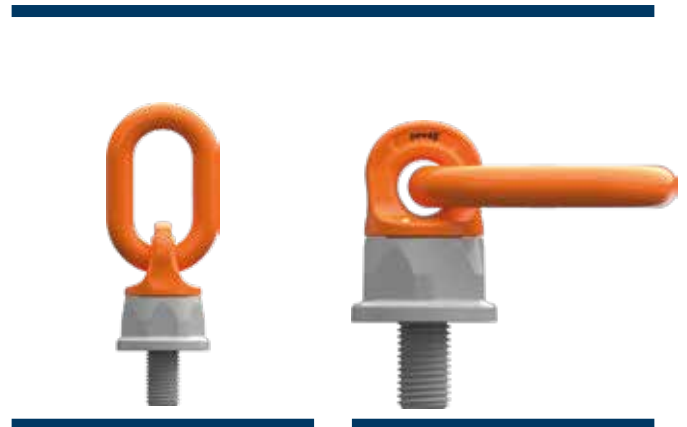

Permitted usage

For working load limits in the permitted directions of pull, please refer to the working load limit table.

Non-permitted usage

During assembly, ensure that improper loading does not arise due to any of the following factors:

- Direction of pull is obstructed
- Direction of pull is not within the indicated area
- Loading ring rests against edges or loads

The lifting points are ball-bearing mounted. However, to prevent the ring from jamming, it is recommended to align it in the permitted and required direction of pull prior to loading (fig. Permitted direction of loading). This is particularly relevant when lifting loads with multi-leg chain slings. If the ring is not aligned (non-permitted loading acc. to fig. 2), the ring holder could suddenly become loose, causing a significant risk to loads and operators.

The full operating manual contains further details and information on safe usage.

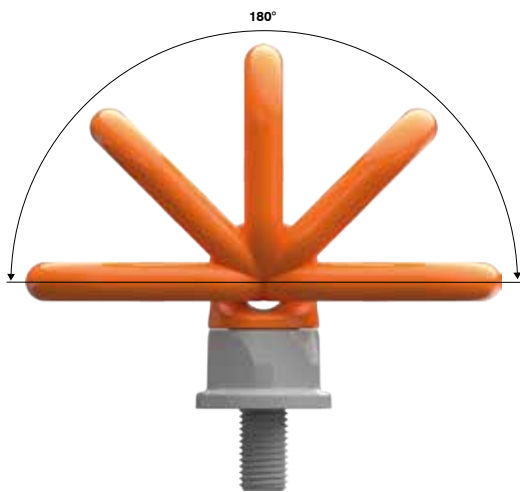

Permissible load directions



Ball-bearing mounted lifting point



Non-permissible load directions

pewag PLDW delta

Method of lifting
Number of legs
Angle of inclination

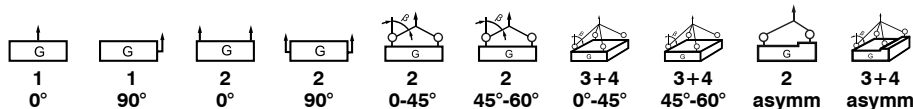





| Code | Thread [mm] | Torque [Nm] | Working load limit (G) | | | | | | | | | |
|----------------|-------------|-------------|------------------------|--------|---------|---------|--------|--------|---------|--------|--------|--------|
| | | | 1 | | 2 | | 2 | | 3+4 | | 3+4 | |
| PLDW 0,3t | M8 | 10 | 600 | 300 | 1.200 | 600 | 400 | 300 | 600 | 400 | 300 | 300 |
| PLDW 0,5t | M10 | 10 | 1.200 | 500 | 2.400 | 1.000 | 700 | 500 | 1.000 | 750 | 500 | 500 |
| PLDW 0,7t | M12 | 15 | 1.800 | 700 | 3.600 | 1.400 | 950 | 700 | 1.400 | 1.000 | 700 | 700 |
| PLDW 1t | M14 | 25 | 2.400 | 1.000 | 4.800 | 2.000 | 1.400 | 1.000 | 2.100 | 1.500 | 1.000 | 1.000 |
| PLDW 1,5t | M16 | 30 | 2.800 | 1.500 | 5.600 | 3.000 | 2.100 | 1.500 | 3.100 | 2.200 | 1.500 | 1.500 |
| PLDW 1,5t | M18 | 40 | 2.800 | 1.500 | 5.600 | 3.000 | 2.100 | 1.500 | 3.100 | 2.200 | 1.500 | 1.500 |
| PLDW 1,8t | M20 | 80 | 2.800 | 1.800 | 5.600 | 3.600 | 2.500 | 1.800 | 3.800 | 2.700 | 1.800 | 1.800 |
| PLDW 2,5t | M20 | 80 | 5.000 | 2.500 | 10.000 | 5.000 | 3.500 | 2.500 | 5.300 | 3.500 | 2.500 | 2.500 |
| PLDW 3,5t | M24 | 150 | 5.000 | 3.500 | 10.000 | 7.000 | 4.900 | 3.500 | 7.400 | 5.200 | 3.500 | 3.500 |
| PLDW 4t | M24 | 150 | 7.000 | 4.000 | 14.000 | 8.000 | 5.500 | 4.000 | 8.400 | 6.000 | 4.000 | 4.000 |
| PLDW 5,3t | M30 | 230 | 7.000 | 5.300 | 14.000 | 10.600 | 7.400 | 5.300 | 11.200 | 7.900 | 5.300 | 5.300 |
| PLDW 6,7t | M30 | 230 | 10.000 | 6.700 | 20.000 | 13.400 | 9.400 | 6.700 | 14.200 | 10.000 | 6.700 | 6.700 |
| PLDW 8t | M36 | 450 | 12.500 | 8.000 | 25.000 | 16.000 | 11.200 | 8.000 | 16.800 | 12.000 | 8.000 | 8.000 |
| PLDW 10t | M42 | 600 | 16.000 | 10.000 | 32.000 | 20.000 | 14.000 | 10.000 | 21.000 | 15.000 | 10.000 | 10.000 |
| PLDW 12t | M45 | 600 | 16.000 | 12.000 | 32.000 | 24.000 | 16.900 | 12.000 | 25.400 | 18.000 | 12.000 | 12.000 |
| PLDW M48 - 13t | M48 | 600 | 16.000 | 13.000 | 32.000 | 26.000 | 18.300 | 13.000 | 27.500 | 19.500 | 13.000 | 13.000 |
| PLDW M52 - 13t | M52 | 600 | 16.000 | 13.000 | 32.000 | 26.000 | 18.300 | 13.000 | 27.500 | 19.500 | 13.000 | 13.000 |
| PLDW 20t | M52 | 700 | 25.000 | 20.000 | 50.000 | 40.000 | 28.200 | 20.000 | 42.400 | 30.000 | 20.000 | 20.000 |
| PLDW 24t | M56 | 800 | 28.000 | 24.000 | 56.000 | 48.000 | 33.900 | 24.000 | 50.900 | 36.000 | 24.000 | 24.000 |
| PLDW 25t | M64 | 800 | 28.000 | 25.000 | 56.000 | 50.000 | 35.300 | 25.000 | 53.000 | 37.500 | 25.000 | 25.000 |
| PLDW 40t | M72 | 1200 | 60.000 | 40.000 | 120.000 | 80.000 | 56.500 | 40.000 | 84.800 | 60.000 | 40.000 | 40.000 |
| PLDW 45t | M80 | 1400 | 60.000 | 45.000 | 120.000 | 90.000 | 63.600 | 45.000 | 95.400 | 67.500 | 45.000 | 45.000 |
| PLDW M90-55t | M90 | 1500 | 60.000 | 55.000 | 120.000 | 110.000 | 77.700 | 55.000 | 116.600 | 82.500 | 55.000 | 55.000 |
| PLDW M100-55t | M100 | 1600 | 60.000 | 55.000 | 120.000 | 110.000 | 77.700 | 55.000 | 116.600 | 82.500 | 55.000 | 55.000 |

| Code | Thread [inch] | Torque [ft-lbs] | Working load limit (G) | | | | | | | | | |
|--------------|---------------|-----------------|------------------------|--------|---------|--------|--------|--------|--------|--------|--------|--------|
| | | | 1 | | 2 | | 2 | | 3+4 | | 3+4 | |
| PLDW U 3/8* | 3/8"-16 | 7,50 | 2.640 | 1.100 | 5.290 | 2.200 | 1.500 | 1.100 | 2.330 | 1.650 | 1.100 | 1.100 |
| PLDW U 1/2* | 1/2"-13 | 11 | 3.900 | 1.500 | 7.900 | 3.000 | 2.100 | 1.500 | 3.200 | 2.300 | 1.500 | 1.500 |
| PLDW U 5/8* | 5/8"-11 | 22 | 6.100 | 3.300 | 12.300 | 6.600 | 4.600 | 3.300 | 7.000 | 4.900 | 3.300 | 3.300 |
| PLDW U 3/4* | 3/4"-10 | 60 | 8.800 | 4.400 | 17.600 | 8.800 | 6.200 | 4.400 | 9.300 | 6.600 | 4.400 | 4.400 |
| PLDW U 1* | 1"-8 | 110 | 15.400 | 8.800 | 30.800 | 17.600 | 12.400 | 8.800 | 18.700 | 13.200 | 8.800 | 8.800 |
| PLDW U 1 1/4 | 1 1/4"-7 | 170 | 22.000 | 14.700 | 44.000 | 29.500 | 20.800 | 14.700 | 31.300 | 22.100 | 14.700 | 14.700 |
| PLDW U 1 1/2 | 1 1/2"-6 | 330 | 27.500 | 17.600 | 55.100 | 35.200 | 24.600 | 17.600 | 37.400 | 26.400 | 17.600 | 17.600 |
| PLDW U 1 3/4 | 1 3/4"-5 | 440 | 35.200 | 22.000 | 70.500 | 44.000 | 31.100 | 22.000 | 46.700 | 33.000 | 22.000 | 22.000 |
| PLDW U 2 | 2"-4,5 | 440 | 35.200 | 27.500 | 70.500 | 55.100 | 38.900 | 27.500 | 58.400 | 41.300 | 27.500 | 27.500 |
| PLDW U 2 1/2 | 2 1/2"-4 | 600 | 61.700 | 39.600 | 123.400 | 79.300 | 56.100 | 39.600 | 84.100 | 59.500 | 39.600 | 39.600 |

*Available as a standard stock item.

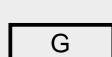
Note: The UNC option is available upon request. If you have any questions, please feel free to contact us.

Safety factor 4:1

| | | |
|--|---|--|
| <p>Straight pull 0°</p>  | <p>Lateral load direction „permitted“ (ring is aligned) 90°</p>  | <p>Lateral load direction not permitted (ring is not aligned)</p>  |
|  |  |  |
| <p>Higher working load limit for loading along the screw axis (column "0°" in the working load limit table)</p> | <p>Nominal working load limit for loading vertically to the screw axis (column "90°" in the working load limit table)</p> | <p>Application not permitted due to unstable conditions. The ring could turn suddenly while under load - high risk for load and/or persons!</p> |

| Code | Thread [mm] | WLL [kg] | a [mm] | b [mm] | c [mm] | d [mm] | e [mm] | f [mm] | n [mm] | n max [mm] | ⊘ [mm] | Weight [kg/unit] |
|----------------|-------------|----------|--------|--------|--------|--------|--------|--------|--------|------------|--------|------------------|
| PLDW 0,3t | M8 | 300 | 30 | 56 | 13 | 38 | 110 | 38 | 20 | 100 | 34 | 0,45 |
| PLDW 0,5t | M10 | 500 | 30 | 56 | 13 | 38 | 110 | 38 | 20 | 180 | 34 | 0,45 |
| PLDW 0,7t | M12 | 700 | 35 | 61 | 13 | 48 | 115 | 38 | 22 | 200 | 34 | 0,48 |
| PLDW 1t | M14 | 1.000 | 35 | 61 | 13 | 48 | 115 | 38 | 22 | 200 | 34 | 0,49 |
| PLDW 1,5t | M16 | 1.500 | 35 | 61 | 13 | 48 | 115 | 38 | 33 | 250 | 34 | 0,51 |
| PLDW 1,5t | M18 | 1.500 | 35 | 61 | 13 | 48 | 115 | 38 | 30 | 250 | 34 | 0,51 |
| PLDW 1,8t | M20 | 1.800 | 35 | 61 | 13 | 48 | 115 | 38 | 30 | 250 | 34 | 0,50 |
| PLDW 2,5t | M20 | 2.500 | 35 | 67 | 16 | 55 | 147 | 55 | 33 | 250 | 46 | 1,10 |
| PLDW 3,5t | M24 | 3.500 | 35 | 67 | 16 | 55 | 147 | 55 | 30 | 250 | 46 | 1,10 |
| PLDW 4t | M24 | 4.000 | 40 | 74 | 17 | 66 | 165 | 63 | 40 | 300 | 50 | 1,50 |
| PLDW 5,3t | M30 | 5.300 | 40 | 74 | 17 | 66 | 165 | 63 | 35 | 300 | 50 | 1,50 |
| PLDW 6,7t | M30 | 6.700 | 50 | 96 | 23 | 70 | 185 | 72 | 40 | 300 | 60 | 2,60 |
| PLDW 8t | M36 | 8.000 | 50 | 96 | 23 | 91 | 233 | 92 | 55 | 300 | 75 | 4,30 |
| PLDW 10t | M42 | 10.000 | 65 | 119 | 27 | 91 | 237 | 92 | 60 | 300 | 75 | 5,10 |
| PLDW 12t | M45 | 12.000 | 65 | 119 | 27 | 91 | 237 | 92 | 68 | 300 | 75 | 5,20 |
| PLDW M48 - 13t | M48 | 13.000 | 65 | 119 | 27 | 116 | 262 | 92 | 68 | 300 | 75 | 5,40 |
| PLDW M52 - 13t | M52 | 13.000 | 65 | 119 | 27 | 116 | 262 | 92 | 75 | 300 | 75 | 5,40 |
| PLDW 20t | M52 | 20.000 | 70 | 136 | 33 | 105 | 292 | 110 | 78 | 300 | 95 | 10,20 |
| PLDW 24t | M56 | 24.000 | 70 | 136 | 33 | 105 | 292 | 110 | 84 | 300 | 95 | 10,20 |
| PLDW 25t | M64 | 25.000 | 70 | 136 | 33 | 105 | 292 | 110 | 96 | 300 | 95 | 11,00 |
| PLDW 40t | M72 | 40.000 | 90 | 180 | 45 | 130 | 386 | 170 | 110 | 500 | 145 | 29,00 |
| PLDW 45t | M80 | 45.000 | 90 | 180 | 45 | 130 | 386 | 170 | 120 | 500 | 145 | 30,00 |
| PLDW M90-55t | M90 | 55.000 | 90 | 180 | 45 | 130 | 386 | 170 | 135 | 500 | 145 | 32,00 |
| PLDW M100-55t | M100 | 55.000 | 90 | 180 | 45 | 130 | 386 | 170 | 150 | 500 | 145 | 35,00 |

| Code | Thread [inch] | WLL [lbs] | a [inch] | b [inch] | c [inch] | d [inch] | e [inch] | f [inch] | n [inch] | n max [inch] | ⊘ [inch] | Weight [lbs/pcs.] |
|--------------|---------------|-----------|----------|----------|----------|----------|----------|----------|----------|--------------|----------|-------------------|
| PLDW U 3/8* | 3/8"-16 | 1.100 | 1,18 | 2,20 | 0,51 | 1,50 | 4,33 | 1,50 | 0,59 | - | 1,34 | 1,00 |
| PLDW U 1/2* | 1/2"-13 | 1.500 | 1,38 | 2,40 | 0,51 | 1,89 | 4,53 | 1,50 | 0,79 | - | 1,34 | 1,06 |
| PLDW U 5/8* | 5/8"-11 | 3.300 | 1,38 | 2,40 | 0,51 | 1,89 | 4,53 | 1,50 | 0,98 | - | 1,34 | 1,10 |
| PLDW U 3/4* | 3/4"-10 | 4.400 | 1,38 | 2,64 | 0,63 | 2,17 | 5,79 | 2,17 | 1,18 | - | 1,81 | 2,43 |
| PLDW U 1* | 1"-8 | 8.800 | 1,57 | 2,91 | 0,67 | 2,60 | 6,50 | 2,48 | 1,57 | - | 1,97 | 3,30 |
| PLDW U 1 1/4 | 1 1/4"-7 | 14.700 | 1,97 | 3,78 | 0,91 | 2,76 | 7,28 | 2,83 | 1,77 | - | 2,36 | 5,70 |
| PLDW U 1 1/2 | 1 1/2"-6 | 17.600 | 1,97 | 3,78 | 0,91 | 3,58 | 9,17 | 3,62 | 2,17 | - | 2,95 | 9,50 |
| PLDW U 1 3/4 | 1 3/4"-5 | 22.000 | 2,56 | 4,69 | 1,06 | 3,58 | 9,33 | 3,62 | 2,36 | - | 2,95 | 11,20 |
| PLDW U 2 | 2"-4,5 | 27.500 | 2,56 | 4,69 | 1,06 | 4,57 | 10,31 | 3,62 | 2,68 | - | 2,95 | 11,90 |
| PLDW U 2 1/2 | 2 1/2"-4 | 39.600 | 2,76 | 5,35 | 1,30 | 4,13 | 11,50 | 4,33 | 3,78 | - | 3,74 | 22,40 |

*Available as a standard stock item.

Note: The UNC option is available upon request. If you have any questions, please feel free to contact us.

Safety factor 4:1

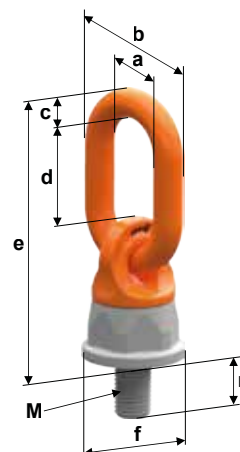

pewag PLZW-FIX-SP zeta

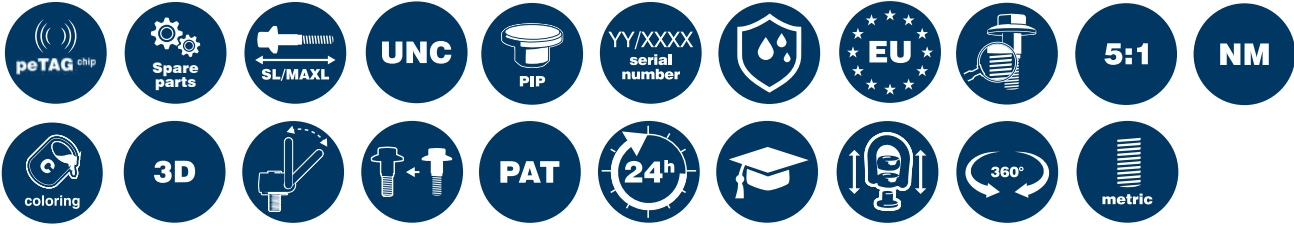

Thanks to its innovative design, the pewag winner pro points lifting point PLZW-FIX-SP may be assembled and disassembled without the use of tools (applies up to thread size M24). The PLZW-FIX-SP therefore makes it possible to directly attach closed lifting equipment such as eye sling hooks or rope loops, without having to use additional shackles.

The latest addition to the pewag lifting point portfolio comes with a five-fold safety factor against breakage, is rotatable by 360° and may be loaded in all directions. The individual serial number and the batch number make it possible to clearly identify the lifting point at all times. The PLZW-FIX-SP protects the surface of the load from damage thanks to an integrated sleeve. The screw is 100% crack-tested, comes with a chromate VI-free protection against corrosion and is marked with the working load limit, thread size and torque. The PLZW-FIX-SP is mounted in the desired position using a tool.

Optionally also available with peTAG (NFC chip) or PIP (colour marking).

The PLZW FIX SP is available in two options:

The standard option, PLZW FIX SP, is non-dismountable but includes a spring that ensures the ring stays in its position. It is identified by a grey sleeve (Fig. 1).

The special option, PLZW, is easily dismountable and designed for quick and effortless disassembly into its individual parts. This special feature enables the direct assembly of various fittings (such as roundslings, webbing slings, wire rope eyes, master links, and eye-type hooks). It is distinguished by a golden-colored sleeve (Fig. 2).



Figure 1: PLZW FIX SP (not dismountable, with spring)

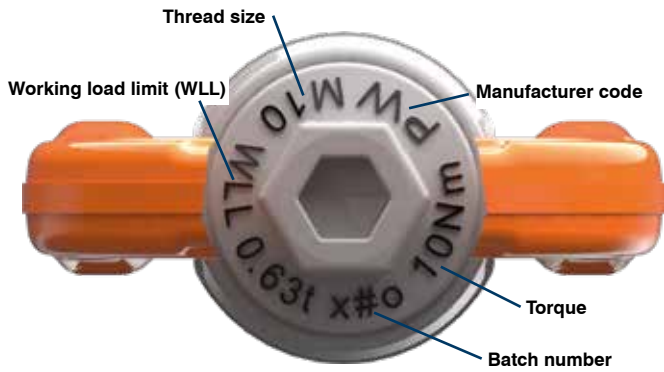

Marking on the screw

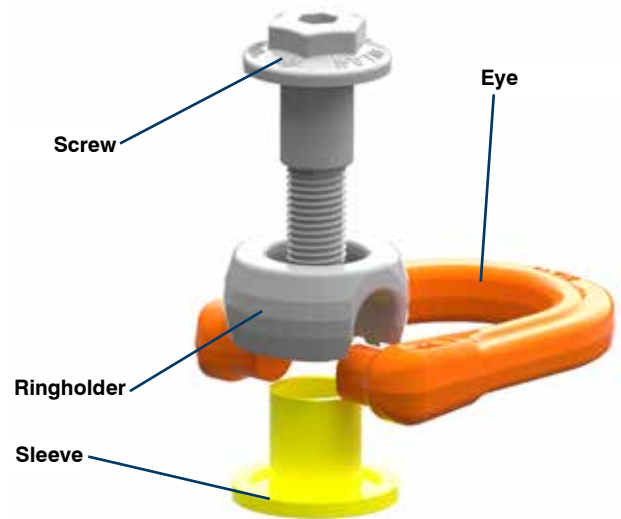

Figure 2: PLZW lifting point (dismountable, indicated by a golden sleeve)



Application examples of the dismountable Version of the PLZW



The PLZW-FIX-SP replaces the PLBW. However, the PLBW and its spare parts remain available upon request.

pewag PLZW zeta

Method of lifting
Number of legs
Angle of inclination

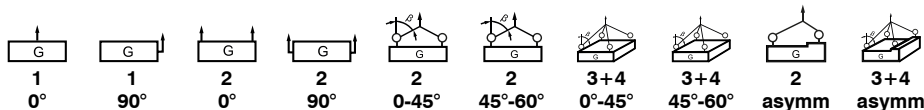

| Code | Thread [mm] | Torque [Nm] | Working load limit (G) | | | | | | | | | | | | | | | | | |
|--------------------|-------------|-------------|------------------------|--------|-----------|--------|-----------|--------|------------|--------|--------------|--------|---------------|--|----------------|--|-----------------|--|--------|--|
| | | | 1 leg 0° | | 1 leg 90° | | 2 legs 0° | | 2 legs 90° | | 2 legs 0-45° | | 2 legs 45-60° | | 3+4 legs 0-45° | | 3+4 legs 45-60° | | 2 asym | |
| PLZW-FIX-SP 0,4t* | M8 | 10 | 800 | 400 | 1.600 | 800 | 560 | 400 | 840 | 600 | 400 | 400 | | | | | | | | |
| PLZW-FIX-SP 0,63t* | M10 | 10 | 1.100 | 630 | 2.200 | 1.260 | 890 | 630 | 1.330 | 940 | 630 | 630 | | | | | | | | |
| PLZW-FIX-SP 0,95t* | M12 | 15 | 1.100 | 950 | 2.200 | 1.900 | 1.340 | 950 | 2.010 | 1.420 | 950 | 950 | | | | | | | | |
| PLZW-FIX-SP 1,3t* | M14 | 30 | 2.900 | 1.300 | 5.800 | 2.600 | 1.830 | 1.300 | 2.750 | 1.950 | 1.300 | 1.300 | | | | | | | | |
| PLZW-FIX-SP 1,8t* | M16 | 50 | 2.900 | 1.800 | 5.800 | 3.600 | 2.540 | 1.800 | 3.810 | 2.700 | 1.800 | 1.800 | | | | | | | | |
| PLZW-FIX-SP 2,2t* | M18 | 70 | 2.900 | 2.200 | 5.800 | 4.400 | 3.110 | 2.200 | 4.660 | 3.300 | 2.200 | 2.200 | | | | | | | | |
| PLZW-FIX-SP 2,5t* | M20 | 100 | 2.900 | 2.500 | 5.800 | 5.000 | 3.530 | 2.500 | 5.300 | 3.750 | 2.500 | 2.500 | | | | | | | | |
| PLZW-FIX-SP 3,7t* | M22 | 120 | 6.500 | 3.700 | 13.000 | 7.400 | 5.230 | 3.700 | 7.840 | 5.550 | 3.700 | 3.700 | | | | | | | | |
| PLZW-FIX-SP 4t* | M24 | 160 | 6.500 | 4.000 | 13.000 | 8.000 | 5.650 | 4.000 | 8.480 | 6.000 | 4.000 | 4.000 | | | | | | | | |
| PLZW-FIX-SP 5,4t | M27 | 200 | 6.500 | 5.400 | 13.000 | 10.800 | 7.600 | 5.400 | 11.400 | 8.100 | 5.400 | 5.400 | | | | | | | | |
| PLZW-FIX-SP 6,3t | M30 | 250 | 6.500 | 6.300 | 13.000 | 12.600 | 8.900 | 6.300 | 13.300 | 9.400 | 6.300 | 6.300 | | | | | | | | |
| PLZW-FIX-SP 8t | M33 | 270 | 15.000 | 8.000 | 30.000 | 16.000 | 11.300 | 8.000 | 16.900 | 12.000 | 8.000 | 8.000 | | | | | | | | |
| PLZW-FIX-SP 10t | M36 | 320 | 15.000 | 10.000 | 30.000 | 20.000 | 14.100 | 10.000 | 21.200 | 15.000 | 10.000 | 10.000 | | | | | | | | |
| PLZW-FIX-SP 13t | M42 | 400 | 15.000 | 13.000 | 30.000 | 26.000 | 18.300 | 13.000 | 27.500 | 19.500 | 13.000 | 13.000 | | | | | | | | |
| PLZW-FIX-SP 15t | M48 | 600 | 15.000 | 15.000 | 30.000 | 30.000 | 21.200 | 15.000 | 31.800 | 22.500 | 15.000 | 15.000 | | | | | | | | |

| Code | Safety Factor | Thread [inch] | Torque [ft-lbs] | Working load limit (G) | | | | | | | | | | | | | | | | | |
|---------------------|---------------|---------------|-----------------|------------------------|--------|-----------|--------|-----------|--------|------------|--------|--------------|--------|---------------|--|----------------|--|-----------------|--|--|--|
| | | | | 1 leg 0° | | 1 leg 90° | | 2 legs 0° | | 2 legs 90° | | 2 legs 0-45° | | 2 legs 45-60° | | 3+4 legs 0-45° | | 3+4 legs 45-60° | | | |
| PLZW-FIX-SP U5/16 | 5:1 | 5/16"-18 | 5 | 1.100 | 660 | 2.200 | 1.320 | 930 | 660 | 1.400 | 990 | 660 | 660 | | | | | | | | |
| PLZW-FIX-SP U3/8 | 5:1 | 3/8"-16 | 8 | 2.200 | 1.300 | 4.400 | 2.600 | 1.830 | 1.300 | 2.750 | 1.950 | 1.300 | 1.300 | | | | | | | | |
| PLZW-FIX-SP U1/2 | 5:1 | 1/2"-13 | 11 | 2.400 | 2.200 | 4.800 | 4.400 | 3.100 | 2.200 | 4.600 | 3.300 | 2.200 | 2.200 | | | | | | | | |
| PLZW-FIX-SP U9/16 | 5:1 | 9/16"-12 | 22 | 4.400 | 3.000 | 8.800 | 6.000 | 4.200 | 3.000 | 6.300 | 4.500 | 3.000 | 3.000 | | | | | | | | |
| PLZW-FIX-SP U 5/8 | 5:1 | 5/8"-11 | 37 | 5.500 | 3.500 | 11.000 | 7.000 | 4.900 | 3.500 | 7.400 | 5.200 | 3.500 | 3.500 | | | | | | | | |
| PLZW-FIX-SP U 3/4 | 4:1 | 3/4"-10 | 74 | 6.600 | 5.500 | 13.200 | 11.000 | 7.700 | 5.500 | 11.600 | 8.200 | 5.500 | 5.500 | | | | | | | | |
| PLZW-FIX-SP U 7/8 | 4:1 | 7/8"-9 | 118 | 12.000 | 8.800 | 24.000 | 17.600 | 12.400 | 8.800 | 18.600 | 13.200 | 8.800 | 8.800 | | | | | | | | |
| PLZW-FIX-SP U 1 | 4:1 | 1"-8 | 148 | 13.000 | 11.000 | 26.000 | 22.000 | 15.500 | 11.000 | 23.300 | 16.500 | 11.000 | 11.000 | | | | | | | | |
| PLZW-FIX-SP U 1 1/8 | 4:1 | 1 1/8"-7 | 185 | 14.300 | 13.500 | 28.600 | 27.000 | 19.000 | 13.500 | 28.600 | 20.200 | 13.500 | 13.500 | | | | | | | | |
| PLZW-FIX-SP U 1 1/4 | 4:1 | 1 1/4"-7 | 200 | 20.000 | 17.500 | 40.000 | 35.000 | 24.700 | 17.500 | 37.100 | 26.200 | 17.500 | 17.500 | | | | | | | | |
| PLZW-FIX-SP U 1 3/8 | 4:1 | 1 3/8"-6 | 236 | 24.000 | 22.000 | 48.000 | 44.000 | 31.100 | 22.000 | 46.600 | 33.000 | 22.000 | 22.000 | | | | | | | | |
| PLZW-FIX-SP U 1 1/2 | 4:1 | 1 1/2"-6 | 295 | 25.000 | 24.000 | 50.000 | 48.000 | 33.900 | 24.000 | 50.900 | 36.000 | 24.000 | 24.000 | | | | | | | | |

*Also available in the easily dismantlable version as PLZW.

Note: The PLZW replaces the PLBW. However, the PLBW and its spare parts remain available upon request.

| Straight pull 0° | Lateral load direction permitted (ring is aligned) 90° | Lateral load direction not permitted (ring is not aligned) |
|--|--|--|
| | | |
| Higher working load limit for loading along the screw axis (column „0°“ in the working load limit table) | Nominal working load limit for loading vertically to the screw axis (column „90°“ in the working load limit table) | Application not permitted due to unstable conditions. The ring could turn suddenly while under load - high risk for load and/or persons! |

| Code | Thread [mm] | WLL S ¹⁾ =5:1 [kg] | WLL S ¹⁾ =4:1 [kg] | a [mm] | b [mm] | c [mm] | d [mm] | e [mm] | f [mm] | h [mm] | n [mm] | n max [mm] | ⊘ [mm] | ⊘ [mm] | Weight [kg/ unit] |
|--------------------|----------------|-------------------------------------|-------------------------------------|-----------|-----------|-----------|-----------|-----------|-----------|-----------|-----------|---------------|-----------|-----------|-------------------------|
| PLZW-FIX-SP 0,4t* | M8 | 400 | 500 | 40 | 64 | 14 | 34 | 77 | 30 | 29 | 12 | 80 | 8 | 15 | 0,30 |
| PLZW-FIX-SP 0,63t* | M10 | 630 | 780 | 40 | 64 | 14 | 34 | 77 | 30 | 29 | 15 | 100 | 8 | 15 | 0,30 |
| PLZW-FIX-SP 0,95t* | M12 | 950 | 1.180 | 40 | 64 | 14 | 34 | 77 | 30 | 29 | 18 | 180 | 8 | 15 | 0,31 |
| PLZW-FIX-SP 1,3t* | M14 | 1.300 | 1.600 | 50 | 83 | 19 | 50 | 112 | 45 | 43 | 21 | 220 | 10 | 24 | 0,89 |
| PLZW-FIX-SP 1,8t* | M16 | 1.800 | 2.250 | 50 | 83 | 19 | 50 | 112 | 45 | 43 | 24 | 260 | 10 | 24 | 0,90 |
| PLZW-FIX-SP 2,2t* | M18 | 2.200 | 2.750 | 50 | 83 | 19 | 50 | 112 | 45 | 43 | 27 | 300 | 10 | 24 | 0,91 |
| PLZW-FIX-SP 2,5t* | M20 | 2.500 | 3.100 | 50 | 83 | 19 | 50 | 112 | 45 | 43 | 30 | 330 | 10 | 24 | 0,95 |
| PLZW-FIX-SP 3,7t* | M22 | 3.700 | 4.600 | 70 | 121 | 28 | 69 | 161 | 68 | 64 | 33 | 355 | 14 | 36 | 2,80 |
| PLZW-FIX-SP 4t* | M24 | 4.000 | 5.000 | 70 | 121 | 28 | 69 | 161 | 68 | 64 | 36 | 355 | 14 | 36 | 2,80 |
| PLZW-FIX-SP 5,4t | M27 | 5.400 | 6.700 | 70 | 121 | 28 | 69 | 161 | 68 | 64 | 40 | 355 | 14 | 36 | 2,90 |
| PLZW-FIX-SP 6,3t | M30 | 6.300 | 7.800 | 70 | 121 | 28 | 69 | 161 | 68 | 64 | 45 | 355 | 14 | 36 | 3,00 |
| PLZW-FIX-SP 8t | M33 | 8.000 | 10.000 | 110 | 183 | 38 | 114 | 259 | 108 | 106 | 54 | 328 | 19 | 55 | 10,6 |
| PLZW-FIX-SP 10t | M36 | 10.000 | 12500 | 110 | 183 | 38 | 114 | 259 | 108 | 106 | 59 | 328 | 19 | 55 | 10,8 |
| PLZW-FIX-SP 13t | M42 | 13.000 | 16200 | 110 | 183 | 38 | 114 | 259 | 108 | 106 | 69 | 328 | 19 | 55 | 11,1 |
| PLZW-FIX-SP 15t | M48 | 15.000 | 18700 | 110 | 183 | 38 | 114 | 259 | 108 | 106 | 74 | 328 | 19 | 55 | 11,2 |

¹⁾ S= Safety Factor

| Code | Safety Fac- tor | Thread [inch] | WLL [lbs] | a [inch] | b [inch] | c [inch] | d [inch] | e [inch] | f [inch] | h [inch] | n [inch] | n max [inch] | ⊘ [inch] | ⊘ [inch] | Weight [lbs/pc.] |
|---------------------|-----------------------|------------------|--------------|-------------|-------------|-------------|-------------|-------------|-------------|-------------|-------------|-----------------|-------------|-------------|---------------------|
| PLZW-FIX-SP U5/16 | 5:1 | 5/16"-18 | 660 | 1,57 | 2,52 | 0,55 | 1,34 | 3,03 | 1,18 | 1,14 | 0,51 | - | 5/16" | 5/8" | 0,66 |
| PLZW-FIX-SP U3/8 | 5:1 | 3/8"-16 | 1.300 | 1,57 | 2,52 | 0,55 | 1,34 | 3,03 | 1,18 | 1,14 | 0,59 | - | 5/16" | 5/8" | 0,66 |
| PLZW-FIX-SP U1/2 | 5:1 | 1/2"-13 | 2.200 | 1,57 | 2,52 | 0,55 | 1,34 | 3,03 | 1,18 | 1,14 | 0,67 | - | 5/16" | 5/8" | 0,66 |
| PLZW-FIX-SP U 9/16 | 5:1 | 9/16"-12 | 3.000 | 1,97 | 3,27 | 0,75 | 1,97 | 4,41 | 1,77 | 1,69 | 0,87 | - | 5/16" | 1" | 2,00 |
| PLZW-FIX-SP U 5/8 | 5:1 | 5/8"-11 | 3.500 | 1,97 | 3,27 | 0,75 | 1,97 | 4,41 | 1,77 | 1,69 | 0,94 | - | 5/16" | 1" | 2,00 |
| PLZW-FIX-SP U 3/4 | 4:1 | 3/4"-10 | 5.500 | 1,97 | 3,27 | 0,75 | 1,97 | 4,41 | 1,77 | 1,69 | 1,18 | - | 5/16" | 1" | 2,10 |
| PLZW-FIX-SP U 7/8 | 4:1 | 7/8"-9 | 8.800 | 2,76 | 4,76 | 1,10 | 2,72 | 6,34 | 2,68 | 2,52 | 1,42 | - | 9/16" | 1 3/8" | 6,10 |
| PLZW-FIX-SP U 1 | 4:1 | 1"-8 | 11.000 | 2,76 | 4,76 | 1,10 | 2,72 | 6,34 | 2,68 | 2,52 | 1,57 | - | 9/16" | 1 3/8" | 6,30 |
| PLZW-FIX-SP U 1 1/8 | 4:1 | 1 1/8"-7 | 13.500 | 2,76 | 4,76 | 1,10 | 2,72 | 6,34 | 2,68 | 2,52 | 1,77 | - | 9/16" | 1 3/8" | 6,30 |
| PLZW-FIX-SP U1 1/4 | 4:1 | 1 1/4"-7 | 17.500 | 4,33 | 7,20 | 1,50 | 4,49 | 10,20 | 4,25 | 4,17 | 2,13 | - | 3/4" | 2 3/16" | 23,6 |
| PLZW-FIX-SP U1 3/8 | 4:1 | 1 3/8"-6 | 22.000 | 4,33 | 7,20 | 1,50 | 4,49 | 10,20 | 4,25 | 4,17 | 2,32 | - | 3/4" | 2 3/16" | 23,6 |
| PLZW-FIX-SP U1 1/2 | 4:1 | 1 1/2"-6 | 24.000 | 4,33 | 7,20 | 1,50 | 4,49 | 10,20 | 4,25 | 4,17 | 2,72 | - | 3/4" | 2 3/16" | 24,3 |

*Also available in the easily dismantlable version as PLZW.

Note: The PLZW replaces the PLBW. However, the PLBW and its spare parts remain available upon request.

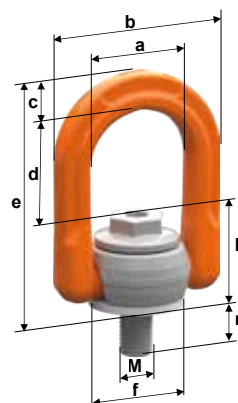

pewag PLZW-rapid



The PLZW-rapid is a lifting point from the pewag winner pro points family, distinguished by its innovative features. It allows for quick and easy assembly: simply press the button to unlock the threaded plates, insert the lifting point into the threaded hole, release the button, and tighten the screw by hand. The locking indicator must then be checked to ensure the green ring is visible, confirming the lifting point is ready for use.

Designed for maximum flexibility, the PLZW-rapid is 360° rotatable, allowing for adjustment in the direction of the load, and the ring can be folded 180° for added versatility. The screw is made of rust-resistant stainless steel, while the sleeve protects the contact surface of the load. Each unit features an individual serial number for traceability and offers a five-fold safety factor against breakage. It operates reliably in temperatures from -20°C to 200°C without any reduction in performance.

Benefits of the PLZW-rapid lifting point:

- Time saving thanks to click and go function
- Tool-free assembly/disassembly
- Optionally also available with peTAG (NFC chip) or PIP (colour marking)



Figure 1: PLZW FIX SP (not dismountable, with spring)



Press and hold the button (left) to unlock the threaded plates for easy insertion. Tighten the screw by hand (right) until the green marking is visible.

Green Marking on the screw

Method of lifting
Number of legs
Angle of inclination

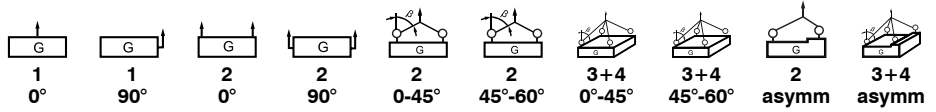

| Code | Thread [mm] | Torque [Nm] | Working load limit (G) [kg] | | | | | | | | | |
|-------------|-------------|-------------|-----------------------------|-------|-------|-------|-------|-------|-------|-------|-------|-------|
| | | | 1 | 1 | 2 | 2 | 2 | 2 | 3+4 | 3+4 | 2 | 3+4 |
| PLZW-R 0.4t | M10 | 20 | 400 | 400 | 800 | 800 | 560 | 400 | 840 | 600 | 400 | 400 |
| PLZW-R 0.5t | M12 | 50 | 500 | 500 | 1.000 | 1.000 | 700 | 500 | 1.060 | 750 | 500 | 500 |
| PLZW-R 1.1t | M16 | 70 | 1.100 | 1.100 | 2.200 | 2.200 | 1.550 | 1.100 | 2.330 | 1.650 | 1.100 | 1.100 |

Safety factor 5:1

| Code | Thread [mm] | Load capacity [kg] | a [mm] | b [mm] | c [mm] | d [mm] | e [mm] | f [mm] | h [mm] | n [mm] | Ø [mm] | Weight [kg/pc.] |
|-------------|-------------|--------------------|--------|--------|--------|--------|--------|--------|--------|--------|--------|-----------------|
| PLZW-R 0.4t | M10 | 400 | 40 | 64 | 14 | 33 | 77 | 30 | 30 | 20 | 19 | 0,30 |
| PLZW-R 0.5t | M12 | 500 | 40 | 64 | 14 | 33 | 77 | 30 | 30 | 23 | 19 | 0,30 |
| PLZW-R 1.1t | M16 | 1.100 | 50 | 83 | 19 | 53 | 112 | 45 | 41 | 24 | 32 | 0,85 |



| Straight pull 0° | Lateral load direction permitted (ring is aligned) 90° | Lateral load direction not permitted (ring is not aligned) |
|---|--|--|
| | | |
| Nominal working load limit for loading along the screw axis (column „0°“ in the working load limit table) | Nominal working load limit for loading vertically to the screw axis (column „90°“ in the working load limit table) | Application not permitted due to unstable conditions. The ring could turn suddenly while under load - high risk for load and/or persons! |

pewag PLZW-DW DW15



The PLZW-DW DW15 lifting point, specifically designed for concrete and steel structures, enables the efficient and safe transportation of concrete elements as well as steel constructions after proper installation. Once secured, the lifting point can be rotated 360°, while the load bracket can be folded 180° for added flexibility.

The PLZW-DW DW15 is attached to the anchor rod and features an integrated clamping mechanism that prevents unintentional loosening caused by vibrations.

It has a safety factor of 2.5:1, ensuring high reliability and safety under demanding load conditions.

Optionally also available with peTAG (NFC chip) or PIP (colour marking)

Permitted usage

For working load limits in the permitted directions of pull, please refer to the working load limit table.

Non-permitted usage

During assembly, ensure that improper loading does not arise due to any of the following factors:

- Direction of pull is obstructed
- Direction of pull is not within the indicated area
- Loading ring rests against edges or surfaces



Improper loading as loading ring rests against edges or surfaces

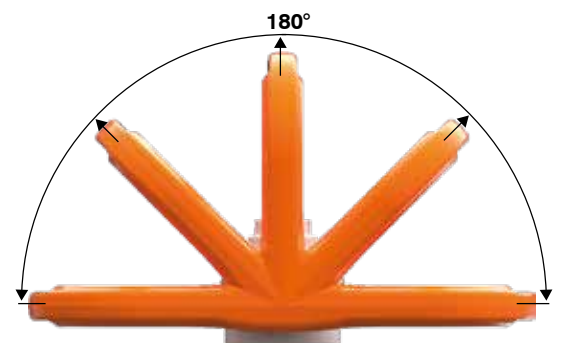

Permissible load directions

Method of lifting
Number of legs
Angle of inclination

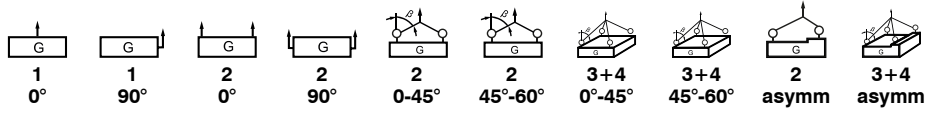

| Code | Thread [mm] | Torque [Nm] | Load capacity [kg] | | | | | | | | | |
|--------------|-------------|-------------|--------------------|-------|-------|-------|-------|-------|-------|-------|-------|-------|
| PLZW-DW DW15 | DW15 | 150 | 3.600 | 3.600 | 7.200 | 7.200 | 5.090 | 3.600 | 7.630 | 5.400 | 3.600 | 3.600 |

Tabelle 1

| Code | Thread | Load capacity | a [mm] | b [mm] | c [mm] | d [mm] | e [mm] | f [mm] | h [mm] | ⌀ [mm] | Weight [kg/pc.] |
|--------------|--------|---------------|--------|--------|--------|--------|--------|--------|--------|--------|-----------------|
| PLZW-DW DW15 | DW 15 | 3600 | 50 | 83 | 19 | 45 | 112 | 45 | 50 | 27 | 0,85 |



| Straight pull 0° | | Lateral load direction permitted (ring is aligned) 90° | | Lateral load direction not permitted (ring is not aligned) |
|---|--|--|--|--|
| | | | | |
| Nominal working load limit for loading along the screw axis (column „0°“ in the working load limit table) | | Nominal working load limit for loading vertically to the screw axis (column „90°“ in the working load limit table) | | Application not permitted due to unstable conditions. The ring could turn suddenly while under load - high risk for load and/or persons! |

pewag PLOW omega

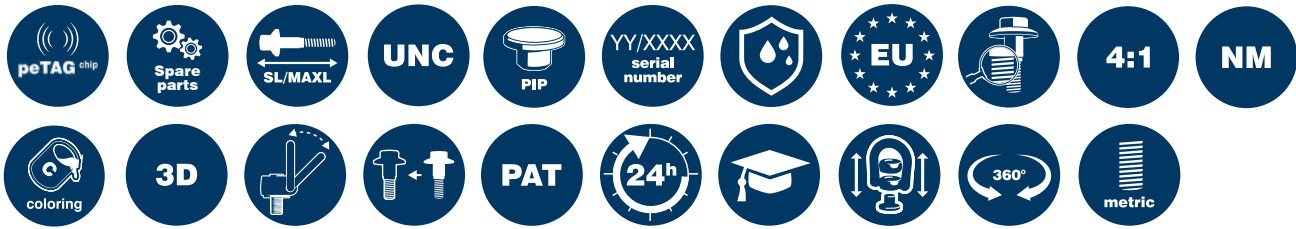

The PLOW is equipped with a ball bearing, allowing it to rotate smoothly even under load. Its patented design ensures innovative features and reliable performance. Assembly and disassembly can be carried out without the need for tools, making it quick and easy to handle. The ring is rotatable 360°, providing full adjustability in the load direction, and can be folded 180° for added flexibility.

A 100% crack-tested, corrosion-protected screw guarantees maximum safety and durability. The integrated sleeve protects the contact surface of the load, ensuring minimal wear and tear. Each unit comes with a unique serial number for traceability. The product offers four times the safety against breakage, meeting the highest safety standards.

The operating temperature range is from -20°C to 200°C without any reduction in the Working Load Limit (WLL). Additionally, the product is stamped with the required tightening torque, ensuring proper and secure installation.

Optionally also available with peTAG (NFC chip) or PIP (colour marking).

The PLOW is based on a patented system that allows for tool-free assembly and disassembly. The anchorage point is therefore easy to remove after usage. For detailed information on functionalities, please refer to the operating manual.

Additional benefits of the PLOW omega lifting point:

- Available in special lengths.
- Closed slings can be pre-assembled on request



Permitted usage

For working load limits in the permitted directions of pull, please refer to the working load limit table.

Non-permitted usage

During assembly, ensure that improper loading does not arise due to any of the following factors:

- Direction of pull is obstructed
- Direction of pull is not within the indicated area
- Loading ring rests against edges or surfaces



Non-permitted usage

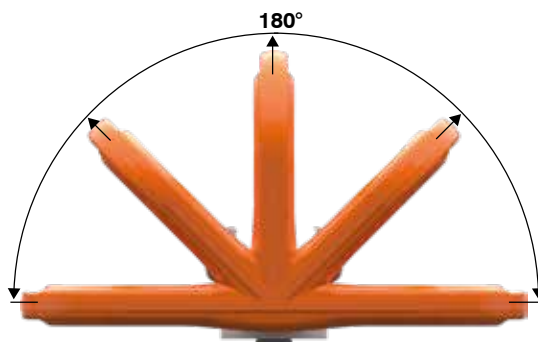

Permitted directions of load that occur during correct use.



PLOW rotatable



PLOW dis-/assembly



The integrated ball bearing allows the PLOW to rotate smoothly even under load.

Method of lifting
Number of legs
Angle of inclination

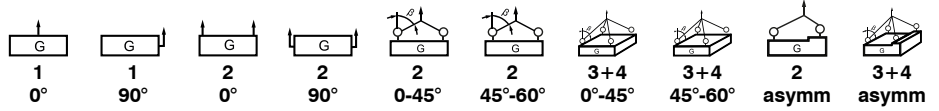

| Code | Thread [mm] | Torque [Nm] | Working load limit (G) [kg] | | | | | | | | | |
|----------|-------------|-------------|-----------------------------|-------|--------|-------|-------|-------|-------|-------|-------|-------|
| PLOW M8 | M8 | 10 | 1.000 | 400 | 2.000 | 800 | 560 | 400 | 840 | 600 | 400 | 400 |
| PLOW M10 | M10 | 15 | 1.400 | 800 | 2.800 | 1.600 | 1.130 | 800 | 1.690 | 1.200 | 800 | 800 |
| PLOW M12 | M12 | 20 | 1.400 | 1.200 | 2.800 | 2.400 | 1.690 | 1.200 | 2.540 | 1.800 | 1.200 | 1.200 |
| PLOW M16 | M16 | 50 | 3.200 | 2.000 | 6.400 | 4.000 | 2.800 | 2.000 | 4.200 | 3.000 | 2.000 | 2.000 |
| PLOW M20 | M20 | 100 | 6.500 | 3.400 | 13.000 | 6.800 | 4.800 | 3.400 | 7.200 | 5.100 | 3.400 | 3.400 |
| PLOW M24 | M24 | 150 | 6.500 | 4.700 | 13.000 | 9.400 | 6.600 | 4.700 | 9.900 | 7.000 | 4.700 | 4.700 |

Safety factor 4:1

| Code | Thread [mm] | WLL [kg] | a [mm] | b [mm] | c [mm] | d [mm] | e [mm] | f [mm] | h [mm] | n [mm] | n max [mm] | ⌀ [mm] | Weight [kg/unit] |
|----------|-------------|----------|--------|--------|--------|--------|--------|--------|--------|--------|------------|--------|------------------|
| PLOW M8 | M8 | 400 | 40 | 65 | 15 | 34 | 88 | 34 | 34 | 12 | 80 | 8 | 0,44 |
| PLOW M10 | M10 | 800 | 40 | 65 | 15 | 34 | 88 | 34 | 34 | 15 | 100 | 8 | 0,45 |
| PLOW M12 | M12 | 1.200 | 40 | 65 | 15 | 34 | 88 | 34 | 34 | 18 | 140 | 8 | 0,45 |
| PLOW M16 | M16 | 2.000 | 50 | 83 | 19 | 41 | 112 | 42 | 45 | 24 | 250 | 10 | 0,95 |
| PLOW M20 | M20 | 3.400 | 70 | 121 | 28 | 53 | 161 | 67 | 67 | 30 | 250 | 14 | 3,0 |
| PLOW M24 | M24 | 4.700 | 70 | 121 | 28 | 53 | 161 | 67 | 67 | 36 | 300 | 14 | 3,0 |



Straight pull 0°



Lateral load direction permitted (ring is aligned) 90°

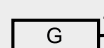

Lateral load direction not permitted (ring is not aligned)

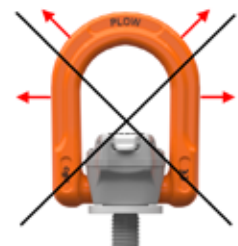

Higher working load limit for loading along the screw axis (column „0°“ in the working load limit table)

Nominal working load limit for loading vertically to the screw axis (column „90°“ in the working load limit table)

Application not permitted due to unstable conditions. The ring could turn suddenly while under load - high risk for load and/or persons!



pewag pro points

As individual as your needs.



pewag PLTW theta



The screwable PLTW is perfect for mounting machine parts or vehicle bodies, as well as for use as a lifting or load-securing device. Please consider the different safety factors, specifically the WLL for lifting and the LC for use as a tie-down device. The welded ring is flexible, and the bracket is drop-forged. Equipped with two high-quality, crack-tested screws.

Permitted usage

Please refer to the working load limit as stated in the inspection certificate and/or the working load limit table to ensure maximum safety for permitted applications.

Non-permitted usage

During assembly, ensure that improper loading does not arise due to any of the following factors:

- Direction of pull is obstructed
- Direction of pull is not within the indicated area
- Loading ring rests against edges or loads

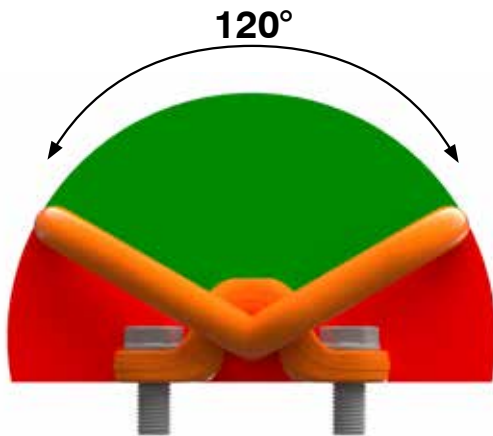

* Permissible load directions

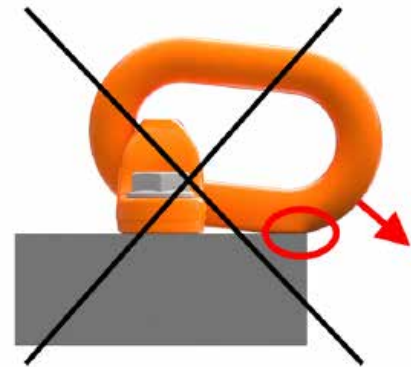

Image 1: front, Image 2: back

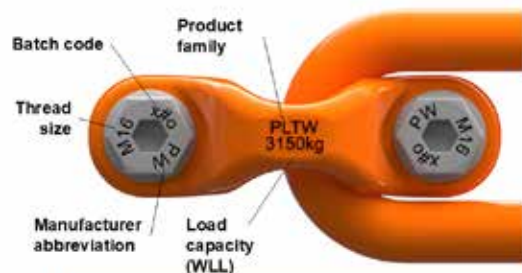
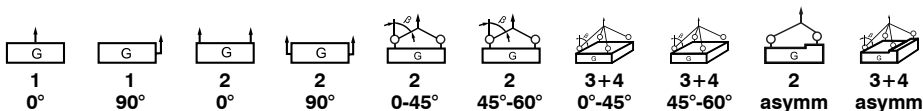

Image 3: Labelling on ringholder and screw

Method of lifting
Number of legs
Angle of inclination



| Code | Thread [mm] | Torque [Nm] | Working load limit (G) [kg] | | | | | | | | | |
|------------|-------------|-------------|-----------------------------|--------|--------|--------|--------|--------|--------|--------|--------|--------|
| | | | 3.150 | 3.150 | 6.300 | 6.300 | 4.450 | 3.150 | 6.680 | 4.720 | 3.150 | 3.150 |
| PLTW 3,15t | M16 | 150 | 3.150 | 3.150 | 6.300 | 6.300 | 4.450 | 3.150 | 6.680 | 4.720 | 3.150 | 3.150 |
| PLTW 4,5t | M20 | 250 | 4.500 | 4.500 | 9.000 | 9.000 | 6.360 | 4.500 | 9.540 | 6.750 | 4.500 | 4.500 |
| PLTW 10t | M30 | 400 | 10.000 | 10.000 | 20.000 | 20.000 | 14.100 | 10.000 | 21.200 | 15.000 | 10.000 | 10.000 |
| PLTW 16t | M36 | 700 | 16.000 | 16.000 | 32.000 | 32.000 | 22.620 | 16.000 | 33.900 | 24.000 | 16.000 | 16.000 |

Safety factor 4:1

| Code | Thread [mm] | Load capacity [kg] | a [mm] | c [mm] | d [mm] | e [mm] | g [mm] | k [mm] | l [mm] | n [mm] | Hexagon [mm] | Eye [mm] | Weight [kg/pc.] |
|------------|-------------|--------------------|--------|--------|--------|--------|--------|--------|--------|--------|--------------|----------|-----------------|
| PLTW 3,15t | M16 | 3.150 | 40 | 20 | 65 | 134 | 39 | 90 | 128 | 24 | 10 | 24 | 1,40 |
| PLTW 4,5t | M20 | 4.500 | 40 | 20 | 65 | 135 | 40 | 100 | 140 | 30 | 12 | 30 | 1,70 |
| PLTW 10t | M30 | 10.000 | 65 | 27 | 103 | 207 | 62 | 160 | 222 | 45 | 17 | 46 | 6,00 |
| PLTW 16t | M36 | 16.000 | 70 | 33 | 107 | 230 | 69 | 176 | 246 | 54 | 19 | 50 | 9,30 |

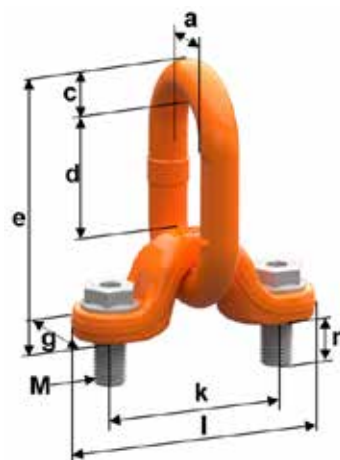

| Straight pull 0° | Lateral load direction permitted (ring is aligned) up to 60° | Lateral load direction not permitted (ring is not aligned) |
|---|---|---|
| | | |
| Nominal working load limit for loading along the screw axis (column „0°“ in the working load limit table) | Nominal working load limit for loading in an angle up to 60° to the screw axis (column „90°“ in the working load limit table) | Usage with nominal working load limit is possible. It is preferable to mount the lifting point in such a way that it is loaded in the folding direction (see figure in the middle). |

pewag RGS eyebolt



This high-strength RGS eyebolt is the ideal for lifting machine parts. Eyebolts may only be tightened manually and are not suitable for diagonal pull. However, they cannot be beaten when it comes to quality.

Permitted usage

For working load limits in the permitted directions of pull (fig. Permitted usage), please refer to the working load limit table on the following pages.

Non-permitted usage

During assembly, ensure that improper loading cannot arise due to any of the following factors:

- Direction of pull is obstructed
- Direction of pull is not within the indicated area (fig. Non-permitted usage)

Please note that the RGS eyebolt may only be placed under load in the direction of pull! For all other lashing types, use the rotatable PLGW eyebolt or the rotatable lifting points PLAW or PLDW.

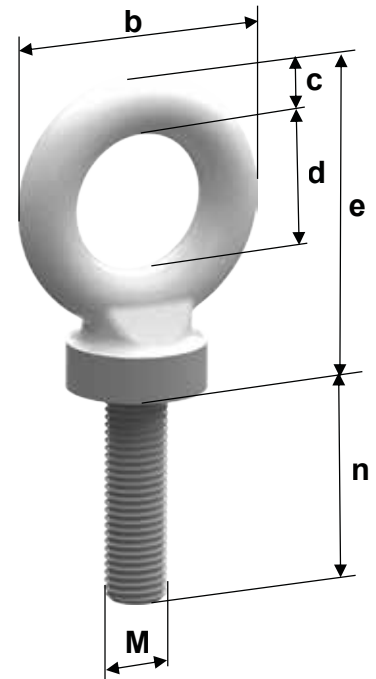

Permitted usage

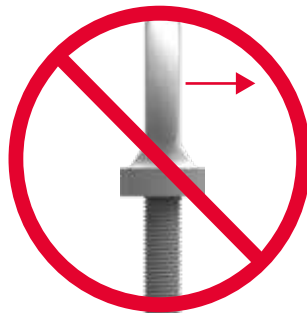

Non-permitted usage

| Code | Thread [mm] | Working load limit I-Strang 0° [kg] | Working load limit II-Strang 0° [kg] | b [mm] | c [mm] | d [mm] | e [mm] | n [mm] | Weight [kg/unit] |
|--------|-------------|-------------------------------------|--------------------------------------|--------|--------|--------|--------|--------|------------------|
| RGS 8 | M8 | 400 | 800 | 34 | 7 | 20 | 44 | 24 | 0,05 |
| RGS 10 | M10 | 700 | 1.400 | 38 | 8 | 22 | 49 | 30 | 0,10 |
| RGS 12 | M12 | 1.000 | 2.000 | 47 | 10 | 26 | 59 | 36 | 0,14 |
| RGS 14 | M14 | 1.200 | 2.400 | 57 | 14 | 29 | 71 | 40 | 0,25 |
| RGS 16 | M16 | 1.500 | 3.000 | 65 | 14 | 35 | 79 | 55 | 0,36 |
| RGS 20 | M20 | 2.500 | 5.000 | 73 | 16 | 39 | 89 | 59 | 0,55 |
| RGS 24 | M24 | 4.000 | 8.000 | 95 | 20 | 54 | 114 | 84 | 1,12 |
| RGS 30 | M30 | 6.000 | 12.000 | 108 | 24 | 59 | 132 | 100 | 1,84 |
| RGS 36 | M36 | 8.000 | 16.000 | 118 | 25 | 67 | 137 | 118 | 2,44 |
| RGS 42 | M42 | 10.000 | 20.000 | 139 | 31 | 79 | 166 | 135 | 4,00 |
| RGS 48 | M48 | 18.000 | 36.000 | 181 | 43 | 97 | 208 | 150 | 8,20 |

Safety factor 4:1

Additional sizes available upon request!

pewag – progressive, innovative and reliable

State-of-the-art technology for applications that carry some weight.

Our experience goes back centuries and makes pewag a company built on three principles: progression, innovation and reliability - in short, the factors that are reflected in every single one of our products.

pewag lifting points are products that stand out for their excellent compatibility with the globally successful pewag lifting chain programme and that make it even more versatile and flexible. Guaranteed ease-of-use when it comes to assembly and application is part of the pewag standard.

The weld-on lifting point PLEW complies with Machine Directive 2006/42/EC and is tested according to EN 1677-1 and BGR 500. Load capacities are clearly marked on the welding pad.

All welding operations comply with the provisions of DIN EN ISO 14341 and must be performed by welders with a valid qualification according to EN ISO 9606-1. The lifting points are delivered in individual packaging complete with user information and welding instructions.

Working load limits will vary according to the type of application, number of legs and angle of inclination and are listed in tables, which form an integral part of the detailed user manual corresponding to the Machine Safety Regulation 2010 and the Machine Directive. Each lifting point comes with a full operating manual.



PLEW marking



Operating manual



DGUV test certification

Easier Access to Your Certificates

Our Online Certificates Software enables customers to create and retrieve their inspection certificates and annual inspection reports anytime, anywhere.

This ensures quick and seamless access to important documents.

Key benefits:



✓ User-friendly interface



✓ 24/7 availability



✓ All certificates in one place



Online Certificates



for Your Needs

The service includes certificates for pro points as well as for other product groups from pewag.

pewag PLE/N eta



For welding onto machine components or vehicle bodies, special products are required that are ideal for attaching lifting and lashing devices. The PLE pewag pro points eta (grade 8) is such a product that has made a name for itself when it comes to high-strength eyebolts. An integrated spring keeps the ring in any position that is required. The product may be loaded in all directions.

Permitted usage

For working load limits in the permitted directions of pull (fig. Permitted usage), please refer to the working load limit table on the following pages.

Non-permitted usage

During assembly, ensure that improper loading does not arise due to any of the following factors:

- Direction of pull is obstructed
- Direction of pull is not within the indicated area
- Loading ring rests against edges or loads

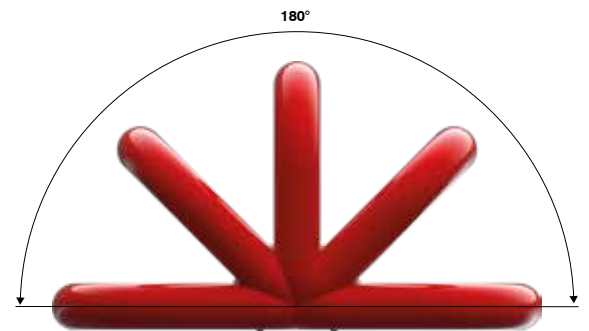

Permissible load directions



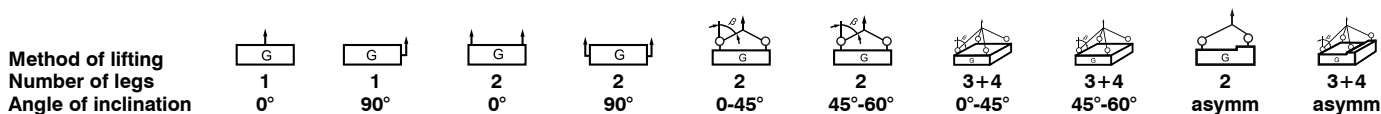

| Code | Working load limit (G) [kg] | | | | | | | | | |
|----------|-----------------------------|--------|--------|--------|--------|--------|--------|--------|--------|--------|
| | 1 | 1 | 2 | 2 | 2 | 2 | 3+4 | 3+4 | 2 | 3+4 |
| PLE/N 6 | 1.120 | 1.120 | 2.240 | 2.240 | 1.500 | 1.120 | 2.300 | 1.600 | 1.120 | 1.120 |
| PLE/N 8 | 2.000 | 2.000 | 4.000 | 4.000 | 2.800 | 2.000 | 4.200 | 3.000 | 2.000 | 2.000 |
| PLE/N 10 | 3.150 | 3.150 | 6.300 | 6.300 | 4.400 | 3.150 | 6.600 | 4.700 | 3.150 | 3.150 |
| PLE/N 13 | 5.300 | 5.300 | 10.600 | 10.600 | 7.400 | 5.300 | 11.200 | 7.900 | 5.300 | 5.300 |
| PLE/N 16 | 8.000 | 8.000 | 16.000 | 16.000 | 11.300 | 8.000 | 16.900 | 12.000 | 8.000 | 8.000 |
| PLE/N 22 | 15.000 | 15.000 | 30.000 | 30.000 | 21.000 | 15.000 | 31.800 | 22.500 | 15.000 | 15.000 |

| Code | WLL [kg] | a [mm] | b [mm] | c [mm] | d [mm] | e [mm] | g [mm] | h [mm] | l [mm] | Weight [kg/unit] |
|----------|----------|--------|--------|--------|--------|--------|--------|--------|--------|------------------|
| PLE/N 6 | 1.120 | 40 | 62 | 11 | 42 | 79 | 36 | 26 | 35 | 0,31 |
| PLE/N 8 | 2.000 | 42 | 69 | 13 | 45 | 86 | 37 | 28 | 37 | 0,40 |
| PLE/N 10 | 3.150 | 45 | 78 | 17 | 47 | 98 | 41 | 34 | 40 | 0,63 |
| PLE/N 13 | 5.300 | 55 | 99 | 22 | 53 | 119 | 61 | 44 | 50 | 1,46 |
| PLE/N 16 | 8.000 | 70 | 120 | 25 | 73 | 146 | 63 | 48 | 64 | 2,30 |
| PLE/N 22 | 15.000 | 97 | 163 | 33 | 92 | 195 | 89 | 70 | 90 | 5,40 |

Safety factor 4:1

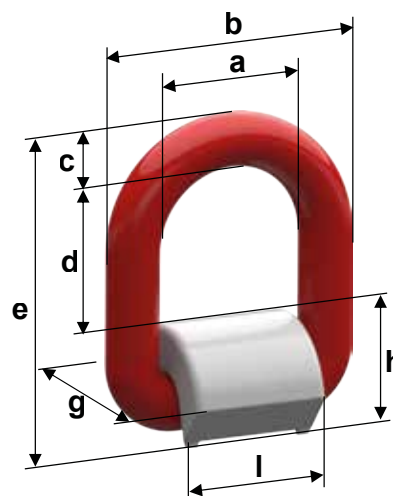

| Straight pull 0° | Lateral load direction „permitted“ (ring is aligned) 90° | Lateral load direction “permitted” (ring not aligned) |
|---|---|---|
| | | |
| Higher working load limit for loading vertically to welding level (column "0°" in the working load limit table) | Nominal working load limit for loading parallel to welding level (column "90°" in the working load limit table) | Usage with nominal working load limit is possible. It is preferable to weld on the ring in such a way that it is loaded in the folding direction. |

pewag PLEW eta



The high-strength pewag winner pro points eta lifting points for welding onto machine components or vehicle bodies are ideal for the hanging of lifting and lashing parts. Thanks to the integrated spring, the ring is kept in any position that is required.

The PLEW has a higher nominal working load limit than the pewag PLE/N and is also suitable for straight-pull applications (preferred direction of loading) with higher working load limits (see operating manual). Grooves on the welding pad at 45° and 60° make it easier to recognise the permitted angle of inclination.

Each lifting point comes with an individual serial number. Also available with peTAG upon request.

All welding operations comply with the provisions of DIN EN ISO 14341 and must be performed by welders with a valid qualification according to EN ISO 9606-1.

The lifting points are delivered in individual packaging complete with user information and welding instructions.

Permitted usage

Working load limit as stated in the test certificate and/or the working load limit table, in the specified directions of pull.

Non-permitted usage

When choosing your configuration, check that there is no risk of improper loading due to any of the following factors:

- Direction of pull is obstructed
- Direction of pull is not within the indicated area
- Loading ring rests against edges or surfaces

Optionally also available with peTAG (NFC chip) or PIP (colour marking).

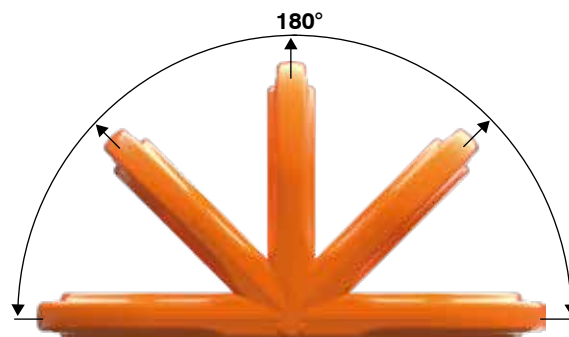

Permissible load directions

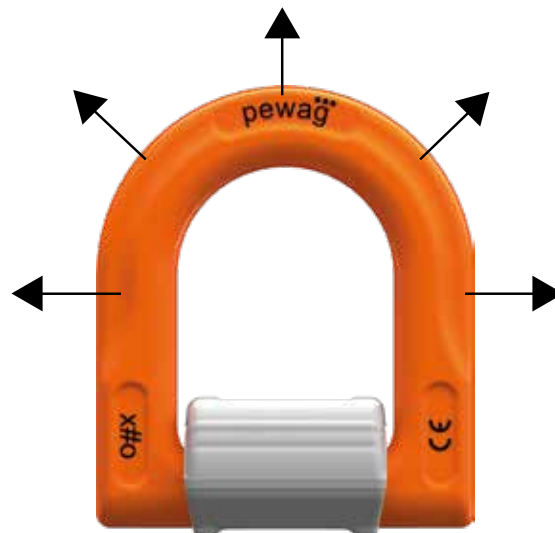

Permissible load directions



PLEW marking

| | | | | | | | | | | |
|----------------------|----|-----|----|-----|-------|---------|--------|---------|-------|-------|
| Method of lifting | | | | | | | | | | |
| Number of legs | 1 | 1 | 2 | 2 | 2 | 2 | 3+4 | 3+4 | 2 | 3+4 |
| Angle of inclination | 0° | 90° | 0° | 90° | 0-45° | 45°-60° | 0°-45° | 45°-60° | asymm | asymm |

| Code | Working load limit (G) [kg] | | | | | | | | | |
|-------------------------|-----------------------------|--------|--------|--------|--------|--------|--------|--------|--------|--------|
| | PLEW 1,5 t ^C | 2.500 | 1.500 | 5.000 | 3.000 | 2.100 | 1.500 | 3.100 | 2.200 | 1.500 |
| PLEW 2,5 t ^C | 4.000 | 2.500 | 8.000 | 5.000 | 3.500 | 2.500 | 5.300 | 3.700 | 2.500 | 2.500 |
| PLEW 4 t ^C | 6.000 | 4.000 | 12.000 | 8.000 | 5.600 | 4.000 | 8.400 | 6.000 | 4.000 | 4.000 |
| PLEW 6,7 t | 10.000 | 6.700 | 20.000 | 13.400 | 9.400 | 6.700 | 14.200 | 10.000 | 6.700 | 6.700 |
| PLEW 10 t | 15.000 | 10.000 | 30.000 | 20.000 | 14.100 | 10.000 | 21.200 | 15.000 | 10.000 | 10.000 |
| PLEW 19 t ¹⁾ | 25.000 | 19.000 | 50.000 | 38.000 | 26.800 | 19.000 | 40.300 | 28.500 | 19.000 | 19.000 |

| Code | WLL [kg] | a [mm] | b [mm] | c [mm] | d [mm] | e [mm] | g [mm] | h [mm] | l [mm] | Weight [kg/unit] |
|--------------------------|----------|--------|--------|--------|--------|--------|--------|--------|--------|------------------|
| PLEW 1,5 t ^{CR} | 1.500 | 38 | 65 | 14 | 40 | 79 | 32 | 25 | 35 | 0,32 |
| PLEW 2,5 t ^{CR} | 2.500 | 44 | 75 | 16 | 47 | 91 | 37 | 28 | 41 | 0,50 |
| PLEW 4 t ^{CR} | 4.000 | 48 | 84 | 18 | 51 | 101 | 43 | 32 | 45 | 0,75 |
| PLEW 6,7 t | 6.700 | 60 | 107 | 24 | 64 | 132 | 58 | 44 | 56 | 1,70 |
| PLEW 10 t | 10.000 | 66 | 126 | 27 | 69 | 150 | 69 | 54 | 61 | 2,80 |
| PLEW 19 t ¹⁾ | 19.000 | 95 | 171 | 38 | 100 | 206 | 92 | 68 | 89 | 6,50 |

¹⁾ Spring serves only as an aid during the welding process. With this type, the spring does not hold the in every position.

Safety factor 4:1

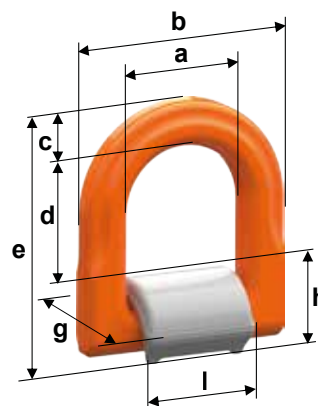
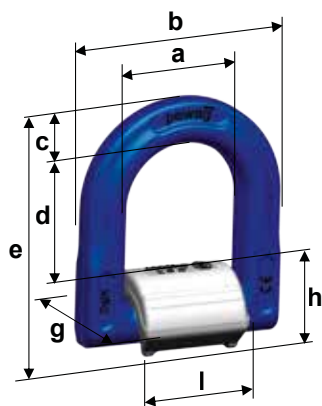

^{CR} = The PLEW is available in selected sizes as a CRYO variant (PLEW CR - ring blue powder-coated) and can be ordered for operating temperatures down to -40 °C.

| Straight pull 0° | Lateral load direction „permitted“ (ring is aligned) 90° | Lateral load direction permitted (Ring not aligned) |
|---|---|---|
| | | |
| Higher working load limit for loading vertically to welding level (column "0°" in the working load limit table) | Nominal working load limit for loading parallel to welding level (column "90°" in the working load limit table) | Usage with nominal working load limit is possible. It is preferable to weld on the ring in such a way that it is loaded in the folding direction. |

pewag PLEW-LC



upon request

The pewag PLEW-LC serves as a lashing point for welding onto loads or load carriers, in which elements of lashing chains (hooks, shackles, ...) for lashing a load can be attached. The product can be used for direct lashing and lashing down. The maximum permissible lashing force LC is indicated at the lashing point. It features an integrated spring that holds the ring securely in place, making it easier to attach the lashing chain.

The robust bracket is engineered to handle full loads in every direction, ensuring maximum versatility and safety. Each lashing point is marked with a unique serial number for traceability.

Designed for tough conditions, it remains fully operational at temperatures as low as -20 °C. Additionally, the product meets high safety standards with a safety factor of 2:1, ensuring reliable performance under demanding loads.

Permitted usage

For working load limits in the permitted directions of pull, please refer to the working load limit table.

Non-permitted usage

During assembly, ensure that improper loading does not arise due to any of the following factors:

- Direction of pull is obstructed
- Direction of pull is not within the indicated area
- Loading ring rests against edges or surfaces

Optionally also available with peTAG (NFC chip) or PIP (colour marking).



Identification on weld on block

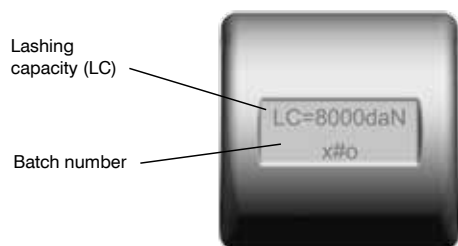

Component description and location of identification details on product.

| Code | Max. lashing capacity LC [daN] | a [mm] | b [mm] | c [mm] | d [mm] | e [mm] | g [mm] | h [mm] | l [mm] | Weight [kg/unit] |
|---------------|--------------------------------|--------|--------|--------|--------|--------|--------|--------|--------|------------------|
| PLEW-LC 3000 | 3000 | 38 | 65 | 14 | 40 | 79 | 32 | 25 | 35 | 0,32 |
| PLEW-LC 5000 | 5000 | 44 | 75 | 16 | 47 | 92 | 37 | 28 | 41 | 0,50 |
| PLEW-LC 8000 | 8000 | 48 | 84 | 18 | 51 | 101 | 43 | 32 | 45 | 0,75 |
| PLEW-LC 13400 | 13400 | 60 | 107 | 24 | 64 | 132 | 58 | 44 | 56 | 1,70 |
| PLEW-LC 20000 | 20000 | 66 | 126 | 27 | 69 | 150 | 69 | 54 | 61 | 2,80 |

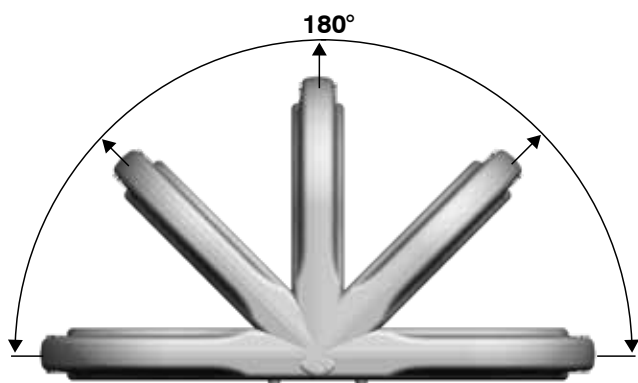
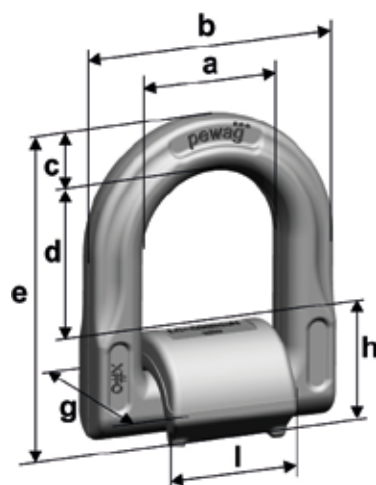

Permissible load directions

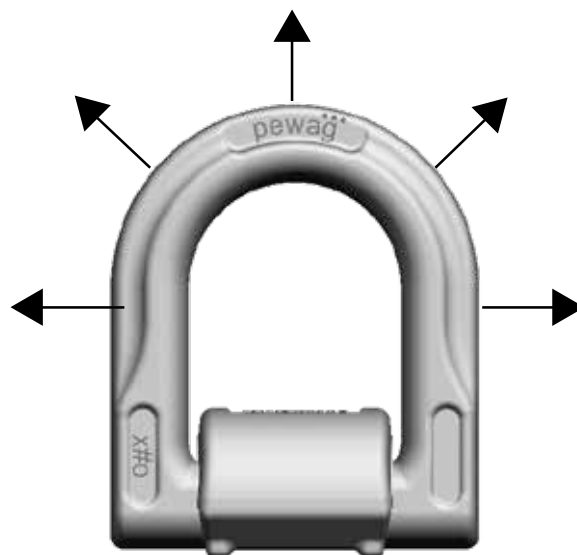

Permissible load directions

pewag Ro-Ro



upon
request

The Ro-Ro is a lashing point from the pewag profilash family, specifically developed for securing commercial vehicles and semi-trailers on Ro-Ro ships in accordance with EN 29367 Part 1 and Part 2. It features a ring that can be folded 180° and a weld-on block. With a lashing capacity (LC) of 10.000 daN, the Ro-Ro ensures reliable and robust securing of cargo.

Additional benefits of the Ro-Ro lifting point:

- Large ring opening according to standard specifications (min. 80mm)
- Operating temperature -40°C without reduction - Serial number possible
- 2-fold safety against breakage



| Code | Lashing capacity [daN] | a [mm] | b [mm] | c [mm] | d [mm] | e [mm] | g [mm] | h [mm] | l [mm] | Weight [kg/pc.] |
|-----------------|------------------------|--------|--------|--------|--------|--------|--------|--------|--------|-----------------|
| Ro-Ro 10.000daN | 10000 | 89 | 141 | 25 | 89 | 169 | 69 | 54 | 61 | 2,9 |

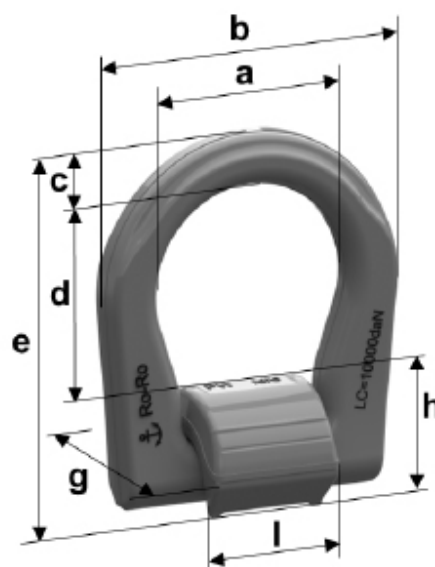

pewag PLKW kappa



The weldable lifting point, featuring two patented welding blocks, is ideal for lifting and load securing. It is primarily used on machine frames, steel structures, beams, and housings. No measuring of the welder is necessary because of the patented design. This design offers a safety feature, as the required overlap is ensured. peTAG available upon request only.



Technical Data



pewag AWHW



This high-strength hook is particularly well suited for welding onto excavator bucket, spreader beams etc. Its outstanding features include a die-forged, tempered safety catch, making it extra-robust. As the safety catch locks into the tip of the hook, it provides excellent protection against lateral shifting.

The product is manufactured according to EN 1677-1 with a higher working load limit and comes with full operating and welding instructions that must be complied with at all times. The weld-on hook also has a CE marking. Replacing the SFGW-A safety catch set is easy and quick, without the need for special tools.



| Code | WLL [kg] | L [mm] | H [mm] | G [mm] | B [mm] | C [mm] | Weight [kg/unit] |
|----------|----------|--------|--------|--------|--------|--------|------------------|
| AWHW 1,3 | 1.300 | 95 | 74 | 20 | 25 | 34 | 0,67 |
| AWHW 3,8 | 3.800 | 132 | 106 | 26 | 35 | 40 | 1,40 |
| AWHW 6,3 | 6.300 | 167 | 133 | 29 | 45 | 49 | 2,95 |
| AWHW 10 | 10.000 | 175 | 136 | 29 | 50 | 49 | 4,02 |

Safety factor 4:1

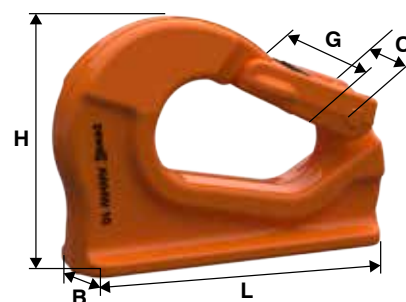

pewag PLGW-PSA anchorage point

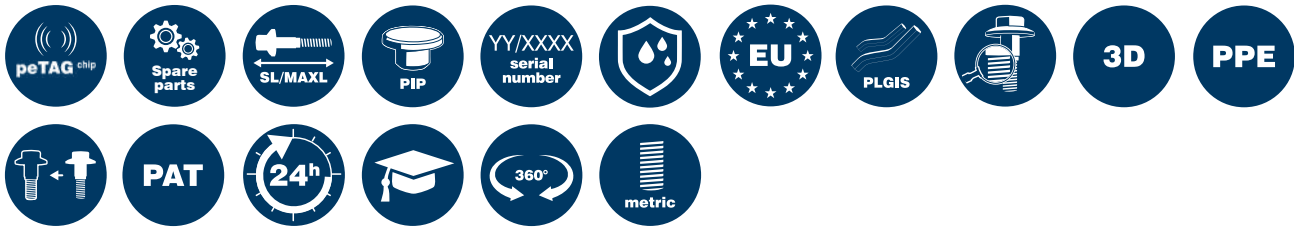

The pewag PLGW-PSA anchorage point is part of the anchorage system to which personal fall protection equipment may be attached. It was developed and tested in accordance with the stringent safety requirements for personal protection equipment according to EU regulation 2016/425 and already complies with the new EN795:2012 and CEN/TS 16415 standards. Usage is also possible in accordance with OSHA standards (1910/1926). For all other details, please refer to the operating manual.

The PLGW-PSA is available in a “Basic” and “Supreme” version: The PLGW-PSA Basic is intended for permanent attachment to the anchorage system (e.g. tripod) and is mounted using a commercial Allen key. The PLGW-PSA Supreme is based on a patented system that allows for tool-free assembly and disassembly. The anchorage point is therefore easy to remove after usage. For detailed information on functionalities, please refer to the operating manual.

Thanks to the varnish in RAL 1003, both versions are also permitted for usage on stationary antennae systems (radio masts). The pewag PLGW-PSA anchorage point is available in size M12 (for 1 person), M16 and M20 (for max. 2 persons). All sizes are also available with a customised thread length.

Each anchorage point is marked with the thread size and the permissible number of persons as well as additional information. The individual serial number enables complete documentation of the required test procedures.

Optionally also available with peTAG (NFC chip) or PIP (colour marking).



pewag PLGW-PSA supreme for tool-free assembly



PLGW-PSA rotatable



PLGW-PSA dis-/assembly

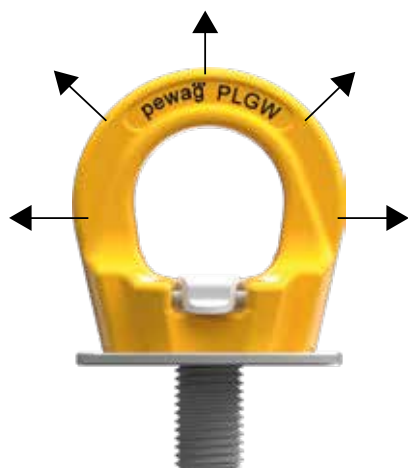

Loadable on all sides



Marking on sleeve and screw

| Code | Thread [mm] | Persons | a [mm] | b [mm] | c [mm] | d [mm] | e [mm] | f [mm] | n [mm] | n max [mm] | Hexagon [mm] | Weight [kg/unit] |
|--------------|-------------|---------|--------|--------|--------|--------|--------|--------|--------|------------|--------------|------------------|
| PLGW PSA M12 | M12 | 1 | 30 | 55 | 12 | 32 | 63 | 55 | 20 | 160 | 8 | 0,30 |
| PLGW PSA M16 | M16 | 2 | 35 | 64 | 14 | 36 | 70 | 62 | 25 | 160 | 10 | 0,47 |
| PLGW PSA M20 | M20 | 2 | 40 | 73 | 16 | 41 | 81 | 66 | 30 | 160 | 12 | 0,60 |



pewag PLGW-PSA basic



pewag PLGW-PSA basic

pewag PLGWI-PSA anchorage point



The pewag PLGWI-PSA anchorage point is part of the anchorage system to which personal fall protection equipment may be attached. It was developed and tested in accordance with the stringent safety requirements for personal protection equipment according to EU regulation 2016/425 and already complies with the new EN795:2012 and CEN/TS 16415 standards. Usage is also possible in accordance with OSHA standards (1910/1926). For all other details, please refer to the operating manual.

Unlike the PLGW-PSA, the PLGWI-PSA is made from stainless material (INOX).

In addition, the screws are available in the desired and/or maximum lengths. The PLGWI-PSA may be mounted using a special pewag PLGW key or a standard Allen key.

Optionally also available with peTAG (NFC chip) or PIP (colour marking).



pewag PLGWI-PSA





Loadable on all sides



Marking on sleeve and screw.

| Code | Thread [mm] | Persons | a [mm] | b [mm] | c [mm] | d [mm] | e [mm] | f [mm] | n [mm] | n max [mm] | Hexagon [mm] | Weight [kg/unit] |
|---------------|-------------|---------|--------|--------|--------|--------|--------|--------|--------|------------|--------------|------------------|
| PLGWI PSA M12 | M12 | 1 | 30 | 55 | 12 | 30 | 59 | 40 | 18 | 160 | 8 | 0,23 |
| PLGWI PSA M16 | M16 | 2 | 35 | 64 | 14 | 35 | 67 | 45 | 23 | 160 | 10 | 0,37 |



pewag PLGWI-PSA

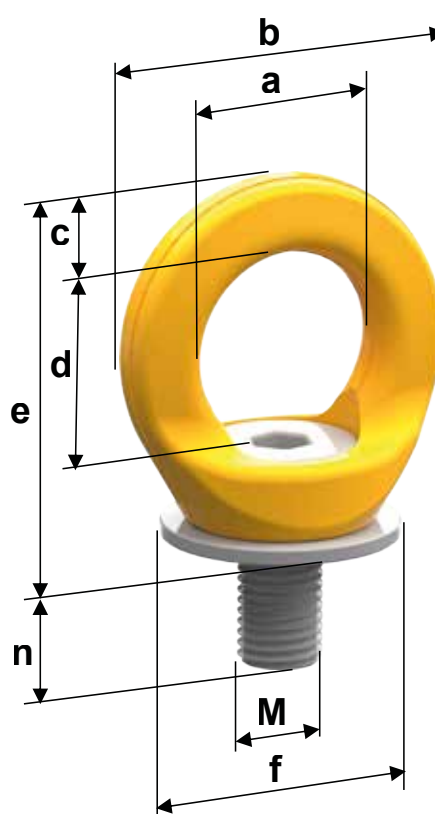

pewag PLGWI-PSA

pewag pro points

As individual as your needs.

Innovative. Reliable. Industry-specific.

pewag offers tailored solutions for diverse industries, ensuring quality and safety in every application. From durable chains to advanced lifting solutions, we deliver the tools you need to succeed.

Discover the right solution for your challenges – with pewag.



AGRICULTURE &
FORESTRY
INDUSTRY



AQUACULTURE,
FISHERIES &
MARINE INDUSTRY



CONSTRUCTION
INDUSTRY



DEFENSE &
SECURITY



ENTERTAINMENT
INDUSTRY



ENGINEERING &
MANUFACTURING
INDUSTRY



MATERIALS
HANDLING
INDUSTRY



MINING
INDUSTRY



MOULDING
INDUSTRY



OIL & GAS
INDUSTRY



PUBLIC
ADMINISTRATION
INDUSTRY



TRANSPORT
& LOGISTICS
INDUSTRY



VEHICLE &
ROAD TRAFFIC
INDUSTRY



WASTE WATER
INDUSTRY



WIND ENERGY
INDUSTRY

Based on your requirements, pewag develops safe and user-friendly, customised solutions.

- Whether there is a thread that needs adjusting (pipe thread, internal thread, locking pin etc.),
- solutions need to be customised (colour, reduced contact surface etc.)
- or welded adaptations are required (welded hook, attachment to mounting plate etc.)

we are looking forward to supporting you all the way.

Just get in touch!

propoints@pewag.com



pewag PLMS screw nut

This set is often used for pewag winner lifting points with customised lengths.

For sizes M8 to M48, these accessories are available as a set: The nut manufactured according to DIN 980V in strength category 10. A washer completes the set.

From size M56, the nut is 1,5 times as long and is manufactured according to DIN 6331.

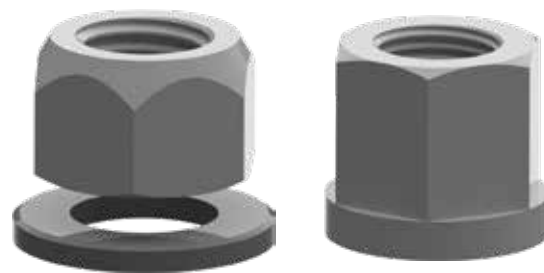

PLMS: M8 to M48

M56 and larger

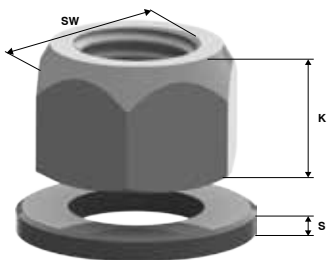
| PLMS Screw nut | Code | Thread [mm] | Thread pitch P [mm] | SW [mm] | K [mm] | S [mm] | PU [unit] |
|--|---------|-------------|---------------------|---------|--------|--------|-----------|
|  | PLMS 8 | M8 | 1,25 | 13 | 8 | 1,60 | 10 |
| | PLMS 10 | M10 | 1,50 | 17 | 10 | 2 | 10 |
| | PLMS 12 | M12 | 1,75 | 19 | 12 | 2,50 | 10 |
| | PLMS 14 | M14 | 2 | 22 | 14 | 3 | 10 |
| | PLMS 16 | M16 | 2 | 24 | 16 | 3 | 10 |
| | PLMS 18 | M18 | 2,50 | 27 | 18 | 4 | 10 |
| | PLMS 20 | M20 | 2,50 | 30 | 20 | 4 | 10 |
| | PLMS 24 | M24 | 3 | 36 | 24 | 4 | 10 |
| | PLMS 30 | M30 | 3,50 | 46 | 30 | 5 | 4 |
| | PLMS 36 | M36 | 4 | 55 | 36 | 6 | 1 |
| | PLMS 42 | M42 | 4,50 | 65 | 42 | 7 | 1 |
| | PLMS 48 | M48 | 5 | 75 | 48 | 8 | 1 |
| | PLMS 56 | M56 | 5,50 | 85 | 84 | - | 1 |
| | PLMS 64 | M64 | 6 | 95 | 96 | - | 1 |
| PLMS 72 | M72 | 6 | 105 | 108 | - | 1 | |
| PLMS 80 | M80 | 6 | 115 | 120 | - | 1 | |
| PLMS 90 | M90 | 6 | 130 | 135 | - | 1 | |
| PLMS 100 | M100 | 6 | 145 | 150 | - | 1 | |

pewag PLGES spare latches set

The spare latches set for the PLGW pewag pro points gamma supreme is available now.

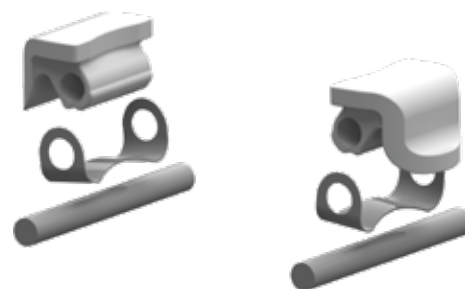

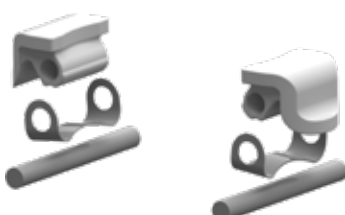
| PLGES Spare latches | Code | Accessory part for | PU [pair] |
|---|-------------|--|-----------|
|  | PLGES 0,5 t | PLGW 0,3 t; PLGW 0,5 t; PLGW U 3/8 | 1 |
| | PLGES 0,7 t | PLGW 0,7 t; PLGW U 1/2 | 1 |
| | PLGES 1,5 t | PLGW 1,5 t; PLGW U 5/8, PLOW 2 t | 1 |
| | PLGES 2,3 t | PLGW 2,3 t; PLGW U 3/4 | 1 |
| | PLGES 3,2 t | PLGW 3,2 t; PLGW U 1 | 1 |
| | PLGES 4 t | PLGW 4 t; PLGW 4,9 t; PLGW U 1 1/4, PLOW 3,4 t, PLOW 4,7 t | 1 |
| | PLGES 7 t | PLGW 7 t; PLGW U 1 1/2 | 1 |
| | PLGES 9 t | PLGW 9 t; PLGW U 1 3/4 | 1 |
| | PLGES 12 t | PLGW 12 t | 1 |

pewag Replacement screws for PLAW, PLGW and PLZW

pewag spare parts meet high quality standards. The PLAS, PLGS, and PLZS screws are compatible with the PLAW, PLGW, and PLZW pro points types, offering reliable performance with metric threads.



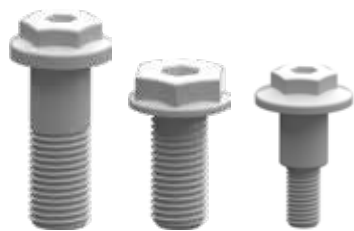

| Replacement screws for PLAW, PLGW and PLZW | Thread [mm] | PU [pieces] | Code for PLAW | Code for PLGW | Code for PLZW |
|--|-------------|-------------|---------------|---------------|---------------|
|  PLAS PLGS PLZS | M8 | 10 | PLAS 0,3 t | PLGS 0,3 t | PLZS 0,4 t |
| | M10 | 10 | PLAS 0,63 t | PLGS 0,5 t | PLZS 0,63 t |
| | M12 | 10 | PLAS 1 t | PLGS 0,7 t | PLZS 0,95 t |
| | M14 | 10 | - | - | PLZS 1,3 t |
| | M16 | 10 | PLAS 1,5 t | PLGS 1,5 t | PLZS 1,8 t |
| | M18 | 10 | - | - | PLZS 2,2 t |
| | M20 | 10 | PLAS 2,5 t | PLGS 2,3 t | PLZS 2,5 t |
| | M22 | 10 | - | - | PLZS 3,7 t |
| | M24 | 10 | PLAS 4 t | PLGS 3,2 t | PLZS 4 t |
| | M27 | 4 | - | - | PLZS 5,4 t |
| | M30 | 4 | PLAS 6 t | PLGS 4,9 t | PLZS 6,3 t |
| | M33 | 2 | - | - | PLZS 8 t |
| | M36 | 1 | PLAS 8 t | PLGS 7 t | PLZS 10 t |
| | M42 | 1 | PLAS 10 t | PLGS 9 t | PLZS 13 t |
| | (M42) | 1 | PLAS 15 t | - | - |
| | M48 | 1 | PLAS 20 t | PLGS 12 t | PLZS 15 t |

pewag SFGW-A safety catch sets

These SFGW-A safety catch sets forged-with and electro-galvanised safety catch and a spring made from rust-proof spring steel are all about safety and security.

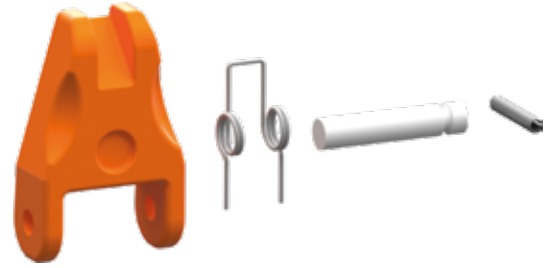
The safety catch sets are in a league of their own - even the tiniest pewag parts offer outstanding quality!



| SFGW-A safety catch sets Code | Code | For accessory part |
|---|----------|--------------------|
|  | SFGW-A 1 | AWHW 1,3 |
| | SFGW-A 3 | AWHW 3,8 |
| | SFGW-A 6 | AWHW 6,3, AWHW 10 |

pewag PLGIS Allen key set

Assembly of the PLGW requires tools. Special Allen keys make assembly of the PLGW basic M8 up to and including M20 particularly straightforward. The keys are marked with the size and the torque and are available as a complete set.

The PLGW supreme is designed for tool-free assembly.



pewag ALP thread adapter

Loads often come with tapped holes for DIN-580 eyebolts.

The thread adapter can be mounted using a commercial open-jawed spanner; the pewag lifting point is then mounted according to the instruction manual.

By using the pewag thread adapter, the high-strength pewag lifting points (PLAW, PLGW, PLDW) can replace the standard eyebolts.

The thread adapter can be mounted using a commercial open-jawed spanner; the pewag lifting point is then mounted according to the instruction manual. The permitted working load limit corresponds to the pewag lifting point fitted in the internal thread.



pewag peTAG chip

The pewag peTAG solution enables the intelligent, location-independent management of product-specific information.

Via an NFC chip on the product, relevant product information (working load limits, safety instructions, operating manual) is literally at your fingertips. All you need is a NFC-compatible smartphone.

Your benefits at a glance:

- Clear object identification.
- Efficient documentation of test processes.
- Safe archiving of data.
- Mobile data retrieval without expensive readers.
- Automated compilation and dispatch of inspection reports.
- Efficient interaction with service partners.
- Intelligent, high-performance online platform.

Note: As every lifting point comes with just one pilot hole, you can use them either for the peTAG (NFC chip) or the PIP (colour marking).



Example: PLGW with peTAG (NF chip)



peTAG solution:
Smart solution
– intelligent core

pewag PIP colour marking

The PIP is a variable marking made from soft plastic that fits into the existing 4mm peTAG hole on all screw-in pewag winner lifting points.

The plug is a visual indicator for regular inspections – if no peTAG was fitted into the hole, the PIP may be fitted instead, serving as a test marking.

It is characteristic of the PIP that it is available in a different colour each year. The user (and tester) is thus able to determine the date of the latest inspection based on the colour of the PIP.

Note: As every lifting point comes with just one pilot hole, you can use them either for the peTAG (NFC chip) or the PIP (colour marking).



User information

Information and safety guidelines on usage, storage, inspection and servicing of pewag winner lifting points.

General information

pewag winner pro points lifting points are quality products that are suitable for a wide range of general lifting purposes using different designs, types of load and application modes. For detailed information on design types and the classification of working load limits, please refer to the tables in this catalogue

Responsibility is key

If the pewag winner pro points lifting points are used correctly and by competent persons, they have a long lifespan and provide the highest possible safety standards. Material and personal damage can be avoided by reading this user information carefully and handling all lifting processes in a responsible, provident manner.

Please note that all operating manuals that come with the product must be complied with at all times!

Changes to the condition as delivered

Only the original parts provided in the delivery may be used to complete the installation.

Modifying the original condition by grinding, welding (with the exception of the weldable lifting points), drilling, stamping etc. is not permitted and means exposing yourself and others to unnecessary danger. In such a case, safety can no longer be guaranteed and usage becomes dangerous. pewag does not accept any liability in such cases. Do not apply any surface coatings, i.e. do not subject them to hot galvanizing or electrogalvanizing. Cleaning processes that rely on dipping or removing a coating with chemicals are potentially dangerous processes that may give rise to hazards.

We recommend consulting pewag prior to performing these processes. The welding seam of the weldable lifting points are best protected against corrosion by applying a varnish.

Correct usage of the lifting points

If used correctly, pewag winner pro points lifting points are safe and strong. Please note that they may only be used by authorised personnel who have received sufficient training. Correct usage is subject to the following principles: The position on the load must be chosen in such a way that the transmitted forces of the base material can be absorbed without any deformations. Prior to loading, the load bracket needs to be adjusted in the direction of pull. Non-permissible

strains such as twisting or rotating the load must be avoided. Please ensure that the lifting gear can be mounted and demounted without any risk of injury! Damages to the load, lifting gear or lifting can be avoided by proper positioning. In cases where a single lifting point is used, this has to be mounted flat over the centre of gravity of the load. When using two lifting points (2-leg chain sling), these have to be mounted symmetrically on both sides of the centre of gravity of the load. When using 3 or 4 lifting points (3 or 4-leg chain slings), these have to be mounted evenly on one level surrounding the centre of gravity of the load. Care must be taken to ensure that the load is evenly spread among the individual chain legs.

The load capacities of the pewag lifting points only apply if the load is symmetrically distributed over the individual lifting points. If the load is lifted, the same angles of inclination result in the individual slings.

For our pewag lifting points a load may be considered symmetrical when all of the following conditions apply:

1. The load is less than 80 % of the indicated load capacity
2. The angles of inclination of all chain legs are not lower than 15° and are very similar.
3. For three- and four-leg lifting, it must be ensured that the corresponding plan angles are within 15° of each other. Usage in acids and caustic solutions or exposure to their vapours is not permitted.

Please be aware of this requirement at all times as certain production processes release acids and/or vapours! The working load limit will also be reduced if the lifting points are exposed to higher temperatures. Please comply with the supplied operating instructions at all times. For further information, please contact the pewag technical service team.

Screw-in lifting points

We recommend the following minimum screw penetration:

- 1 x M for steel (M = thread size, for instance M16)
- 1,25 x M for cast steel
- 2 x M for aluminium

To ensure safe usage, the thread size and thread length for materials of lower strength, like light metals, non-ferrous metals or cast iron, must be chosen in such a way that the occurring loads may be absorbed by the lifting point.

Impact loading or vibration may cause the screw to become loose. To avoid this, apply a liquid threadlock such as Loctite. If using additional tools of this sort, please follow the manufacturer's instructions. pewag accepts no liability if components are used that are not part of the pewag range (e.g. screws).

Please check the following points prior to each usage:

- Screws are sufficiently tightened and the fastening torque corresponds to that specified in the operating manual
- The lifting point is complete, i.e. no components are missing
- The stamp of the lifting point is clearly legible
- The lifting point shows no signs of damage such as notches, cracks, deformations, wear, strong corrosion, surface cracks on load-bearing parts, noticeable signs of excessive heat exposure (such as burnt varnish, discolouration of the base material)
- Rotatable lifting points may be rotated freely and smoothly.

In addition, check before each assembly:

- Screws and threads are not damaged
- Correct screw size, screw grade and screw depth

The supplied operating manual must be complied with at all times!

If in doubt or in case of visible damage, the lifting points must be decommissioned and inspected by a competent person. This also applies to usage after unusual events, for instance uncontrolled exposure to heat.

Weldable lifting points

For welding, the following instructions apply:

- Welding processes may only be performed by a qualified welder according to EN ISO 9606-1.
- The material of the welded-on parts is specified on the operating manual that is included in the scope of delivery.
- The surface of the welding area must be thoroughly cleaned before welding. Rust and scale, paint, oil or similar must be removed.
- Contact between the coated bracket and the welded material must be avoided

Please check the following points prior to each usage:

- The stamp of the lifting point is clearly legible
- The lifting point shows no signs of damage such as notches, cracks, deformations, wear, strong corrosion, surface cracks on load-bearing parts, noticeable signs of excessive heat exposure on the coated bracket (such as burnt varnish, discolouration of the base material)
- No surface cracks or damage along the welding seam

The supplied operating manual must be complied with at all times!

If in doubt or in case of visible damage, the lifting points must be decommissioned and inspected by a competent person. This also applies to usage after unusual events, for instance uncontrolled exposure to heat.

Correct maintenance

The maintenance of pewag winner pro points lifting points must be performed by competent persons. Improper use or use by unauthorised persons must be avoided at all times.

Prevention is better than cure!!

Prior to using a lifting point, it must be verified whether the lifting point was inspected every 12 months by a competent person and in accordance with applicable national standards. If the chain sling is frequently used at its full working load limit, more frequent inspections are required! All inspections must be documented, in particular with regard to results and servicing activities. These records must be kept throughout the service life of the lifting points.

A sample documentation sheet is available for download at www.pewag.com.

Clean storage

pewag winner pro points lifting points must always be stored in a clean and dry conditions and protected against corrosion, i.e. slightly lubricated.

The thread shafts must be protected from damage using appropriate means.

Important

Some pro points lifting points may also be used for lashing - see the user manual. The admissible lashing capacity is double the nominal working load limit, as a 2-fold safety factor applies to the securing of loads. For the PLZW lifting points, a 2,5-fold safety factor applies as lifting operations require a safety factor of 5:1 for lifting operations. We recommend consulting the pewag technical service prior to using the lifting points as lashing points.

Example

PLE/N 8 = 2.000 kg working load limit for lifting operations. As lashing point LC = 4.000 daN admissible lashing capacity

Warning: A lifting point may only be used **either** for lifting, **or** for lashing. If a lifting point was once used for lashing, it must not be used for lifting!

Please refer to our website at www.pewag.com for detailed information on working load limits, measures and 3D models (section Lifting Technology / Lifting Points). Each lifting point comes with a detailed operating manual in two languages.

Detailed original operating manuals for all our pewag quality products are available for download at www.pewag.com. Our manuals are subject to a continuous improvement process to ensure that they are always up to date. For this reason, always refer to the latest version of a manual.

VAN SOEST

Morsestraat 17
4004 JP Tiel

0344-610607
info@vansoest-bv.nl

www.vansoest-bv.nl

